

# 11301

## Programmable Oscilloscope

### Service Reference Manual

#### WARNING

The following servicing instructions are for use by qualified personnel only. To avoid personal injury, do not perform any servicing unless you are qualified to do so. Refer to the Safety Summary prior to performing any service.

*Please check for CHANGE INFORMATION at the rear of this manual.*

## **INSTRUMENT SERIAL NUMBERS**

Each instrument has a serial number on a panel insert, tag, or stamped on the chassis. The first number or letter designates the country of manufacture. The last five digits of the serial number are assigned sequentially and are unique to each instrument. Those manufactured in the United States have six unique digits. The country of manufacture is identified as follows:

<b>B000000</b>	Tektronix, Inc. Beaverton, Oregon, USA
<b>100000</b>	Tektronix Guernsey, Ltd., Channel islands
<b>200000</b>	Tektronix United Kingdom, Ltd., London
<b>300000</b>	Sony/Tektronix, Japan
<b>700000</b>	Tektronix Holland, NV, Heerenveen, The Netherlands

Copyright © Tektronix, Inc., 1988. All rights reserved. Tektronix products are covered by U.S. and foreign patents, issued and pending. TEKTRONIX, TEK., SCOPEMOBILE and  are registered trademarks.

MS-DOS® is a registered trademark of Microsoft Corporation.  
Printed in U.S.A.

# Contents

---

List of Illustrations .....	vii
List of Tables .....	ix
Safety Summary .....	x

## Section 1—General Information

Introduction .....	1-1
Operating Power Information .....	1-1
Power Cord Information .....	1-2
Operating Voltage .....	1-2
Memory Backup Power .....	1-4
Operating Environment .....	1-4
Operating Temperature .....	1-4
Ventilation Requirements .....	1-4
Instrument Options .....	1-4
List of Options .....	1-5
Option 1C .....	1-5
Option 1R .....	1-5
Option 1T .....	1-5
Option A1 .....	1-5
Option A2 .....	1-5
Option A3 .....	1-5
Option A4 .....	1-5
Option A5 .....	1-5

## Section 2—Checks and Adjustments

Installing and Removing Plug-In Units .....	2-1
Minimize the Time Power is Off .....	2-2
Test Equipment .....	2-2
RS-232 Cable Requirements .....	2-2
Using the CATS Software .....	2-5
Creating a Working Disk For a Dual-Floppy Drive System .....	2-5
Installing CATS Software on a Hard Disk System .....	2-5
Running the CATS Software .....	2-6
Selecting Menu Items: Default Selection is Highlighted .....	2-6
Exiting from CATS and Other F1 Key Options .....	2-7
Storing and Reloading Mainframe Calibration Constants .....	2-7
Test Data Logging .....	2-8
CATS SRQ Messages .....	2-9
CATS Error Messages .....	2-9
Using this Procedure .....	2-10
Format Conventions .....	2-10
Terms Used .....	2-10
Mainframe Menu Selection and Measurement Techniques .....	2-10
Abbreviated Sequence for Performance Verification .....	2-11

Mainframe Preparation .....	2-12
Part 1 – Power Supply .....	2-14
Examine Supply Voltages .....	2-14
Adjust +5.2 V Reference .....	2-17
Adjust Regulator Reference .....	2-19
Part 2 – Extended Diagnostics .....	2-21
Part 3 – Touch Screen .....	2-22
Touch Screen Sensitivity Adjustment .....	2-24
Part 4 – CVR Accuracy .....	2-27
Part 5 – A/D Converter .....	2-29
Part 6 – ACVS Gain .....	2-31
Part 7 – Front Panel Display Adjustments .....	2-34
Part 8 – Display Quality .....	2-35
Grid Bias .....	2-36
Y-Axis Alignment .....	2-39
Display Clarity and Geometry .....	2-40
High Drive Focus .....	2-44
Part 9 – Stored Waveform Vectors .....	2-45
Part 10 – Spot Shift .....	2-48
Spot Shift Adjustment .....	2-50
Part 11 – Readout Jitter .....	2-52
Vertical Readout Jitter .....	2-52
Horizontal Readout Jitter .....	2-54
Part 12 – Vertical Center .....	2-56
Part 13 – Magnified Registration .....	2-58
Part 14 – XY Phase .....	2-60
Part 15 – Plug-in Interface Gains .....	2-63
Vertical Gain .....	2-63
Horizontal XY Gain .....	2-64
Part 16 – Vertical Center (Second Pass) .....	2-65
Part 17 – Sweep Slew Rate Selfcal .....	2-67
Part 18 – Sweep Gains .....	2-68
Part 19 – Beam Registration .....	2-70
Part 20 – Cursor to Graticule Match .....	2-72
Part 21 – Reference Oscillator .....	2-73
Part 22 – Front Panel Calibrator .....	2-77
Front Panel CALIBRATOR Output Adjustment .....	2-79
Part 23 – Intensity Settings .....	2-80
Part 24 – Install Instrument Covers .....	2-82
Part 25 – Sweep Timing Accuracy .....	2-83
High Speed Linearity Adjustment .....	2-85
5 ns Timing Adjustment .....	2-89
Main Sweep 1 ns Timing Adjustment .....	2-90
Delayed Sweep 1 ns Timing Adjustment .....	2-91
Delayed Sweep 500 ps Timing Adjustment .....	2-92
Part 26 – Delta Delay Accuracy .....	2-93
Part 27 – Probe Skew Range .....	2-94

Part 28 – Vertical High Frequency Response .....	2-95
Vertical High Frequency Gain .....	2-96
Vertical Step Response .....	2-98
Counter View Step Response .....	2-100
Vertical Amplifier Adjustment .....	2-102
Counter View Step Response Adjustment .....	2-108
Part 29 – Vertical/Measurement Accuracy .....	2-110
Part 30 – Trigger Filters .....	2-112
Part 31 – Trigger Noise and Sensitivity .....	2-114
Part 32 – Trigger Sensitivity .....	2-115
Trigger Sensitivity Adjustment: Main .....	2-117
Trigger Sensitivity Adjustment: Delayed .....	2-118
Part 33 – Trigger Accuracy .....	2-119
Internal Trigger Accuracy .....	2-119
External Trigger Accuracy .....	2-120
External Counter Timer Trigger Accuracy .....	2-121
Part 34 – Line Trigger .....	2-122
Part 35 – Center Compartment X-Axis Accuracy .....	2-123
Part 36 – Rear Panel Input/Output Signals .....	2-125
Part 37 – Counter Reference Clock In/Out .....	2-128
Part 38 – Frequency Accuracy .....	2-130
Part 39 – External A and B Input Sensitivity .....	2-131
Part 40 – 2 ns Holdoff .....	2-132
Part 41 – Holdoff By Events .....	2-133
Part 42 – Time Interval Using Sweeps .....	2-134
Part 43 – Minimum Time Interval .....	2-135
Part 44 – Store Cal Constants .....	2-136
Part 45 – Reset DIP Switches and Set Time/Date .....	2-137

### Section 3 – Maintenance

Preventive Maintenance .....	3-1
Cabinet Panel Removal .....	3-1
Cleaning .....	3-1
Exterior .....	3-2
Crt .....	3-2
Interior .....	3-2
Visual Inspection .....	3-3
Periodic Electrical Adjustment .....	3-3
Corrective Maintenance .....	3-4
Power Supply Voltage Hazard .....	3-4
Ordering Parts .....	3-4
Static-Sensitive Device Classification .....	3-5
Removing and Replacing FRUs .....	3-7
Electrical Lock-on of the STANDBY/ON Power Switch .....	3-10
Power Supply Module Removal .....	3-11
Fan Motor Removal .....	3-14
Cathode-Ray Tube Removal .....	3-15
Cathode-Ray Tube Replacement .....	3-18

Lithium Battery Disposal and First Aid .....	3-20
Removal and Handling .....	3-20
Storage .....	3-20
Board Cleaning .....	3-20
Disposal .....	3-21
Replacement .....	3-21
Emergency & First Aid Information .....	3-21
Front Panel Assembly Removal .....	3-22
Circuit Board Removal .....	3-23
A1 Plug-In Interface Board .....	3-23
A4 Regulator Board .....	3-28
A7 Touch Panel Board .....	3-30
A10 Front Panel Interface Board .....	3-34
A11 Main Processor Board .....	3-35
A12 Vertical Amp Board .....	3-38
A13 Scope Logic Board .....	3-41
A14 Time Base Board .....	3-45
A15 Counter/Timer Reference Board .....	3-47
Rear Panel Plate Removal .....	3-49
R80 Crt Termination Network .....	3-51
FRU IC Replacement .....	3-52
“Slam-Pack” Integrated Circuits .....	3-52
Firmware Integrated Circuits (“Dual In-Line Package” ICs) .....	3-54
Preliminary Verification Procedure .....	3-54
Firmware Upgrade Procedure .....	3-54
Cables and Connectors .....	3-56
Restoring Factory Calibration .....	3-56
Interconnecting Pins .....	3-58
Coaxial-type End Lead Connectors (Peltolas) .....	3-58
Multi-Pin Connectors .....	3-58
Implosion Shield Removal .....	3-60
FRU Fuses .....	3-61
Line Fuse .....	3-61
Circuit Board Fuse .....	3-61
Checks After FRU Replacement .....	3-62
Crt .....	3-62
Crt Termination Network .....	3-64
A1 Plug-In Interface Board .....	3-65
A7 Touch Panel Board .....	3-66
A10 Front Panel Interface Board .....	3-66
A11 Main Processor Board .....	3-67
Establishing a Set of Calibration Constants .....	3-67
Method 1 .....	3-67
Method 2 .....	3-68
Method 3 .....	3-69
Method 4 .....	3-69
Readjustment .....	3-69
A12 Vertical Amp Board .....	3-71
A13 Scope Logic Board .....	3-72
A14 Time Base Board .....	3-74
A15 Counter/Timer Reference Board .....	3-75

<b>Troubleshooting</b> .....	3-76
<b>Diagnostics Overview</b> .....	3-76
Level 0: Kernel Diagnostics .....	3-76
Level 1: Self-Test Diagnostics .....	3-76
Kernel Verification .....	3-77
Power-Up Mode .....	3-77
Normal (Non-Power-Up) Mode .....	3-77
Instrument Verification .....	3-77
Power-Up Mode .....	3-77
Normal (Non-Power-Up) Mode .....	3-77
Level 2: Extended Tests Diagnostics .....	3-79
Index Code Conventions .....	3-79
Front Panel .....	3-79
Test Menu Examples .....	3-80
Test Menu Area .....	3-80
Block and Area Menus .....	3-81
Routine Menus .....	3-81
Analog and Digital Test Menus .....	3-82
Mainframe Digital Test Menu .....	3-82
Memory Test Menu .....	3-83
Test Status Area .....	3-83
GPIB/RS-232-C .....	3-84
System Mode (GPIB & RS-232-C) .....	3-85
Test Commands .....	3-85
Diagnostic Terminal Mode (RS-232-C) .....	3-86
Terminal Interface .....	3-86
Invocation Command .....	3-86
Terminal Diagnostic Commands .....	3-86
New Configuration Calibration .....	3-87
Restoring Calibration Data from EEROM .....	3-87
Procedure .....	3-87
Field Replaceable Unit (FRU) Guide .....	3-88
Abbreviations of FRU Names .....	3-88
Abbreviations of Component and Module Names .....	3-88
Extended Diagnostic Error Index Codes .....	3-89
Enhanced Accuracy Mode Troubleshooting .....	3-90
Other Troubleshooting .....	3-94
Crt .....	3-94
Module Troubleshooting .....	3-94
No Display .....	3-94
Display With No Intensity Control .....	3-97
Intermittent Display .....	3-97
Crt Termination .....	3-98
Module Troubleshooting .....	3-98
Power Supply Assembly .....	3-100
Module Troubleshooting .....	3-100
Regulator Board .....	3-100
Fuse Troubleshooting .....	3-101

**Section 4 – Theory of Operation**

Block Diagram Description .....	4-1
A1 Plug-in Amplifier Interface Board .....	4-1
A5, A8, and A9 Front Panel Assembly .....	4-1
A7 Touch Panel Board .....	4-1
A10 Front Panel Interface Board .....	4-3
A11 Main Processor Board .....	4-3
A12 Vertical Amp Board .....	4-4
A13 Scope Logic Board .....	4-5
A14 Time Base Board .....	4-5
A15 Counter Timer Reference Board (available in Option 1T only) .....	4-5

**Section 5 – Replaceable Parts**

**Change Information**

**Related Documentation**

The Parts List at the rear of this manual lists the Tektronix part numbers for all Standard Accessories provided with this product.

**Manuals (Standard Accessories)**

- Introduction to the 11301 and 11302 Programmable Oscilloscopes
- 11301 and 11302 Programmable Oscilloscopes User's Reference Manual
- 11301 and 11302 Programmable Oscilloscopes Pocket Reference
- 11301 and 11302 Incoming Inspection Procedure
- Option 1R Rackmounting Instructions



# List of Illustrations

---

Figure 2-1	Location of DIP Switch on the A11 Main Processor board	2-12
Figure 2-2	Location of the J90 connector on the A11 Main Processor board	2-15
Figure 2-3	Location of J63-2, the +5.1 V test point on the A2 Power Supply	2-16
Figure 2-4	A2A2 Control Rectifier board test point and adjustment locations	2-18
Figure 2-5	A4 Regulator board test point and adjustment locations	2-20
Figure 2-6	Locations of crt touch areas to test	2-23
Figure 2-7	A10 Front Panel Interface board (Touch Screen) test point and adjustment locations	2-24
Figure 2-8	Waveform display showing Touch Screen adjustment waveforms	2-25
Figure 2-9	A13 Scope Logic board (CVR Accuracy) test point and adjustment locations	2-28
Figure 2-10	A11 Main Processor board (A/D Converter) adjustment locations	2-30
Figure 2-11	A14 Timebase board (ACVS Gain) test point locations	2-32
Figure 2-12	A13 Scope Logic board (ACVS Gain) adjustment location	2-33
Figure 2-13	A13 Scope Logic board (Display Quality) adjustment locations	2-38
Figure 2-14	Trace separation measurement (0.2 div or less) on the displayed XY waveform	2-46
Figure 2-15	A11 Main Processor board (Stored Waveform Vectors) adjustment locations	2-47
Figure 2-16	A12 Vertical board and A14 Timebase board (Spot Shift) test point and adjustment locations	2-51
Figure 2-17	A12 Vertical board (Vertical Readout Jitter) adjustment location	2-53
Figure 2-18	A14 Timebase board (Horizontal Readout Jitter) adjustment location	2-55
Figure 2-19	A12 Vertical board (Vertical Center) adjustment and shorting locations	2-57
Figure 2-20	A14 Timebase board (Magnified Registration) adjustment location	2-59
Figure 2-21	An XY waveform display showing dimensions A, B, and C. The actual phase difference is equal to $\sin^{-1}(A \div B)$ .	2-61
Figure 2-22	A14 Timebase board (XY Phase) adjustment location.	2-62
Figure 2-23	A12 Vertical board adjustment and shorting locations.	2-66
Figure 2-24	CRT display showing the trace to graticule measurements for Beam Registration.	2-71
Figure 2-25	CRT display showing an acceptable grat_prep waveform.	2-71
Figure 2-26	A14 Timebase board (Reference Oscillator) adjustment location.	2-74
Figure 2-27	Location of the Option 1T Oven Oscillator Adjustment.	2-76
Figure 2-28	A10 Front Panel Interface board (Calibrator) test point locations.	2-79
Figure 2-29	Waveform alignment for the Linearity measurement (dimension A should be the same at both ends).	2-87
Figure 2-30	A14 Timebase board (High Speed Linearity) adjustment location.	2-88
Figure 2-31	A12 Vertical board (High Frequency Response) adjustment locations.	2-105
Figure 3-1	Field Replaceable Units (FRU) Locator.	3-8
Figure 3-2	Rear panel location of screws securing the Power Supply Module.	3-12
Figure 3-3	Bottom view of the A2A2 Control Rectifier board showing connector locations.	3-13
Figure 3-4	Rear view of crt base-pin socket and inside view of rear panel.	3-16
Figure 3-5	Plug-in compartment showing mounting screws for the A1 Plug-In Interface board.	3-24
Figure 3-6	Connector and screw locations for the removal of the A4 Regulator board.	3-28
Figure 3-7	The diagonal method to remove (and to reinstall) the retaining screws on the 11301 crt scale cover.	3-30
Figure 3-8	Connector locations for the removal of the A7 Touch Panel board (inside view).	3-31
Figure 3-9	Connector locations for removal of the A10 Front Panel Interface board.	3-34
Figure 3-10	Connector locations for removal of the A11 Main Processor board.	3-35

Figure 3-11	Removal of left side decorative trim covers. ....	3-38
Figure 3-12	Connector locations for removal of the A12 Vertical Amp board. ....	3-39
Figure 3-13	Connector locations for removal of the A13 Scope Logic board. ....	3-41
Figure 3-14	Connector locations for removal of the A14 Time Base board. ....	3-45
Figure 3-15	Connector locations for removal of the A15 Counter/Timer Reference board (option 1T). ....	3-47
Figure 3-16	Location of rear panel plate mounting screws. ....	3-49
Figure 3-17	IC lead indexing diagram. ....	3-53
Figure 3-18	IC insertion-extraction pliers. ....	3-55
Figure 3-19	11301 Cabling Diagram. ....	3-57
Figure 3-20	Orientation of multi-pin connectors. ....	3-59
Figure 3-21	Block menu sample display. ....	3-80
Figure 3-22	Area menu sample display. ....	3-80
Figure 3-23	Block and Area display fields. ....	3-81
Figure 3-24	Display of Analog Test Menu. ....	3-82
Figure 3-25	Display of a Plug-in Digital Test Menu (plug-in diagnostics only). ....	3-82
Figure 3-26	Display of Mainframe Digital Test Menu. ....	3-82
Figure 3-27	Display of Memory Test Menu. ....	3-83
Figure 3-28	Test Status areas of the display. ....	3-83
Figure 3-29	Enhanced Accuracy adjustment procedure. ....	3-92
Figure 3-30	A13 Scope Logic board test point, resistor, and fuse locations. ....	3-96
Figure 3-31	Crt Termination. ....	3-99
Figure 3-32	Rear panel principal line fuse location. ....	3-101
Figure 4-1	11301 System Block Diagram. ....	4-2

# List of Tables

---

Table 1-1	Power-Cord Conductor Identification .....	1-2
Table 1-2	Power-Cord and Plug Identification .....	1-3
Table 1-3	Option Information Locator .....	1-6
Table 2-1	Test Equipment .....	2-3
Table 2-2	Crosshatch Display .....	2-42
Table 2-3	Sinewave Display .....	2-42
Table 2-4	Character Display .....	2-43
Table 2-5	Sinewave Display .....	2-43
Table 2-6	Adjustment Tests to Correct Main and Delayed Sweep Failures .....	2-84
Table 2-7	11301 Vertical Gain .....	2-95
Table 2-8	Vertical Adjustments Required for Check Failures .....	2-102
Table 2-9	Initial Adjustments for Critical Components .....	2-107
Table 2-10	Vertical Cursor Tolerances .....	2-111
Table 2-11	Measurement Tolerances .....	2-111
Table 2-12	Horizontal Tolerances .....	2-124
Table 3-1	Relative Susceptibility to Damage From Static Discharge .....	3-5
Table 3-2	Power-up Kernel Failure Codes .....	3-78
Table 3-3	Extended (Ext) Tests Diagnostics Error Index Codes .....	3-89
Table 3-4	Enhanced Accuracy Adjustment Process .....	3-90
Table 3-5	Enhanced Accuracy Mode Error Messages and Troubleshooting .....	3-93

# Safety Summary

---

The general safety information in this part of the summary is for both operating and servicing personnel. Specific warnings and cautions will be found throughout the manual where they apply, but may not appear in this summary.

## Terms

### In This Manual

CAUTION statements identify conditions or practices that could result in damage to the equipment or other property.

WARNING statements identify conditions or practices that could result in personal injury or loss of life.

### As Marked on Equipment

CAUTION indicates personal injury hazard not immediately accessible as one reads the marking, or a hazard to property including the equipment itself.

DANGER indicates a personal injury hazard immediately accessible as one reads the marking.

## Symbols

### In This Manual



Static-Sensitive Devices.



This symbol indicates where applicable cautionary or other information is to be found.

### As Marked on Equipment



DANGER – High Voltage.



Protective ground (earth) terminal.



ATTENTION – refer to manual.

## Warnings

### **Power Source**

This product is intended to operate from a power source that will not apply more than 250 V rms between the supply conductors or between either supply conductor and ground. A protective ground connection, by way of the grounding conductor in the power cord, is essential for safe operation.

### **Grounding the Product**

This product is grounded through the grounding conductor of the mainframe power cord. To avoid electric shock, plug the power cord into a properly wired receptacle before connecting to the product input or output terminals. A protective-ground connection, by way of the grounding conductor in the power cord, is essential for safe operation.

### **Danger Arising from Loss of Ground**

Upon loss of the protective-ground connection, all accessible conductive parts (including knobs and controls that may appear to be insulating), can render an electric shock.

### **Do Not Operate in Explosive Atmospheres**

To avoid explosion, do not operate this product in an atmosphere of explosive gasses.

### **Do Not Service Alone**

Do not perform internal service or adjustment of this product unless another person capable of rendering first aid and resuscitation is present.

### **Use Care When Servicing with Power On**

Dangerous voltages exist at several points in this product. To avoid personal injury, do not touch exposed connections and components while power is on.

Disconnect power before removing protective panels, soldering, or replacing components.

### **Crt Handling**

Use care when handling a crt. Breakage of the crt causes a high-velocity scattering of glass fragments (implosion). Protective clothing and safety glasses should be worn. Avoid striking the crt on any object which might cause it to crack or implode. When storing a crt, place it in a protective carton or set it face down in a protected location on a smooth surface with a soft mat under the faceplate.

### **Use the Proper Fuse**

To avoid fire hazard, use only the fuse specified in the parts list for your product, and which is identical in type, voltage rating, and current rating.



# Section 1

## General Information

---

This section gives all the information needed to apply power to the 11301 Programmable Oscilloscope.

Information on operating voltage and power cord needs, as well as environmental conditions such as operating temperature and ventilation requirements, is included here.

### Introduction

The 11301 Service Reference manual is designed for use by qualified service personnel. It contains information necessary to check, troubleshoot, and maintain the 11301 mainframe. Troubleshooting is primarily based upon internal diagnostics. These diagnostics isolate problems to the FRU (Field Replaceable Unit) level. Defective FRUs not detected by diagnostics are isolated using other means. Once the faulty FRU is identified, use the instructions provided in this manual to remove and replace it. The removal and immediate replacement of the faulty FRU allows a minimum of downtime for the user. Section 5, Replaceable Parts, gives a complete list of the FRUs in this instrument.

### Operating Power Information

This instrument can be operated from either a 115 V or 230 V nominal supply source, 48 to 440 Hz. The 6 ampere, 250 V line fuse is used for both 115 V and 230 V operation.

#### **WARNING**

*AC POWER SOURCE AND CONNECTION. The oscilloscope operates from a single-phase power source. It has a three-wire power cord and two-pole, three-terminal grounding-type plug. The voltage to ground (earth) from either pole of the power source must not exceed the maximum rated operating voltage, 250 volts.*

*Before making connection to the power source, check that the oscilloscope LINE VOLTAGE SELECTOR on the rear of the instrument is set to match the voltage of the power source, and has a suitable two-pole, three-terminal grounding-type plug.*

*GROUNDING. This instrument is safety Class 1 equipment (IEC designation). All accessible conductive parts are directly connected through the grounding conductor of the power cord to the grounded (earthing) contact of the power plug.*

**WARNING**

*The power input plug must be inserted only in a mating receptacle with a grounding contact where earth ground has been verified by a qualified service person. Do not defeat the grounding connection. Any interruption of the grounding connection can create an electric shock hazard.*

*For electric shock protection, the grounding connection must be made before making connection to the instrument's input or output terminals.*

**Power Cord Information**

A power cord with appropriate plug configuration is supplied with each instrument. Table 1-1 gives the color-coding of the conductors in the power cord. If you require a power cord other than the one supplied, refer to Table 1-2, Power-Cord and Plug Identification.

**TABLE 1-1  
Power-Cord Conductor Identification**



<b>Conductor</b>	<b>Color</b>	<b>Alternate Color</b>
Ungrounded (Line)	Brown	Black
Grounded (Neutral)	Light Blue	White
Grounded (Earthing)	Green/Yellow	Green

**Operating Voltage**

The LINE VOLTAGE SELECTOR (located on the rear panel) allows you to select 115 V or 230 V nominal line-voltage operation. The same line fuse is used for both 115 V and 230 V operation.

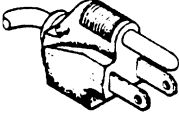
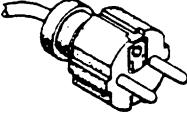

**TABLE 1-2  
Power-Cord and Plug Identification**

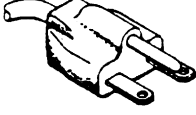
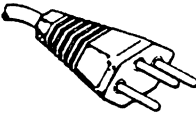
Plug Configuration	Usage (Max Rating)	Reference Standards & Certification	Option #
	North American 125 V/6 A	<sup>1</sup> ANSI C73.11 <sup>2</sup> NEMA 5-15-P <sup>3</sup> IEC 83 <sup>10</sup> UL <sup>11</sup> CSA	Standard
	European 220 V/6 A	<sup>4</sup> CEE (7),II, IV, VII <sup>3</sup> IEC 83 <sup>8</sup> VDE <sup>9</sup> SEMKO	A1
	United Kingdom 240 V/6 A	<sup>5</sup> BSI 1363 <sup>3</sup> IEC 83	A2
	Australian 240 V/6 A	<sup>6</sup> AS C112 <sup>12</sup> ETSA	A3
	North American 250 V/10 A	<sup>1</sup> ANSI C73.20 <sup>2</sup> NEMA 6-15-P <sup>3</sup> IEC 83 <sup>10</sup> UL <sup>11</sup> CSA	A4
	Switzerland 240 V/6 A	<sup>7</sup> SEV	A5

<sup>1</sup>ANSI – American National Standards Institute

<sup>2</sup>NEMA – National Electrical Manufacturer's Association

<sup>3</sup>IEC – International Electrotechnical Commission

<sup>4</sup>CEE – International Commission on Rules for the Approval of Electrical Equipment

<sup>5</sup>BSI – British Standards Institute

<sup>6</sup>AS – Standards Association of Australia

<sup>7</sup>SEV – Schweizerischer Elektrotechnischer Verein

<sup>8</sup>VDE – Verband Deutscher Elektrotechniker

<sup>9</sup>SEMKO – Swedish Institute for Testing and Approval of Electrical Equipment

<sup>10</sup>UL – Underwriters Laboratories

<sup>11</sup>CSA – Canadian Standards Association

<sup>12</sup>ETSA – Electricity Trust of South Australia

## Memory Backup Power

A battery within the instrument allows the retention of volatile memory upon loss of the ac power source. The battery provides memory backup power which stores the instrument settings when the power is off. The self-test will display a message to indicate when the battery needs to be replaced.

The battery has a nominal shelf life of approximately five years. Partial or total loss of stored settings upon power-up may indicate that the battery needs to be replaced.

## Operating Environment

The following environmental requirements are provided to ensure proper operation and long instrument life.

### Operating Temperature

This instrument can be operated where the ambient air temperature is between 0° and +50° C and can be stored in ambient temperatures from -40° to +75° C. After storage at temperatures outside the operating limits, allow the chassis to reach the safe operating temperature before applying power.

### Ventilation Requirements

To prevent damage to the Programmable Oscilloscope from overheated components, adequate internal airflow must be maintained at all times. Before turning on the power, check the air-intake holes for obstructions. Remove any obstructions to air flow and provide both the bench and the rack mount models with a minimum of two inches of clearance at the sides and rear. To maintain adequate cooling, a variable speed fan controls the air flow as temperature varies.



*If air flow is restricted, the instrument's power supply may temporarily shut down.*

## Instrument Options

Your instrument may be equipped with one or more instrument options. A brief description of each available option is given in the following discussion. Option information is incorporated into the appropriate sections of the manual. Refer to Table 1-3 and the Table of Contents for location of option information. For further information and prices of instrument options, see your Tektronix Products catalog or contact your Tektronix Field Office.

## List of Options

- Option 1C**                      Option 1C adds four bnc connectors to the front and rear panels so that signals may be internally routed directly between the two panels. This is especially useful for rackmounted applications. This option can be added at any time.
- Option 1R**                      Option 1R adds slide rails and rackmounting hardware to convert the benchtop instrument to a standard 19-inch rackmount version. This option can be added at any time.
- Option 1T**                      Option 1T provides a high-stability timebase for the Counter Timer. This option can be added at any time.
- Option A1**                      Replaces the standard power cord with the Universal European 220 V type power cord.
- Option A2**                      Replaces the standard power cord with the United Kingdom 240 V type power cord.
- Option A3**                      Replaces the standard power cord with the Australian 240 V type power cord.
- Option A4**                      Replaces the standard power cord with the North American 250 V type power cord.
- Option A5**                      Replaces the standard power cord with the Switzerland 240 V type power cord.

**TABLE 1-3  
Option Information Locator**

Option	Location in Manual		Information
	Section	Heading	
Option 1C (Provides back to front connectors)	1 General Information	List of Options	Gives brief description of Option 1C.
Option 1R (Provides rackmount hardware)	1 General Information	List of Options	Gives brief description of Option 1R.
Option 1T	1 General Information	List of Options	Gives brief description of Option 1T.
Option A1 (Provides Universal European power cord)	1 General Information	Table 1-2, Power-Cord and Plug Identification	Gives plug configurations ratings and referenced standards.
		List of Options	Gives brief description of Option A1.
Option A2 (Provides United Kingdom power cord)	1 General Information	Table 1-2, Power-Cord and Plug Identification	Gives plug configurations ratings and referenced standards.
		List of Options	Gives brief description of Option A2.
Option A3 (Provides Australian power cord)	1 General Information	Table 1-2, Power-Cord and Plug Identification	Gives plug configurations ratings and referenced standards.
		List of Options	Gives brief description of Option A3.
Option A4 (Provides North American power cord)	1 General Information	Table 1-2, Power-Cord and Plug Identification	Gives plug configurations ratings and referenced standards.
		List of Options	Gives brief description of Option A4.
Option A5 (Provides Switzerland power cord)	1 General Information	Table 1-2, Power-Cord and Plug Identification	Gives plug configurations ratings and referenced standards.
		List of Options	Gives brief description of Option A5.

# Section 2

## Checks and Adjustments

---

This section contains procedures to check electrical specifications, verify most instrument functions, and set all internal adjustments. This procedure provides a logical sequence of check and adjustment steps, and is intended to return the instrument to specified operation following repair, or as a part of a routine maintenance program. The procedure is semi-automated relying on computer aided test system (CATS) software running on an IBM compatible personal computer (PC) to control the mainframe. The Checks and Adjustment procedure contains manual and automated tests. The written procedure directs you to run CATS tests when necessary. The CATS software displays the tests in alphabetical order, not in the order in which they will be run. The PC controls the mainframe under test via the COM1 RS-232 port.

Consult the User's Reference manual for more information about advertised specifications and instrument operation. Consult the test equipment manuals for information concerning test equipment setup or interconnection. The specifications are given at the beginning of each procedure that verifies a performance specification.

### NOTE

*Performance specifications are used in the check portions of this procedure while tighter adjustment specifications are used in the adjustment portions to ensure that the advertised instrument performance is met in all normal operating conditions.*

## Installing and Removing Plug-In Units



*To avoid instrument damage, set the mainframe ON/STANDBY switch to STANDBY before installing or removing plug-in units.*

## Minimize the Time Power is Off

During the procedure you will be asked to change plug-in units and install or remove the top and bottom covers. Both of these tasks require a power-down with the ON/STANDBY switch. You should try to keep the power-off time to a minimum in order to reduce the internal temperature change. The mainframe accuracy is adversely affected by internal changes in temperature. In normal operation, Enhanced Accuracy is available only after a 20 minute warmup period. This requirement is defeated during the procedure to accelerate the execution time, but care should be taken to minimize the power-off time.

When moving plug-in units, a quick transfer (i.e., about 15 seconds) and power-up will essentially preserve the internal temperature and the Enhanced Accuracy state. Disconnect any cables or probes before beginning a plug-in unit move. An excessive delay in powering-up (beyond 30 seconds) will mean a warm-up period is necessary.

## Test Equipment

Table 2-1 contains suggested test equipment for use with the Checks and Adjustment Procedure. Procedure steps are based on the test equipment examples given, but other equipment with similar specifications may be substituted. However, using other equipment could alter the test results, the setup information, or the related connectors and adapters required.

### RS-232 Cable Requirements

The RS-232 cable that connects the PC COM1 port with the 11301 mainframe under test should be a standard controller-to-modem (DCE-DTE) type cable. The type of RS-232 connector your PC has will determine the type of connectors your cable must have. The two most common connectors are the 25 pin D type and the 9 pin D type. The 25 pin to 25 pin cable should at least have pins 2-2, 3-3, 4-4, 5-5, 7-7, 8-8, and 20-20 connected. The 9 pin to 25 pin RS-232 cable should be wired as follows:

9-Pin Connector	25-Pin Connector
1 (DCD)	8 (DCD)
2 (RD)	2 (RD)
3 (TD)	3 (TD)
4 (DTR)	6 (DSR)
5 (Sig GND)	7 (Sig GND)
6 (DSR)	20 (DTR)
7 (RTS)	5 (CTS)
8 (CTS)	4 (RTS)
9 (N.C.)	22 (RI)

**TABLE 2-1  
Test Equipment**

Description	Minimum Specification	Examples of Applicable Test Equipment
Portable computer (PC)	IBM PC compatible, 2 floppy drives, RS-232, 640 kbytes memory, MSDOS 2.1 or newer.	Compaq.
RS-232-C Cable	Standard DTE-DCE 25 pin - 25 pin D type or 25 pin - 9 pin D type	Tektronix Part 012-0911-00 (25-25 pin)
5 <sup>1</sup> / <sub>4</sub> " diskette (2 required)	Double sided, double density.	Maxell MD2-DD.
Digital Multimeter (DMM)	5 <sup>1</sup> / <sub>2</sub> digit, 0.01% dc acc, 0.1% resistance.	Fluke 8842A.
RF Synthesizer	50 kHz - 500 MHz, 1 part in 10 <sup>7</sup> accuracy, 700 mV rms.	Fluke 6061A.
Plug-In Amplifier	11000-Series, 150 MHz bw, 50 Ω & 1 MΩ impedance.	11A32, 11A33, 11A34.
Time Mark Generator	1 ns through 5 s markers in a 1-2-5 sequence, at least 5 parts in 10 <sup>7</sup> accuracy.	TEKTRONIX TG 501 Time Mark Generator with a TM 500-series Power Module.
Calibration Generator	Square wave output, 0.25% accuracy, 1-2-5 amplitude selection from 200 μV p-p to 100 V p-p, ~1 ms period.	TEKTRONIX PG 506 Calibration Generator with a TM 500-series Power Module.
Precision Time Base, Traceable Frequency Standard	1 MHz or 10 MHz out, 5 parts in 10 <sup>7</sup> accuracy; with mainframe Opt 1T, 5 parts in 10 <sup>8</sup> .	Efratom PTB-100 with Tektronix TM 500 Power Module or comparable WWV system.
Low Frequency Generator	1 Hz sinewave output, 4 V <sub>p-p</sub> .	TEKTRONIX FG503 Function Generator.
Signal Standardizer (2 required)	Tektronix Calibration Fixture modified for 11000-series mainframes (Service Kit 040-1212-00).	Tektronix Part 067-0587-02 or 067-0587-10.
Test Oscilloscope	50 MHz or greater bandwidth, 1 MΩ input impedance.	TEKTRONIX 2225 Oscilloscope or SC 504 Oscilloscope.
Oscilloscope Probes (2 required)	10X probes, compatible with the test scope.	TEKTRONIX P6103.

**TABLE 2-1 (cont)  
Test Equipment**

<b>Description</b>	<b>Minimum Specification</b>	<b>Examples of Applicable Test Equipment</b>
Low-pass filter		Tektronix Part 067-1320-00.
2X Attenuator (2 required)	14 dB attenuation, 50 $\Omega$ one male and one female BNC connector.	Tektronix Part 011-0069-02.
5X Attenuator	14 dB attenuation, 50 $\Omega$ , one male and one female BNC connector.	Tektronix Part 011-0060-02.
T Adapter	Two female, one male BNC connectors.	Tektronix Part 103-0030-00.
Coaxial Cable (2 required)	50 $\Omega$ , 18-inch, two male BNC connectors.	Tektronix Part 012-0076-00.
Coaxial Cable (2 required)	50 $\Omega$ , 42-inch, two male BNC connectors.	Tektronix Part 012-0057-01.
50 $\Omega$ Termination (3 required)	Feedthrough, 2% accuracy, BNC connectors.	Tektronix Part 011-0049-01.
BNC Female to BNC Female Adapter		Tektronix Part 103-0028-00.
BNC Male to BNC Male Adapter		Tektronix Part 103-0029-00.
N to BNC adapter (for RF Synthesizer front-panel output)	N male to BNC female.	Tektronix Part 103-0045-00.
Power Divider with BNC adapters	> 1 GHz bandwidth, 50 $\Omega$ coaxial, > 6 dB load isolation.	Tektronix Part 015-1014-00 with SMA to BNC adapters (3 each 015-1018-00, 015-1012-00) or 017-0082-00 with GR to BNC adapters (3 each 017-0063-00).
Torx Screwdriver and Tips	Magnetic screwdriver T-10 T-15 T-20	Tektronix Part No. 003-0293-00 003-0814-00 003-0966-00 003-0866-00.
16 pin DIP clip	Compatible with DIP ICs.	Tektronix Part 003-0709-00.
Integrated Circuit Extracting Tool	IC Insertion-Extraction Pliers 28-pin type.	General Tool P/N U505BG or equiv.
Circuit Board Removal Tools	Straight-slot screwdriver, large, needle-nose pliers, nutdrivers, 3/16", 1/4", 7/16".	



# Using the CATS Software

The CATS (Computer Aided Test System) software resides on the 5 1/4 inch floppy disk originally packaged at the front of this manual. You will need an MSDOS system disk version 2.1 or newer to boot your PC. The CATS software disk should be kept as a master copy, not used as a "working" disk. The following instructions describe how to make a working copy of the CATS software. Instructions are also given below for installing the CATS software on a hard disk system. PC commands can be entered as upper or lower case characters.

There are a few operating conditions that must be observed when setting up a PC controller. First, the CATS software should NOT be used on a PC tied to a network. Doing this could cause the PC to miss important messages or data from the mainframe resulting in test errors. RAM resident ("Terminate and stay resident") programs can be another source of problems. Check that no programs other than MSDOS are loaded at the time your PC is booted. This could produce an Out of Memory error or other system problems. Finally, make certain that a color graphics adapter card is not installed. This will produce "snow" on the PC display during testing.

## Creating a Working Disk For a Dual-Floppy Drive System

To create a working copy of the CATS software:

- a. With the MSDOS system disk in drive A, enter the command  
`DISKCOPY B: A:`
- b. The PC will prompt you to put the source disk (i.e., the CATS Master) in drive B and the blank disk in drive A.
- c. Replace the MSDOS disk with a blank disk and put the CATS Master disk in drive B, press Return.
- d. When copying is complete, remove the CATS Master disk and store it in a safe place.

To format a disk for data logging:

- a. Put a blank floppy disk (unformatted) in drive B.
- b. With the MSDOS system disk in drive A, enter the command

`FORMAT B:`

## Installing CATS Software on a Hard Disk System

To install the CATS software on your hard disk, select the drive in which the CATS disk resides (e.g., A:) then enter the following command:

`INSTALL diskname`

where *diskname* is a letter from A-D that represents your hard disk. The INSTALL command creates a TEKCATS directory on your hard disk then copies all the files from the Master disk TEKCATS directory to the newly created TEKCATS directory. If a TEKCATS directory already exists on your hard disk, the INSTALL command will overwrite the existing CATS files but not your log files.

## Running the CATS Software

The CATS software should not be started until the mainframe oscilloscope under test is properly configured as described later under Mainframe Preparation.

Once the CATS software is installed and the mainframe is properly configured for testing, you can invoke the CATS software with the command

```
11300CAL
```

On a dual floppy drive system, enter this command when the working copy of the CATS disk is in drive A and drive A is selected (A:). For a hard disk system, change to the TEKCATS directory (CD \TEKCATS) before invoking the CATS software. Alternately, you can add the TEKCATS directory to your executive path with the PATH command (refer to your MSDOS manual).

Once the CATS software is running, you will be prompted to:

- Enter your name,
- Set the RS-232 port in the Utility menu,
- Check/Set the current date and time,
- Select the type of mainframe (11301 or 11302) being checked, and
- Verify that the serial number read from the mainframe's internal EEROM is correct (i.e., matches the front panel serial number). If the internal serial number is incorrect enter the correct number when prompted. The entered serial number will be stored internally.

The PC will initialize the powered-up mainframe. When properly booted the CATS software will display the test list menu.

## Selecting Menu Items: Default Selection is Highlighted

The CATS software presents menus with status information at the top, selections or prompt messages in the middle, and data entry at the bottom. Each selection has a number that must be entered to select the item.

In most menus more than one selection is possible. The software tries to anticipate the usual selection and highlights it as the default. Simply pressing the Return key will select the highlighted item. If another selection is desired, enter its number as displayed.

When the procedure directs you to start a test, find the test from the alphabetical test list menu and enter its corresponding number. The list of tests is large enough to require two screens (or pages) of tests. Press the space bar to switch to the second page or back to the first.

In some adjustment tests, the function keys F5, F6, F7, and F8 are assigned to increase or decrease some parameter of a displayed trace. You will be prompted at the bottom of the screen when it is time to use these function keys.

## Exiting from CATS and Other F1 Key Options

Once running, the CATS software can be exited at anytime by pressing the F1 key then entering "4" to leave the program. Pressing F1 also offers other options that include:

1. Return to (Restart) previous test or menu. This allows you to restart a test after exiting it.
2. Back up one menu level. When exiting from a CATS test, this will return you to the test list menu.
3. Back up to the top menu (i.e., 11301 or 11302 selection).
4. Leave CATS for the MSDOS environment. This terminates the CATS software and closes the log file.
5. Redraw the PC screen.
6. Display CATS environment information, including the CATSOS version number and the application (APPL) version number. These version numbers are necessary when reporting a problem with the CATS software.

## Storing and Reloading Mainframe Calibration Constants

The CATS test list menu contains a utility test that provides the ability to store the full set of mainframe EEROM calibration constants in a file and, if necessary, reload them into a mainframe.

The store option reads all mainframe calibration constants and saves them in the file that you specify. This utility may be used before starting repair or adjustment of a mainframe to provide a recovery file in case something extraordinary happens, such as a loss of power in the building.

The restore test provides the ability to load a complete set of mainframe calibration constants from a PC disk file into the mainframe. The file can be either one stored earlier as a backup/recovery file or a special Default file contained on the CATS disk. The Default file is a complete set of default calibration constants. The Default file should only be used following a catastrophic failure such as the A11 Main Processor board losing its calibration constants memory (EEROM). After a major repair, you may be asked to load the Default file into the mainframe to put the instrument in an initial operating state. The full Checks and Adjustments procedure must be performed following the loading of the Default file. The CATS disk actually contains separate Default files for the 11301 (DEFAULT.301) and for the 11302 (DEFAULT.302). Use the appropriate file for your mainframe.

### Using the Utility Tests

To use the utility tests, perform the steps listed under Mainframe Preparation (just before Part 1 of the procedure) then select the test **utility** from the test list menu. You will be prompted to choose one of the following:

- 1) **DUT\_const > file**—This selection stores the current calibration constants from the mainframe in a file. After selection, you will be asked to enter the desired disk drive and a name for the file such as b:\directory\calconst.dat.
- 2) **const\_file > DUT**—This selection loads a file containing calibration constants into the mainframe. After selection, you will be asked to enter the desired disk drive and the name of the calibration constants file.

3) **Exit menu** – This selection returns you to the test list menu.

When the transfer of calibration constants is complete, the PC will display the status of the transfer.

## Test Data Logging

All automated CATS tests log results to a data log file while manual test data may be logged on a blank form provided on the CATS disk. For dual-floppy drive systems, the data log file is written to the root directory on drive B. On hard disk systems, the data file is written to the \TEKCATS directory. The instrument serial number is written to the data file as is the date and the time testing began. The data log file is named with the instrument serial number followed by a .DLF suffix (e.g., B010000.DLF). This ensures a unique log file for each mainframe checked.

If only checks are performed, then the results of the checks are logged for each test run. If an adjustment is made in a test, only the results of the adjustment are logged for that test. Subsequent runs of the CATS software (i.e., leaving the CATS software, then restarting it later) on a particular instrument will append the new log data to the end of the old log file rather than overwriting it.

Manual test do not have data logged automatically, so a blank report form is provided on the CATS software disk for logging test results. Before starting the CATS software, enter the following command to print the blank form:

```
PRINT diskname:BLANKFM.RPT
```

### *Types of Data and Limits Logged*

The logged data includes Pass/Fail status and, if appropriate, the low limit, high limit and current value for a checked parameter. The test limits stored in the log file are, in most cases, the advertised specifications. The logged limits may be more lenient than those used in the check portions of the procedure and they are definitely more lenient than the limits used for the adjustment portions. The log file is an ASCII character file but the data is logged in a somewhat cryptic format.

### *Printing the Log File*

A report generator is included on the CATS software disk that will print out a specified test log file on an Epson compatible printer connected to the PC. The report generator takes the cryptic information in the log file and puts it into a useful table format before printing. The report generator is a program separate from CATS and must be invoked when the CATS software is not running. To print a test log enter the following command:

```
CATSRPT diskname:filename.dlf > prn
```

A complete record of the Checks and Adjustments procedure consists of both the printed log file and the manually filled in report.

### *Removing Old Log Files*

To remove old log files enter the DOS command

```
ERASE diskname:filename.dlf.
```

For example, ERASE B:B010000.DLF would remove the data file named B01000.DLF from drive B.

## CATS SRQ Messages

The mainframe sends Service Requests (SRQs) to the PC when it needs attention. Usually the SRQ indicates completion of the last command sent by the PC. If the SRQ is not a response to a command and is unexpected by the PC, then it is a spurious SRQ. The spurious SRQ may indicate an error condition in the mainframe, an incorrect plug-in unit for the current test, or many other possibilities. For a complete list of SRQ messages, refer to the ASCII interface discussion in the appropriate users manual.

When a spurious SRQ occurs, the CATS software displays a status window as a troubleshooting aid for the operator. The window gives the SRQ status byte, the event number, and a description of the unexpected event.

To remove the SRQ message press the carriage return. If the PC continues to display an SRQ message, check the settings, connections and On/Off state of all test equipment, and the mainframe. After all has been checked, press the F1 key and select number 1, **RETURN (RERUN)**. This will restart the failed test.

### *Clearing a Continuous SRQ Condition*

In unusual circumstances, the mainframe may continually generate SRQs or it may not respond to keyboard input. If either of these conditions occur, press the F1 key and select number 4 to leave CATS. When the MSDOS prompt appears restart the CATS software. The CATS software has a buffer in which it stores SRQ messages from the oscilloscope mainframe. Quitting the CATS software clears this buffer.

If the SRQ message reappears, it may mean that the PC to oscilloscope mainframe communication interface is not synchronized. To correct this condition, leave CATS, initialize the mainframe, then cycle the oscilloscope mainframe power off and on to reset the interface. It is not necessary to power down the PC. When the mainframe oscilloscope is powered up, restart the CATS software.

## CATS Error Messages

The PC generates error messages whenever the CATS is unable to run properly or when a CATS test fails. The error message display will briefly describe the problem. If the failure follows an adjustment attempt, then refer to the Troubleshooting section. The following is a partial list of errors and their probable causes:

- **Out of Memory.** The CATS software needs more memory (free RAM) to run. Either another program is running in RAM or the PC does not have adequate RAM (640 kbytes) installed to run the CATS software.
- **Read Failed.** The PC was unable to communicate with the oscilloscope mainframe because the power was off or possibly because the RS-232 cable was not properly connected.
- **Write Failed.** The PC was unable to communicate with the oscilloscope mainframe because the power was off or possibly because the RS-232 cable was not properly connected.

## Using this Procedure

This 11301 mainframe procedure involves three types of tests; entirely manual tests, semi-automated tests that require you to adjust waveforms and enter information on the PC, and fully automated tests that simply post Pass/Fail status upon completion. The sequence of testing will normally progress from Part 1 to the end of the procedure. An abbreviated list of procedure Parts is discussed below that focuses on Performance Specifications only. Another sequence may result from checks required after replacing an FRU. See the Maintenance section for information on checks required after FRU replacement. This procedure should be performed only on the 11301 mainframe.

If you are unable to properly make an adjustment specified in a procedure Part, refer to the Troubleshooting section of this manual.

## Format Conventions

In these procedures, capital letters within the body of text identify front-panel controls, indicators, and connectors (for example, MEASURE) on the mainframe and plug-in. Bold letters identify menu labels, display messages, and PC test names. For example, **Vertical Cursors** is a menu entry while **autocal\_vert** is a PC test name. Initial capital letters identify connectors, controls, and indicators on associated test equipment (for example, Position). Initial capital letters also identify adjustments inside the plug-in (for example Vertical Size).

A heading system is used to readily identify the steps that contain performance verification and/or adjustment instructions. For example, if **CHECK** is the first word of a step, a functional limit or electrical specification is checked. If **ADJUST** appears in the title, the step involves an electrical adjustment.

## Terms Used

Below are the definitions of some abbreviations and terms used in the manual procedure and on the PC prompts:

**DUT**—Device under test, which refers to the oscilloscope mainframe being checked and adjusted.

**Enter**—Information must be typed in on the PC followed by a carriage return.

**Start**—Find the indicated test from the test list menu and enter its corresponding number.

## Mainframe Menu Selection and Measurement Techniques

Details on measurement techniques and instructions for making menu selections on the oscilloscope mainframe are generally not included in this procedure. Comprehensive descriptions of menus and instrument features are located in the mainframe User's Reference manual.

The mainframe tutorial manual is strongly recommended to familiarize the first-time user with the mainframe controls and features.

## Abbreviated Sequence for Performance Verification

All of the Checks and Adjustments procedure Parts should be performed annually. But, a reduced set of procedure Parts may be performed semi-annually to verify instrument performance.

If an adjustment is required in one of these procedure Parts, then it may be necessary to perform some checks that occur earlier in the full procedure. For example, if the Vertical High Frequency Response is adjusted, you will need to perform the following procedure Parts:

- Part 12 – Vertical Center
- Part 15 – Plug-in Interface Gains (vertical section)
- Part 16 – Vertical Center (second pass)
- Part 19 – Beam Registration
- Part 20 – Cursor to Graticule Match

Perform the following procedure Parts to verify instrument performance.

1. Part 1 – Extended Diagnostics
2. Part 2 – CVR Accuracy
3. Part 7 – Front Panel Display Adjustments
4. Part 20 – Cursor to Graticule Match
5. Part 21 – Reference Oscillator
6. Part 22 – Front Panel Calibrator
7. Part 24 – Install Instrument Covers
8. Part 25 – Sweep Timing Accuracy
9. Part 26 – Delta Delay Accuracy
10. Part 28 – Vertical High Frequency Response
11. Part 29 – Vertical/Measurement Accuracy
12. Part 33 – Trigger Accuracy
13. Part 35 – Center Compartment X-Axis Accuracy
14. Part 38 – Frequency Accuracy
15. Part 39 – External A and B Input Sensitivity
16. Part 40 – 2 ns Holdoff
17. Part 41 – Holdoff by Events
18. Part 42 – Time Interval Using Sweeps
19. Part 43 – Minimum Time Interval
20. Part 44 – Store Cal Constants

Only the CVR Accuracy test requires access to the calibration constants. So, unless an adjustment is made during the CVR test, the Store Cal Constants procedure Part may be omitted.

# Mainframe Preparation

The following information describes how to configure the mainframe for check/adjustment, connect the PC, and start the CATS software. For a detailed discussion of the CATS software see the discussion Using the CATS Software earlier in Section 2.

## 1. Remove Instrument Covers

Set the ON/STANDBY switch to STANDBY. Remove the top and bottom covers from the mainframe. Use a coin to turn the four clasps on the top and bottom covers. First, lift up the front of each cover, then remove it.

## 2. Setting DIP Switches for Testing

Locate the DIP switch on the A11 Main Processor board (see Fig. 2-1) at the top, rear of the mainframe. All DIP switches are normally in the Open position and should be returned to that position after all tests are performed. For testing, set DIP switch numbers 3, 4, and 5 to the closed position.

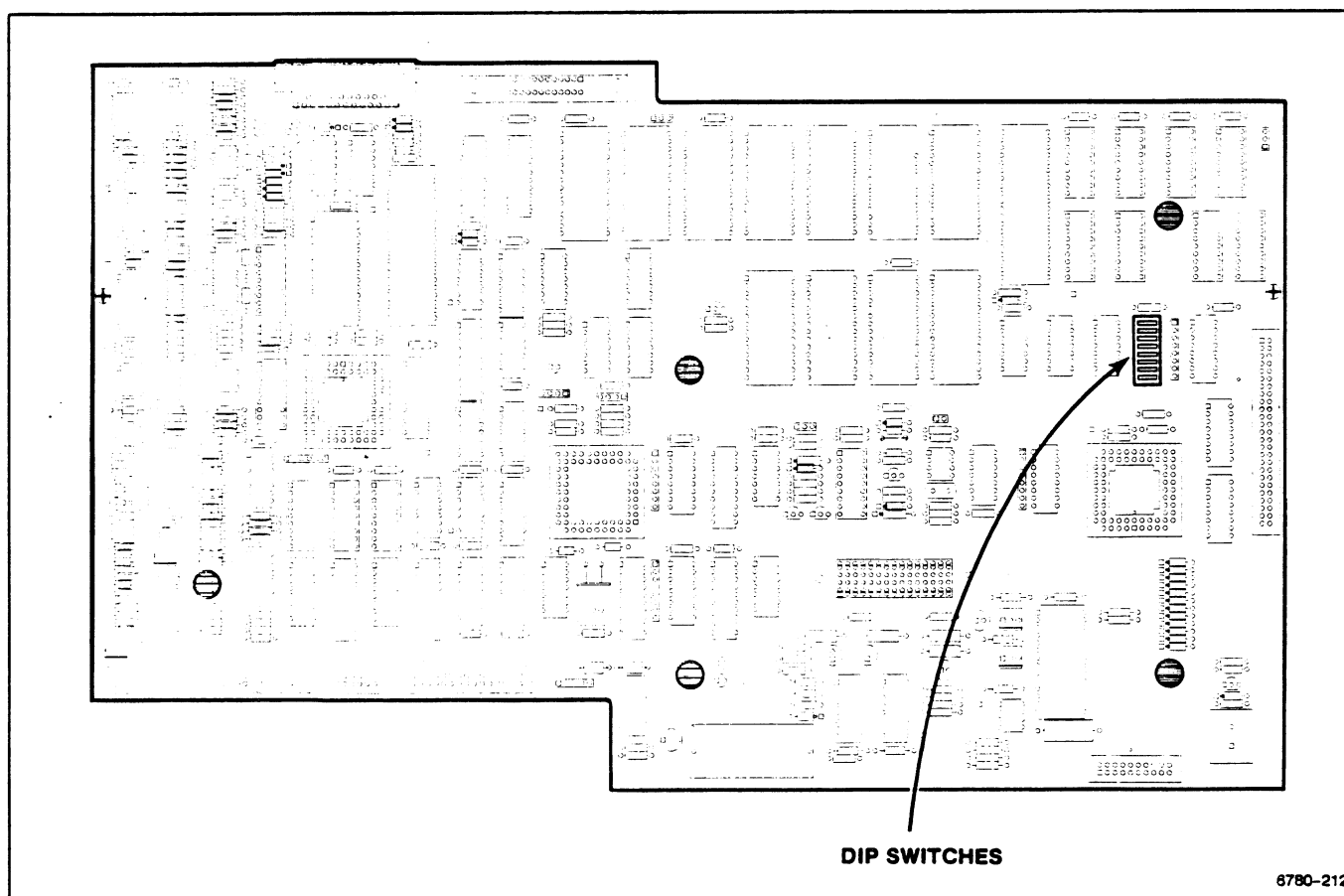

Figure 2-1. Location of DIP Switch on the A11 Main Processor board.



When closed, switch number 3 inhibits self-test at power up, number 4 permits Enhanced Accuracy shortly after power up instead of waiting the normal 20 minutes, and number 5 permits the RS-232 controller to access to the calibration commands and constants.

### 3. *Connect RS-232 Cable, Power Up Mainframe, Set RS-232*

Connect the RS-232 cable (see Test Equipment earlier) from the PC COM1 port to the mainframe under test. The cable should be long enough to allow the mainframe to be moved about while connected. Turn the rear-panel PRINCIPAL POWER SWITCH and the ON/STANDBY switch to ON. When the mainframe is powered up, press the UTILITY button and select RS-232. Verify or set the following settings:

    baud rate . . . . . 4800  
    stop bits . . . . . 1  
    character bits . . . . . 8  
    parity . . . . . none

### 4. *Power up the PC*

Apply power to the PC if not already powered up. You will need an MSDOS system disk that is version 2.1 or newer. When MSDOS is booted it may prompt you to enter the correct time and date. If prompted, enter the current time and date. If you are not prompted for the time and date, use the MSDOS commands TIME and DATE to set them. The current time and date are used to date the test log file. Print out the manual report form (PRINT *diskname*: BLANKFM.RPT) as described previously under Test Data Logging.

### 5. *Start the CATS Software*

With the mainframe already powered up, remove the MSDOS system disk and put in the CATS working disk. Put a blank formatted disk in drive B for the data log. Invoke the CATS tests by entering 11300CAL. On a hard disk system, change directories into the TEKCATS directory, then enter 11300CAL. See Using the CATS Software earlier in this section for more details.

### 6. *Go to Part 1 of the Procedure*

Proceed to Part 1 of the procedure unless you are performing the procedure Parts listed in Abbreviated Sequence for Performance Verification Only or a special list of procedure Parts following FRU replacement. Set the mainframe beeper volume to an audible level by pressing the UTILITY button and selecting Soft or Loud, whichever is your environment requires.

# Part 1 – Power Supply

**Description** This test checks the power supply voltages.

## Examine Supply Voltages

### Setup

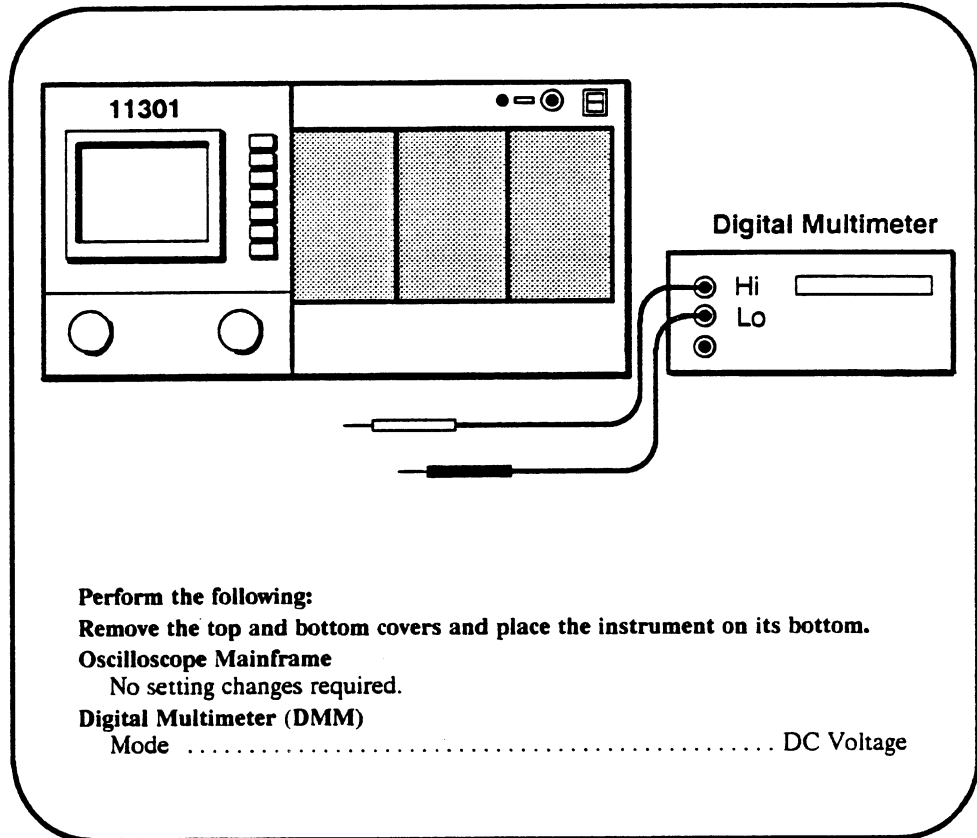

### Procedure

- a. Verify the following analog supply voltages at the associated connector pins located on the A11 Main Processor board. See Figure 2-2.

Analog Voltage	Connector-Pin #	Tolerance
-50 V	J90-5	$\pm 1$ V
+ 50 V	J90-3	$\pm 1$ V
-15 V	J90-11	$\pm 0.3$ V
+ 15 V	J90-9	$\pm 0.3$ V
-5 V	J90-2	$\pm 0.15$ V
+ 5 V	J90-26	$\pm 0.15$ V

- b. Place the instrument on its right side, then **CHECK** the supply test pin J63-2 (see Figure 2-3) for  $+5.1\text{ V} \pm 50\text{ mV}$ . The jumper J63 (an unused 6 pin connector) is located on the bottom at the left rear of the instrument, on the A2 Power Supply module. Use ground test point TP510 on the A13 Scope Logic board.



DO NOT attempt to optimize the power supply adjustment settings if the reading is within the stated limits. If the readings are outside the stated limits, proceed to the following Adjust steps.

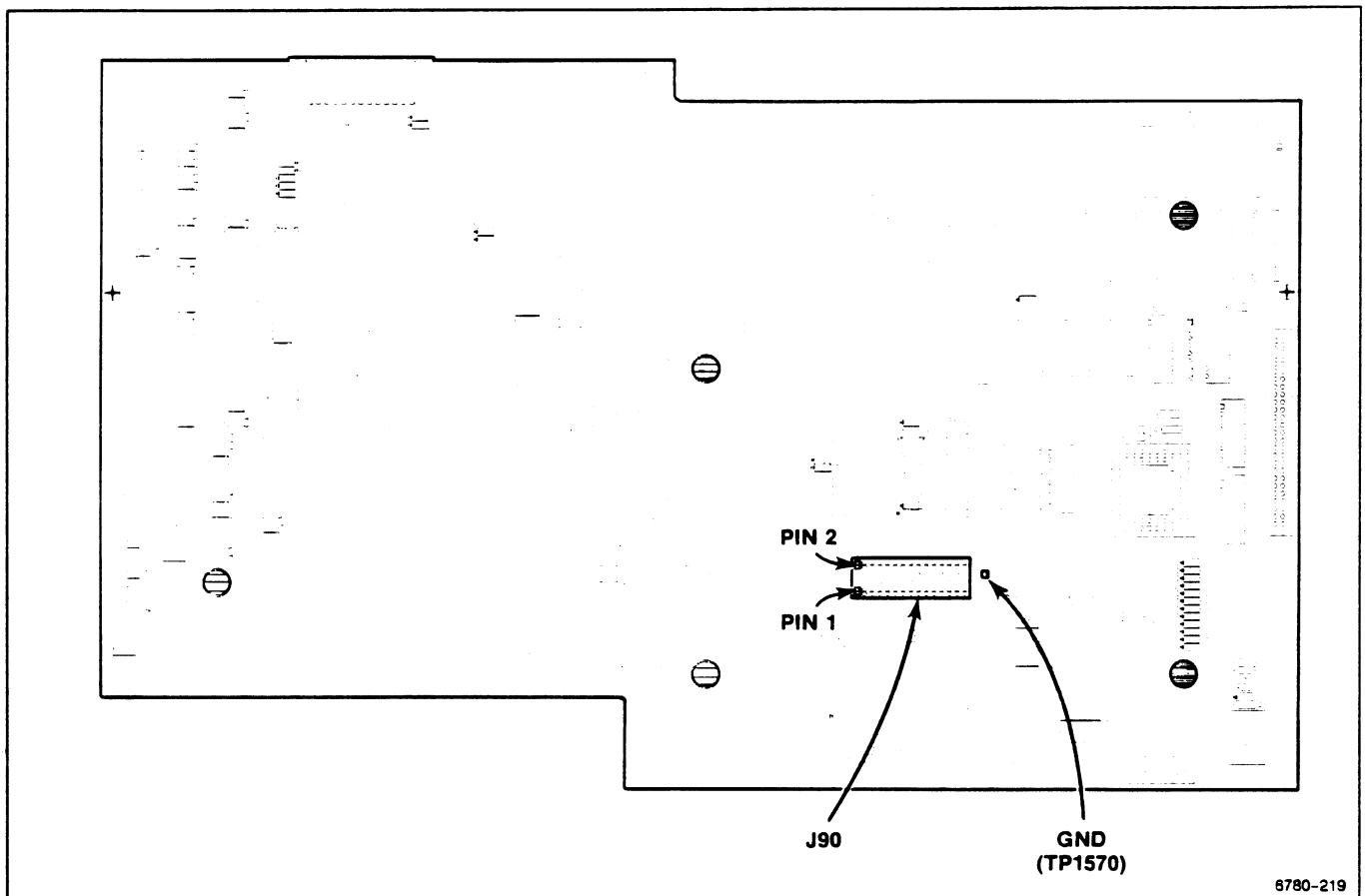

Figure 2-2. Location of the J90 connector on the A11 Main Processor board.

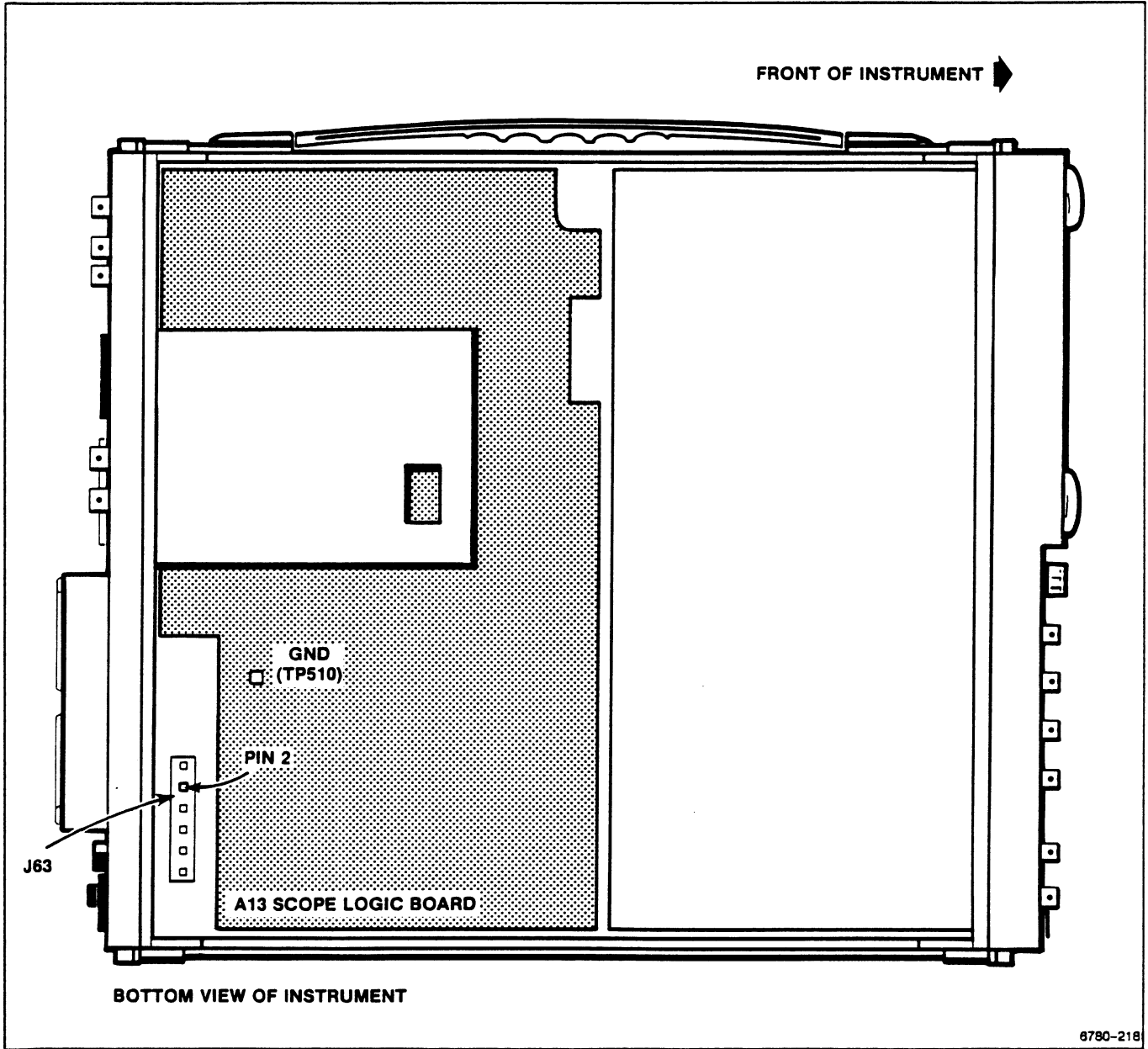
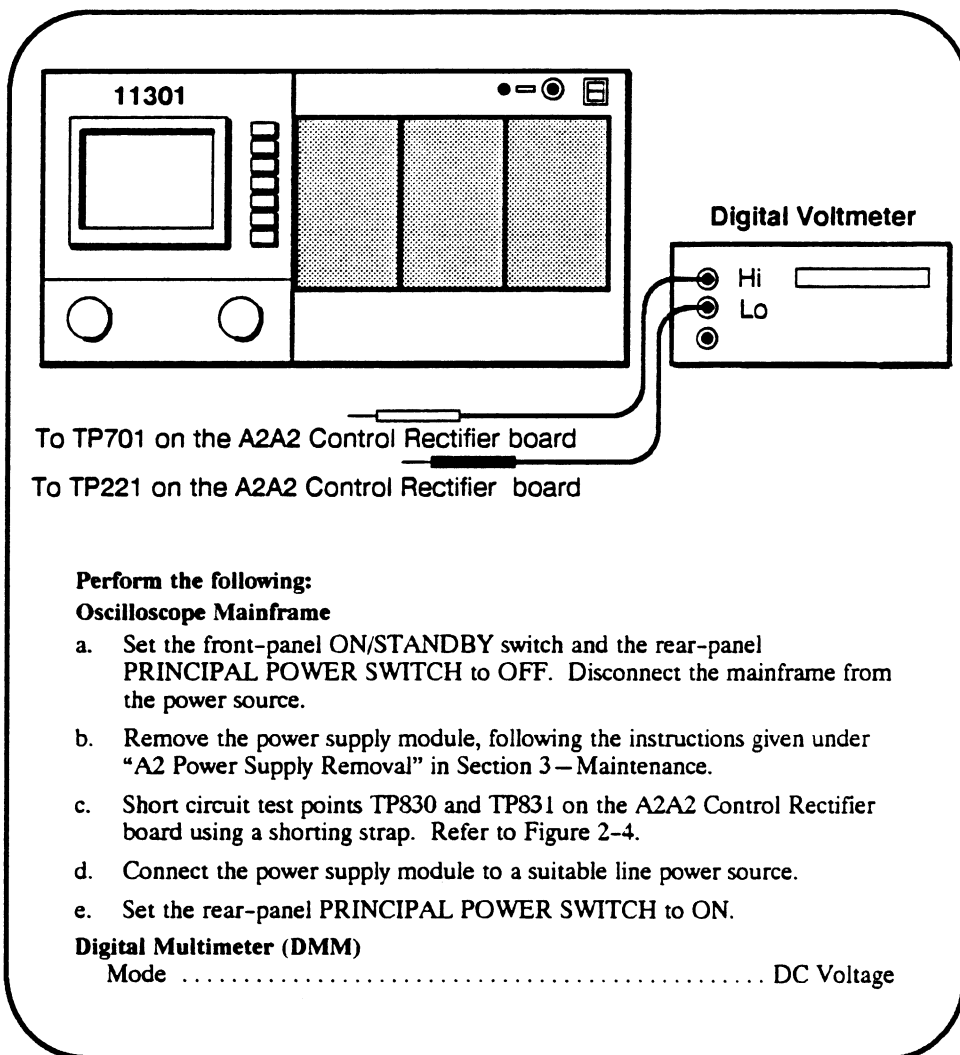

Figure 2-3. Location of J63-2, the +5.1 V test point on the A2 Power Supply.

## Adjust +5.2 V Reference

### Setup



### Procedure

#### WARNING

*Extreme caution must be used when making the following adjustment due to the dangerous potentials present.*

- CHECK**—the DMM for a reading of +5.20 V, within the limits of +5.15 V and +5.25 V.



DO NOT adjust if the reading is within the stated limits.

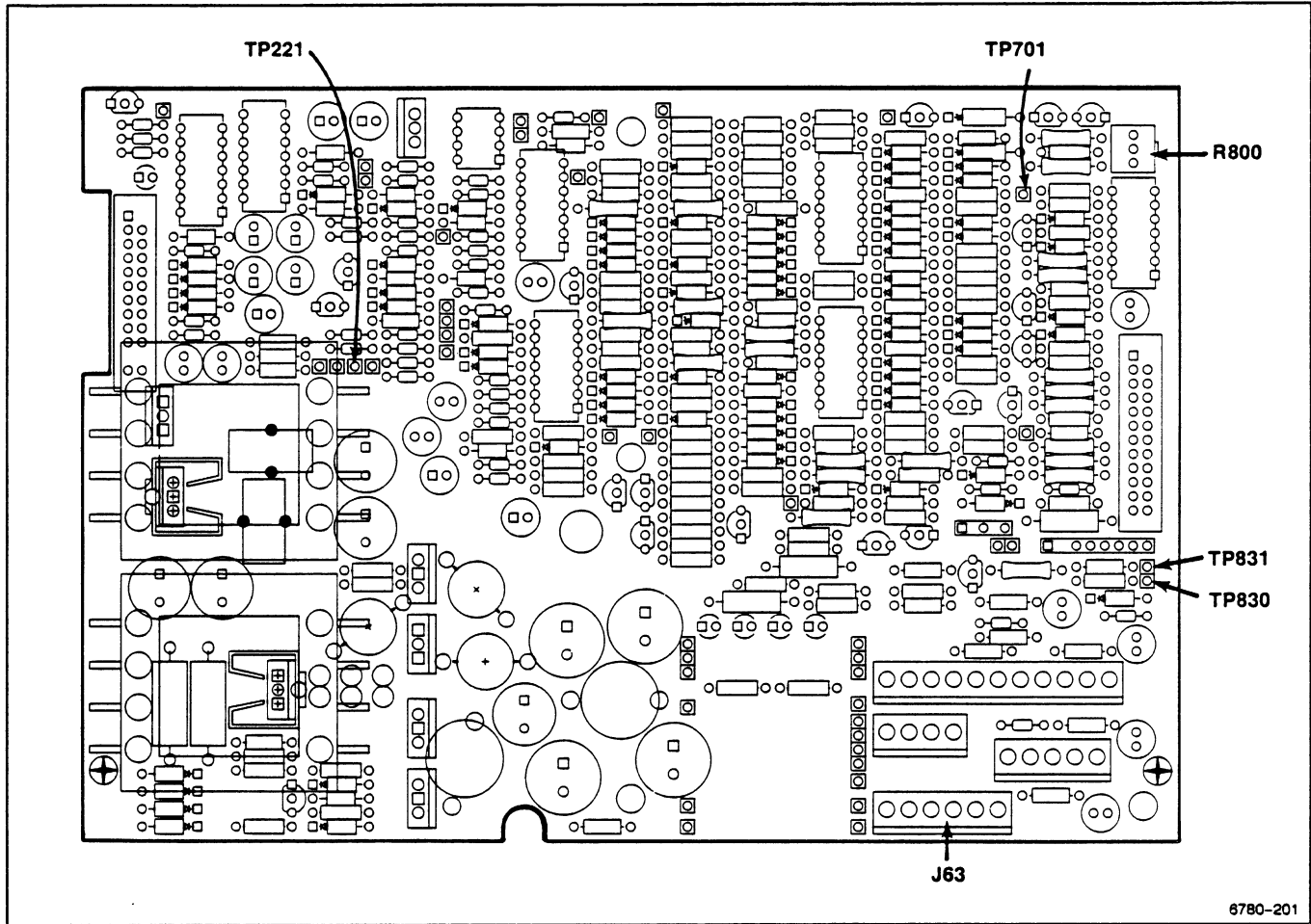
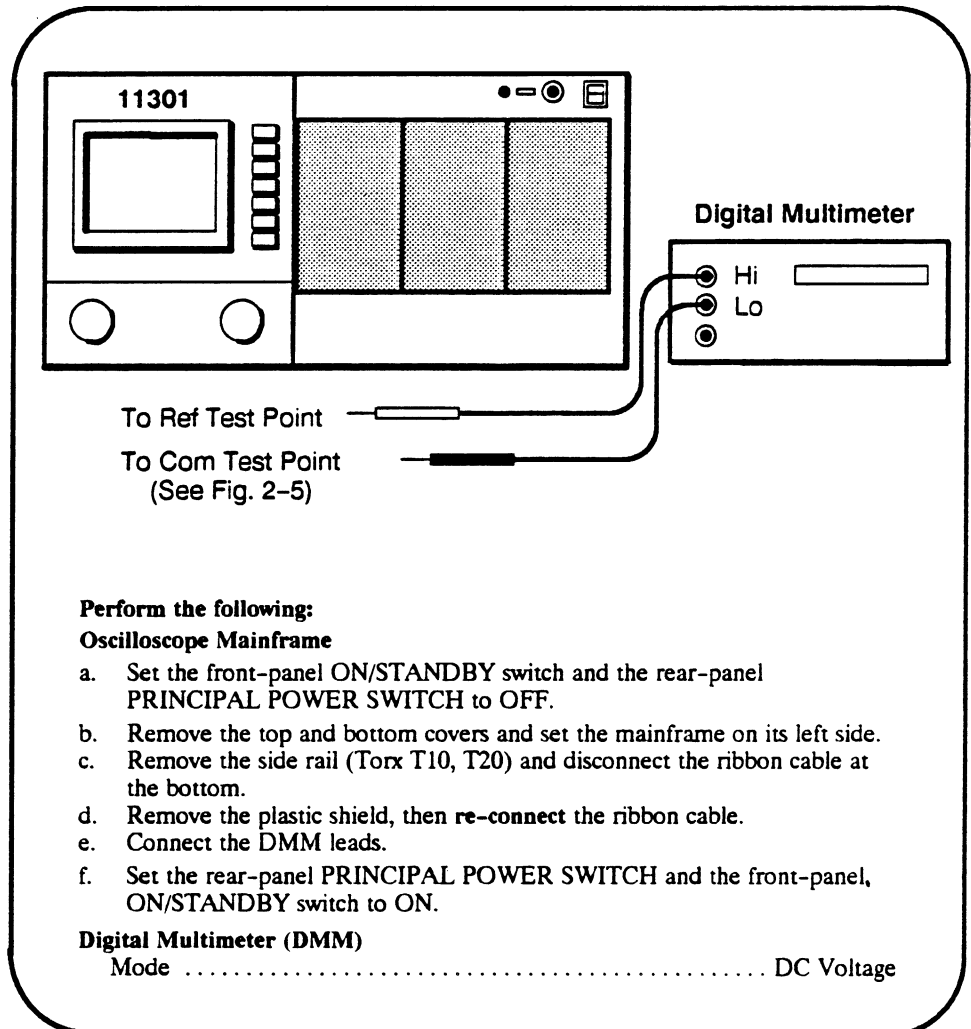

**Figure 2-4. A2A2 Control Rectifier board test point and adjustment locations.**

- b. *ADJUST* – +5.2 V Ref adjustment R800 for +5.20 V.
- c. Remove the DMM leads from the test points.
- d. Set the rear-panel PRINCIPAL POWER SWITCH to OFF. Disconnect the instrument from the power source. Remove the shorting strap and all test leads.
- e. Replace the power supply in the mainframe.
- f. Set the rear-panel PRINCIPAL POWER SWITCH to ON, and the front-panel ON/STANDBY switch to ON.

# Adjust Regulator Reference

## Setup



## Procedure

### WARNING

*Extreme caution must be used when making the following adjustment due to the dangerous potentials present.*

- CHECK**—the DMM for a reading of +10.00 V, within the limits of +9.95 V and +10.05 V.



DO NOT adjust if the reading is within the stated limits.

- ADJUST**— +10 V Ref adjustment R830 on the A4 Regulator board for +10.00 V. See Figure 2-5.

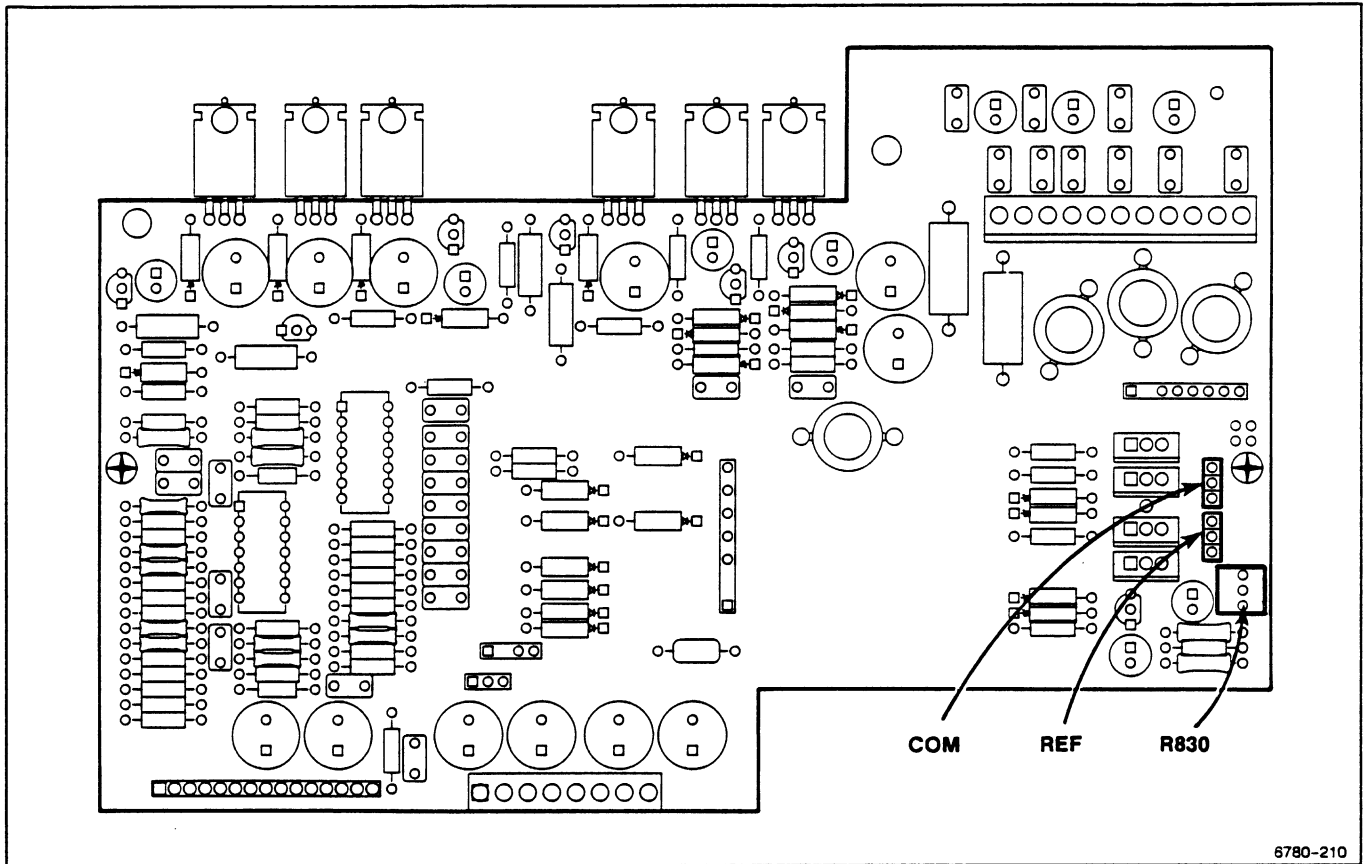

**Figure 2-5. A4 Regulator board test point and adjustment locations.**

- c. Set the front-panel ON/STANDBY switch and the rear-panel PRINCIPAL POWER SWITCH to OFF.
- d. Remove the test leads, replace the plastic shield and side rail by reversing the procedure described in the Setup.
- f. Set the rear-panel PRINCIPAL POWER SWITCH and the front-panel ON/STANDBY switch to ON.



---

## Part 2 – Extended Diagnostics

---

### Description

This test uses the mainframe's internal Diagnostic tests to verify the overall functionality of the instrument.

### Setup

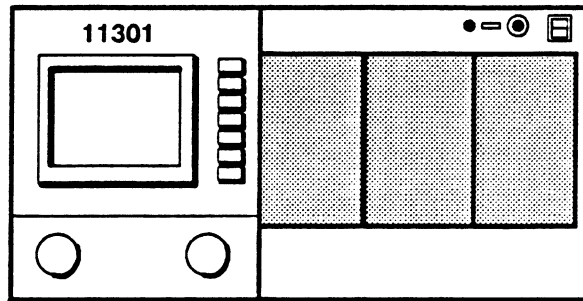

Powered up without failure and in the normal operating mode. No Signal Standardizers should be installed while the test is running.

### Procedure

- a. Press the **UTILITY** button.
- b. Select **EXT TEST** in the Utility menu,.
- c. Select **Run** under the message **For Qualified Service Personnel Only**, then select **RUN** in the lower right corner of the screen. During the two minutes of testing, the screen will flash off and on. No buttons should be pressed or controls changed during the tests.
- d. **CHECK**—that the Index column of the final diagnostics menu contains only **Pass** entries or, for empty plug-in compartments, either **L????**, **C????**, or **R????**.  
  
If any tests had a **Fail Index** status, note the adjacent **Fault** number and refer to the Diagnostics information in the Maintenance section of this manual.
- e. Return the oscilloscope to the normal operating mode by pressing the **UTILITY** button. When the message indicating the Extended Diagnostics are complete appears proceed to the next procedure Part.

## Part 3 – Touch Screen

### Description

This test checks for correct sensitivity and operation of the Touch Screen.

### Setup

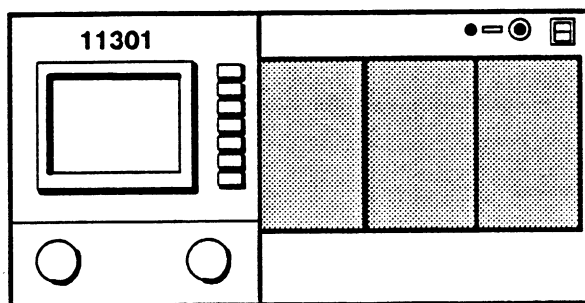

Initialize the oscilloscope's settings, then perform the following:

Oscilloscope Mainframe:

UTILITY menu ..... I/O BNC  
..... Ext for Ref Clock  
..... Press UTILITY button  
GRAT INTENSITY ..... Adjust to illuminate the graticule

### Procedure

- Touch each row and column touch area, shown shaded in Figure 2-6, one at a time. The horizontal and vertical graticule lines indicate the borders of the square touch areas on the screen.
- CHECK**—that as each area is touched, the on-screen message Counter Timer PLL unlocked disappears briefly then reappears.
- Set REFCLOCK back to INT.



DO NOT adjust the touch screen sensitivity unless the previous check failed.

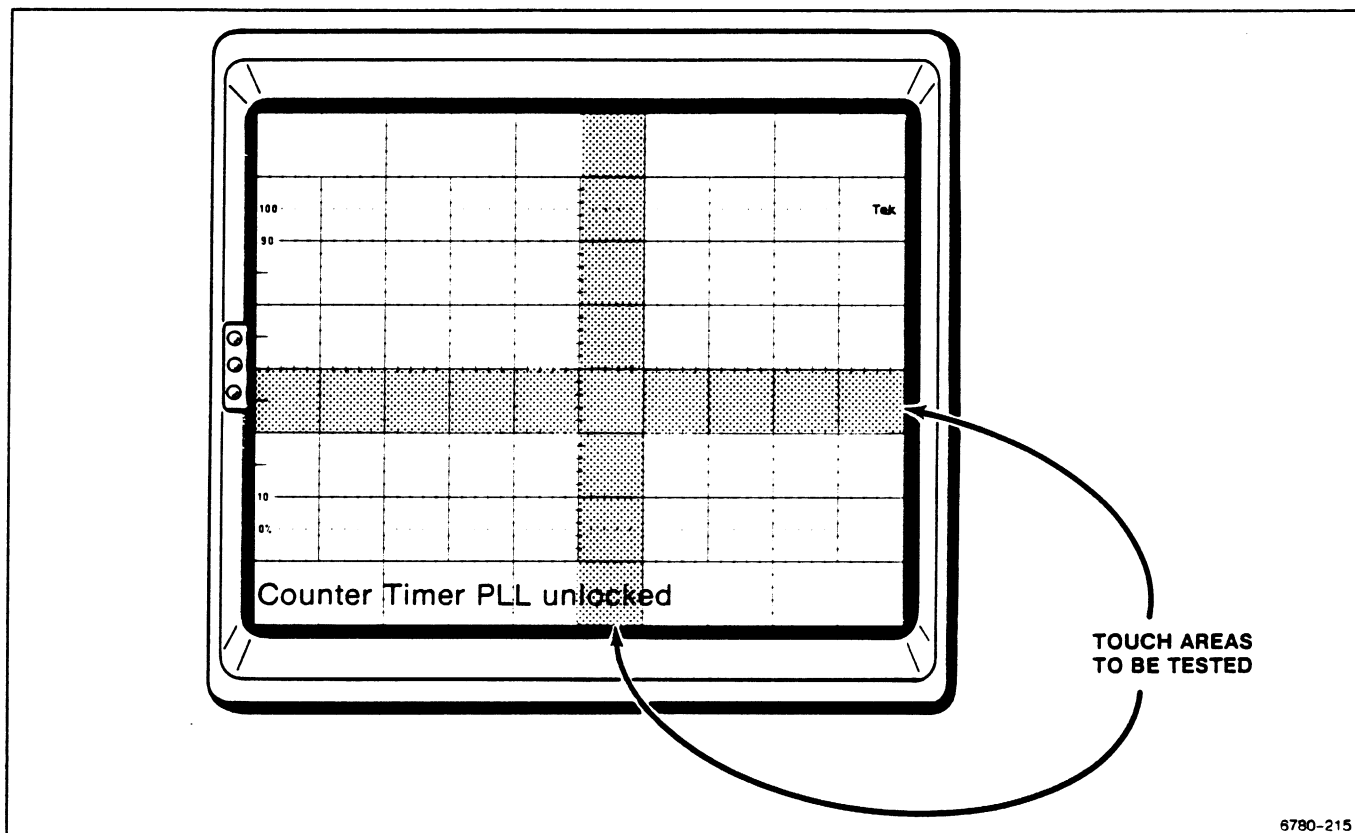
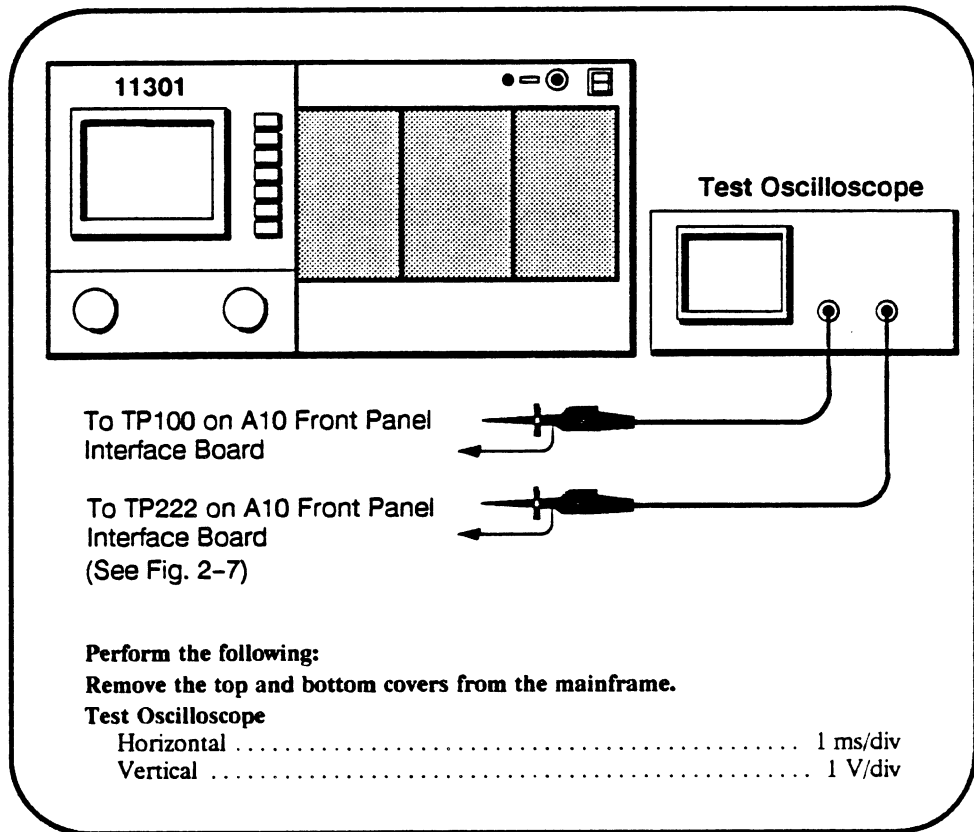

Figure 2-6. Locations of crt touch areas to test.

# Touch Screen Sensitivity Adjustment

## Setup



## Procedure

- a. The signal from TP222 should be selected as the trigger source and the signal from TP100 should be displayed.

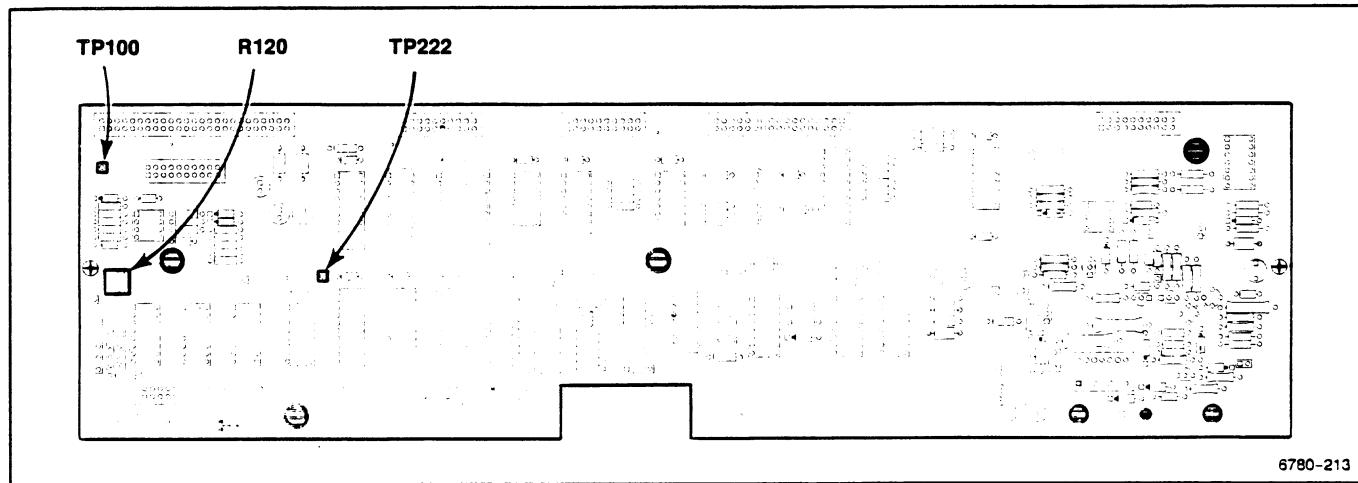
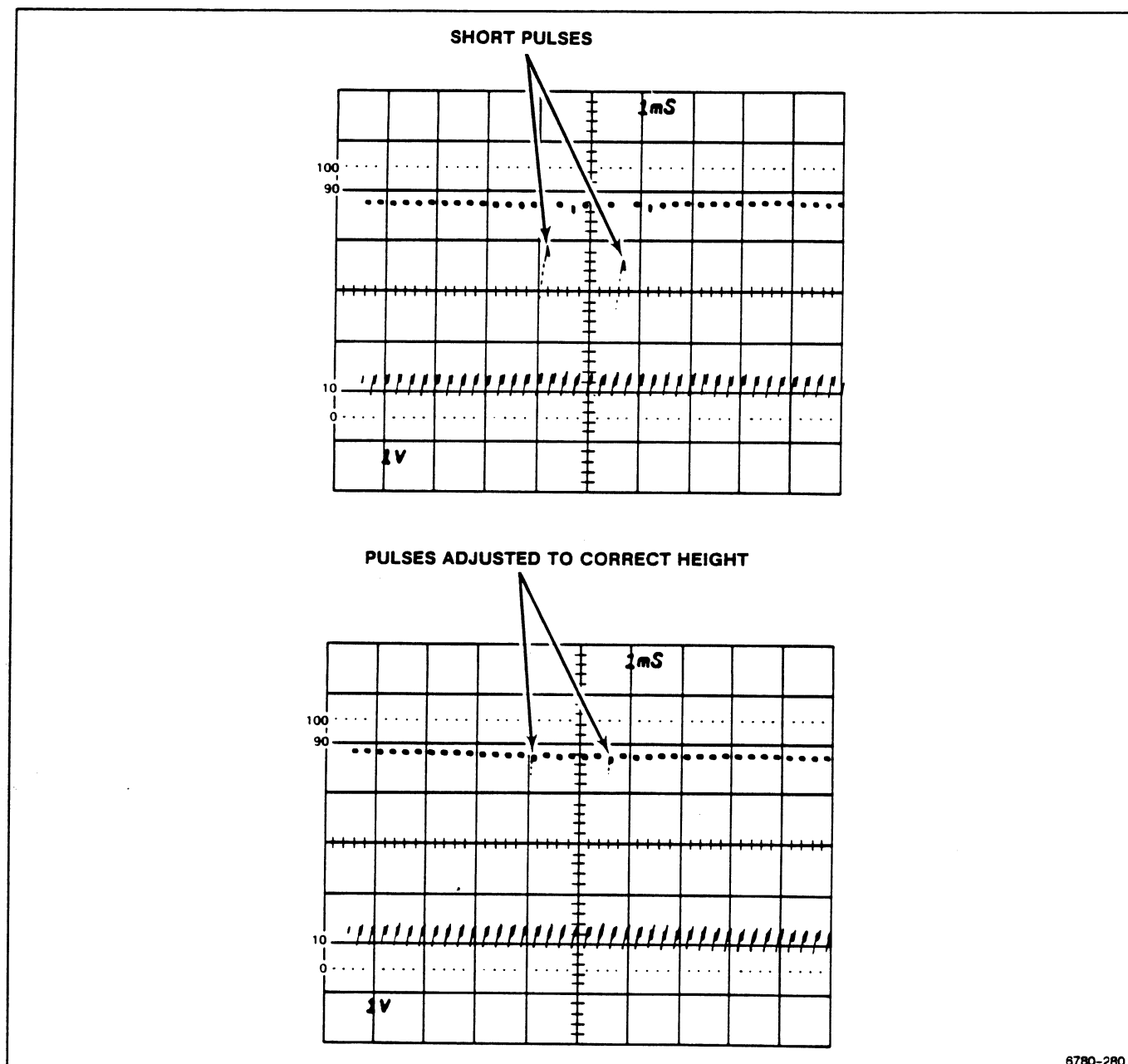

Figure 2-7. A10 Front Panel Interface board (Touch Screen) test point and adjustment locations.



**Figure 2-8. Waveform display showing Touch Screen adjustment waveforms.**

- b. Set the graticule intensity to minimum. If the room lights are exceptionally bright, partially shade the crt from the room lights. Adjust the test scope for a sweep speed of 1 ms/div. The display on the test scope should present a full sequence of 24 pulses plus part of another sequence. See Figure 2-8.
- c. Adjust R120 (sensitivity) counterclockwise to identify the “short pulses” as shown at the top of Figure 2-8.

- d. Now adjust R120 back clockwise until the short pulses just approach the level of the top line of the other 20 pulses as shown at the bottom of Figure 2-8. Do not adjust R120 further clockwise.

**NOTE**

*Ignore the very short positive-going spike at the end of each pulse.*

- e. Remove the probes from the A10 Front Panel Interface board.

# Part 4 – CVR Accuracy

## Description

This test checks the accuracy of the calibration voltage reference on the A13 Scope Logic board.

## Setup

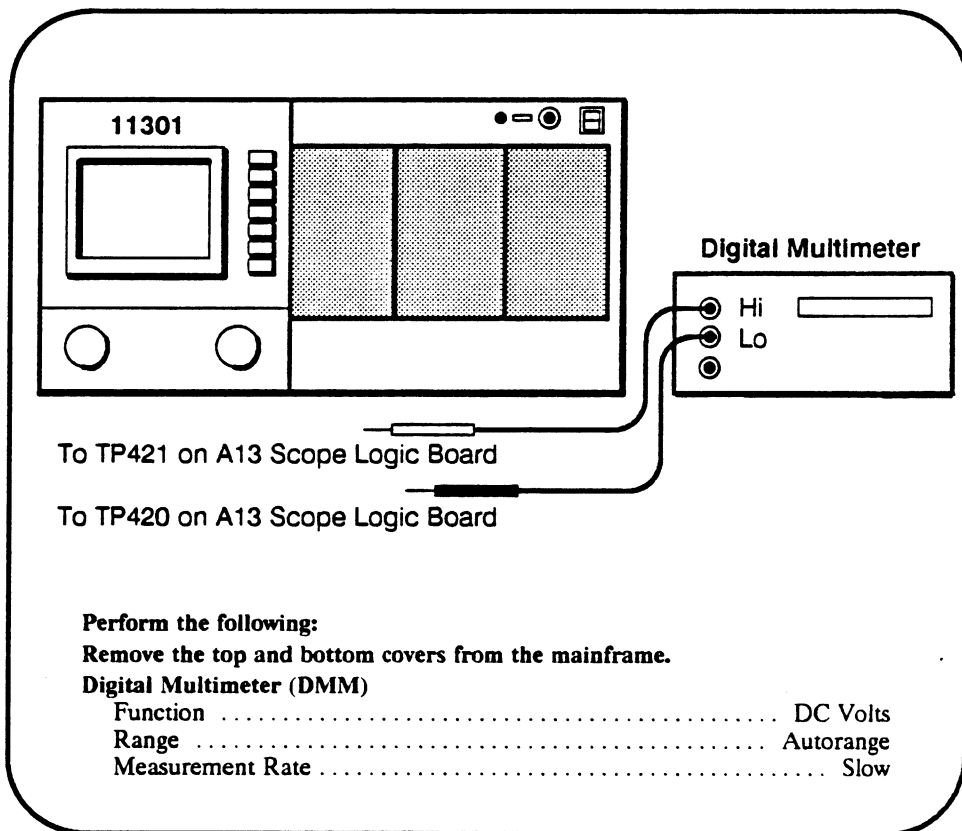

## Procedure

- In the CVR test, you will be asked to enter many precise DMM readings. To ensure high accuracy readings use short DMM leads and twist them around each other. Also, you should let the meter settle before entering the reading. The DMM readings must be entered in volts. Both decimal and exponential notation are acceptable. For example, a reading of  $-199.87$  mV could be entered as  $-0.19987$  or  $-199.87e-3$ .
- Start the test `cal_voltage_ref`. Follow the instructions given on the PC screen and enter all displayed digits of the current DMM reading when prompted.
- If the entered values are within allowed limits then the test will exit and you should proceed to the next procedure Part.



**DO NOT** attempt to optimize the adjustment settings unless requested to do so by the PC.

- When prompted, adjust R330 for an Offset of  $-10.000$  volts (see Figure 2-9) then enter the new Offset reading on the PC.
- When prompted, adjust R333 for a Gain of  $9.9951$  V then enter the new Gain DMM reading on the PC.

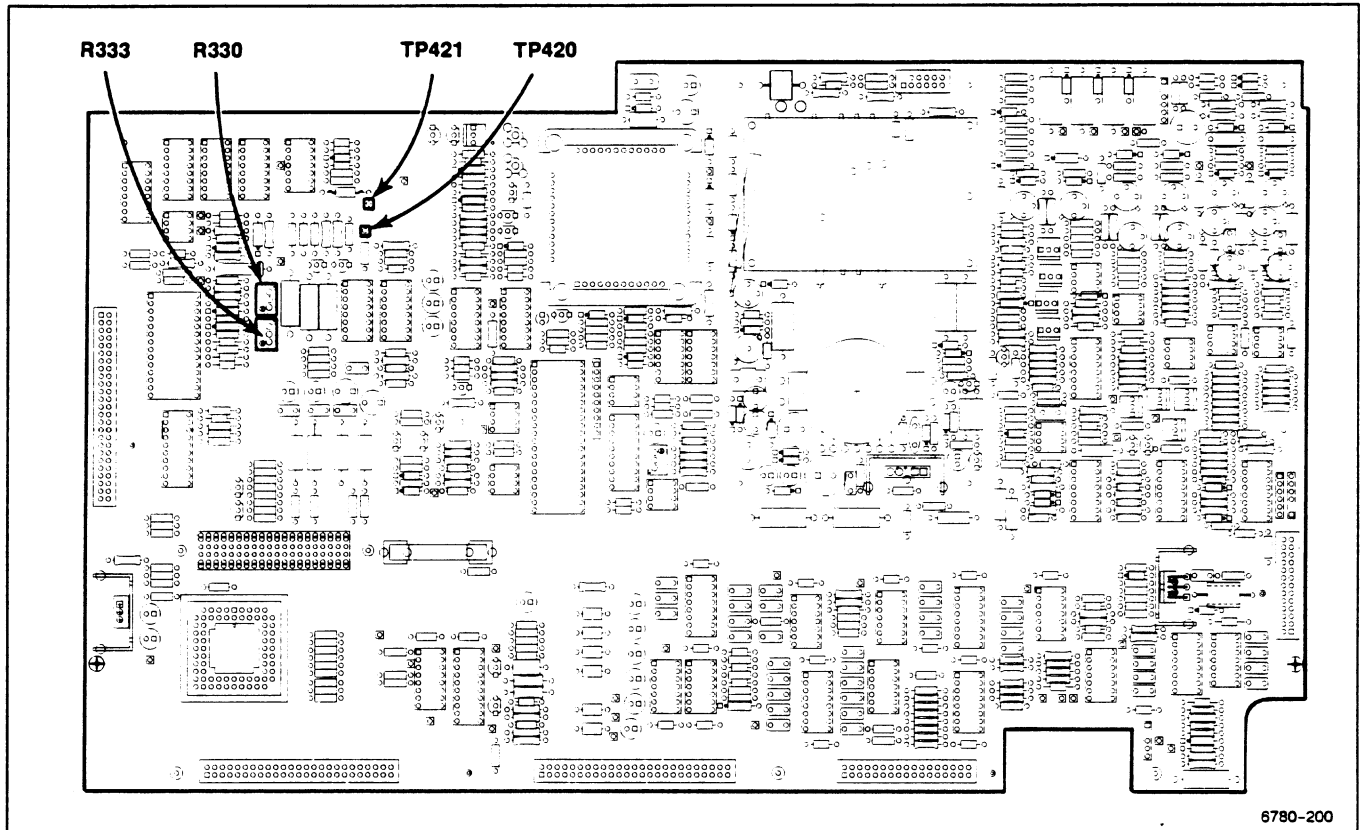

Figure 2-9. A13 Scope Logic board (CVR Accuracy) test point and adjustment locations.



---

## Part 5 – A/D Converter

---

### Description

This test check the gain and offset of the mainframe A/D converter.

### Setup

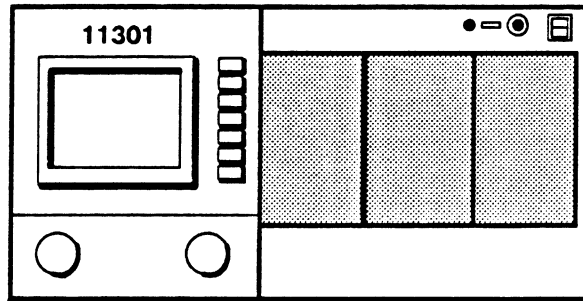

**Perform the following:**

**Remove the top and bottom covers from the mainframe.**

**No plug-in units or connections are necessary.**

### Procedure

- a. Start the `a_d_gain_offset` test. The PC will automatically check the settings for gain and offset.
- b. If the settings are not within tolerance the PC will offer the choices to exit or adjust the gain and offset.



**DO NOT** attempt to optimize the gain and offset settings if the verification passed.

- c. See Figure 2-10 for adjustment locations and follow instructions on the PC to adjust the gain and offset.

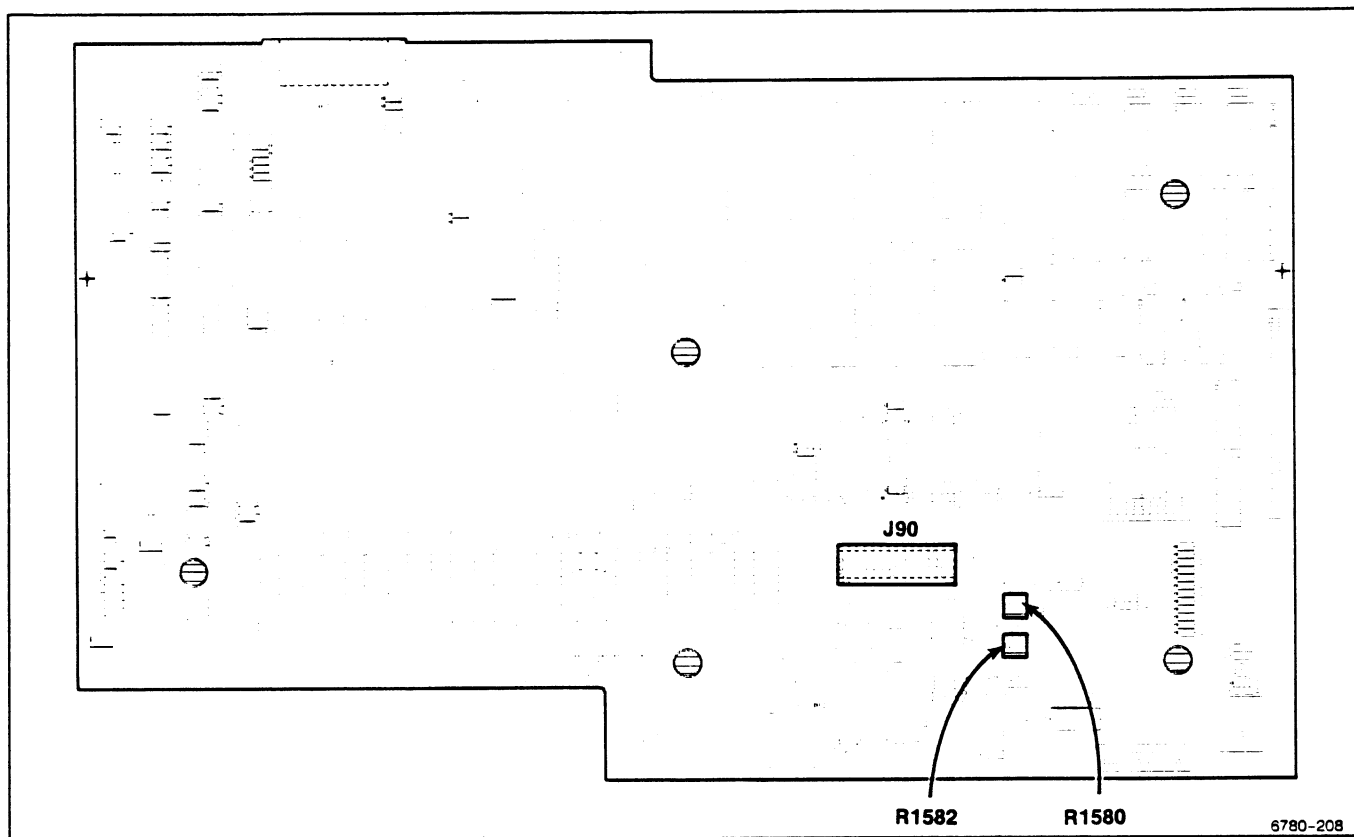

Figure 2-10. A11 Main Processor board (A/D Converter) adjustment locations.

# Part 6 – ACVS Gain

## Description

This test verifies the accuracy of the A13 Scope Logic board analog control voltages.

## Setup

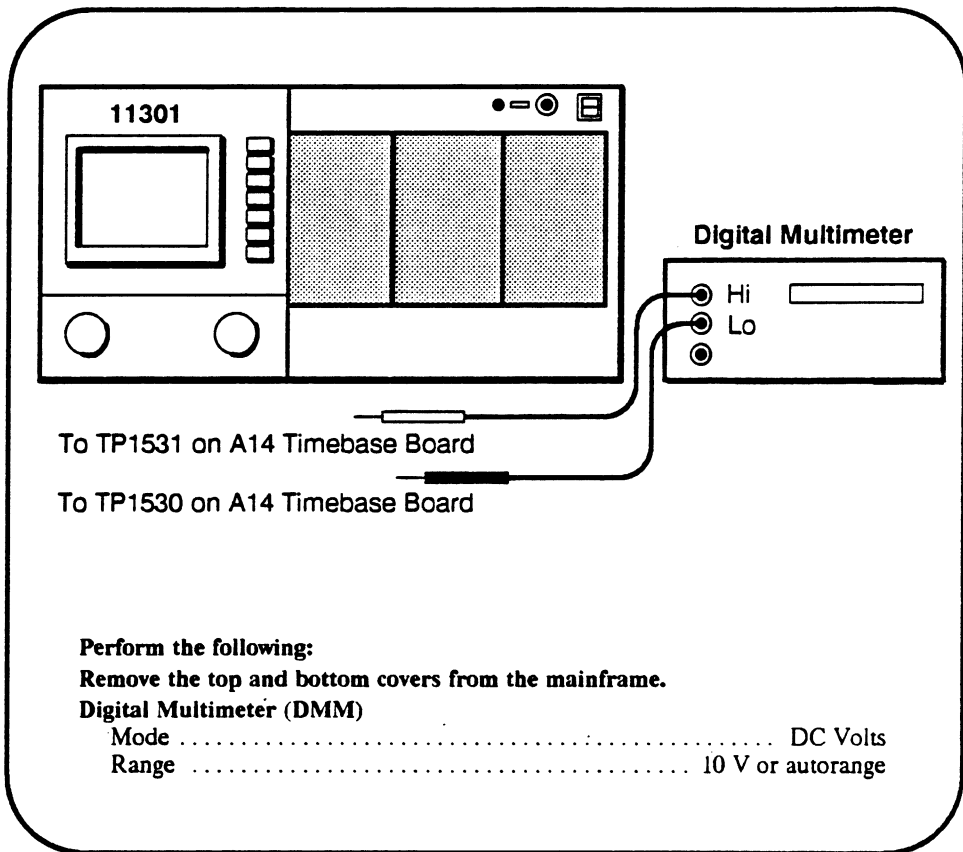

## Procedure

- Start the `acvs_gain` test. Follow the instructions given on the PC screen and enter the current DMM reading when prompted.
- If the entered values are within the allowed limits, then the test will give you the choice to exit or adjust the gain.



**DO NOT** perform the following adjustment unless the ACVS checks are out of tolerance.

- Follow the adjustment instructions on the PC. See Figure 2-12 for the adjustment location.

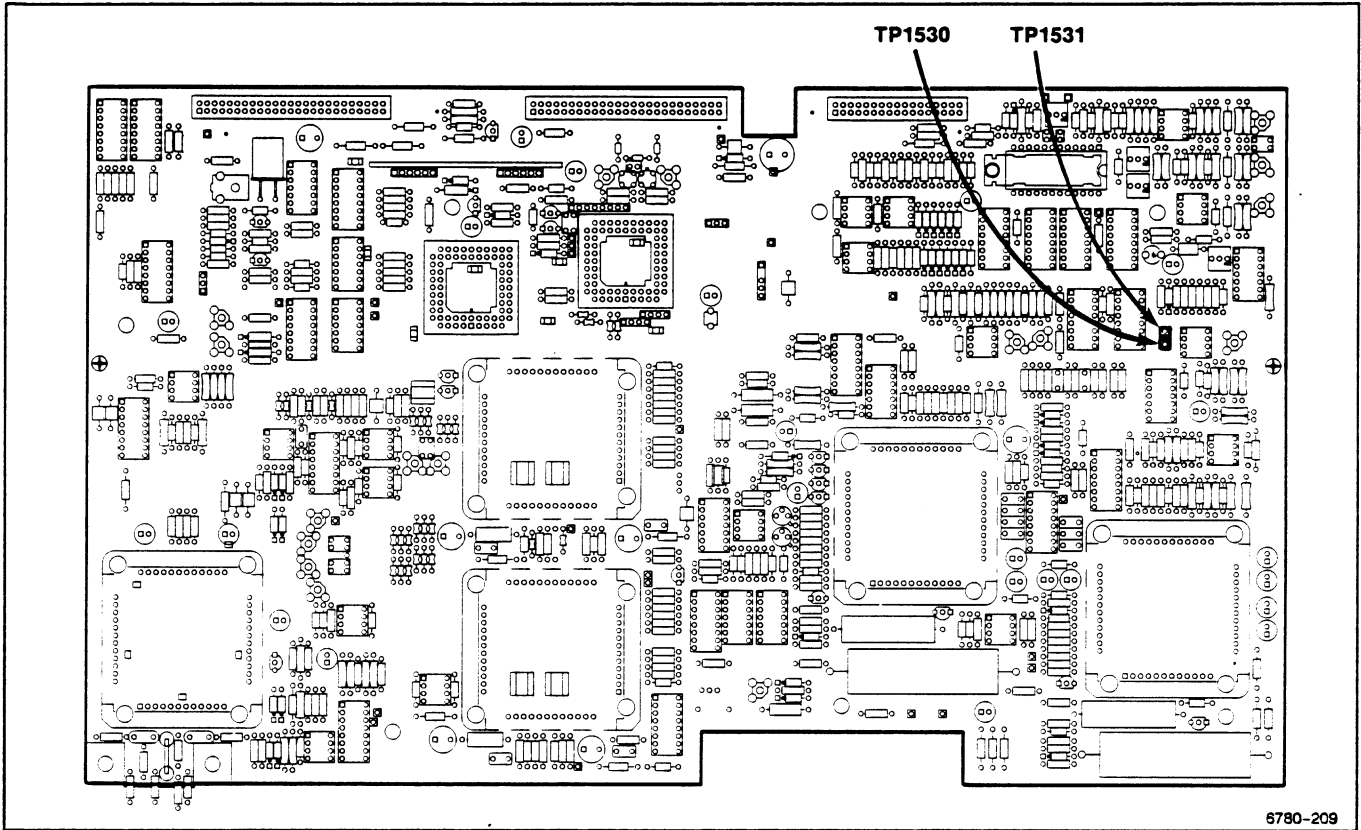

Figure 2-11. A14 Timebase board (ACVS Gain) test point locations.

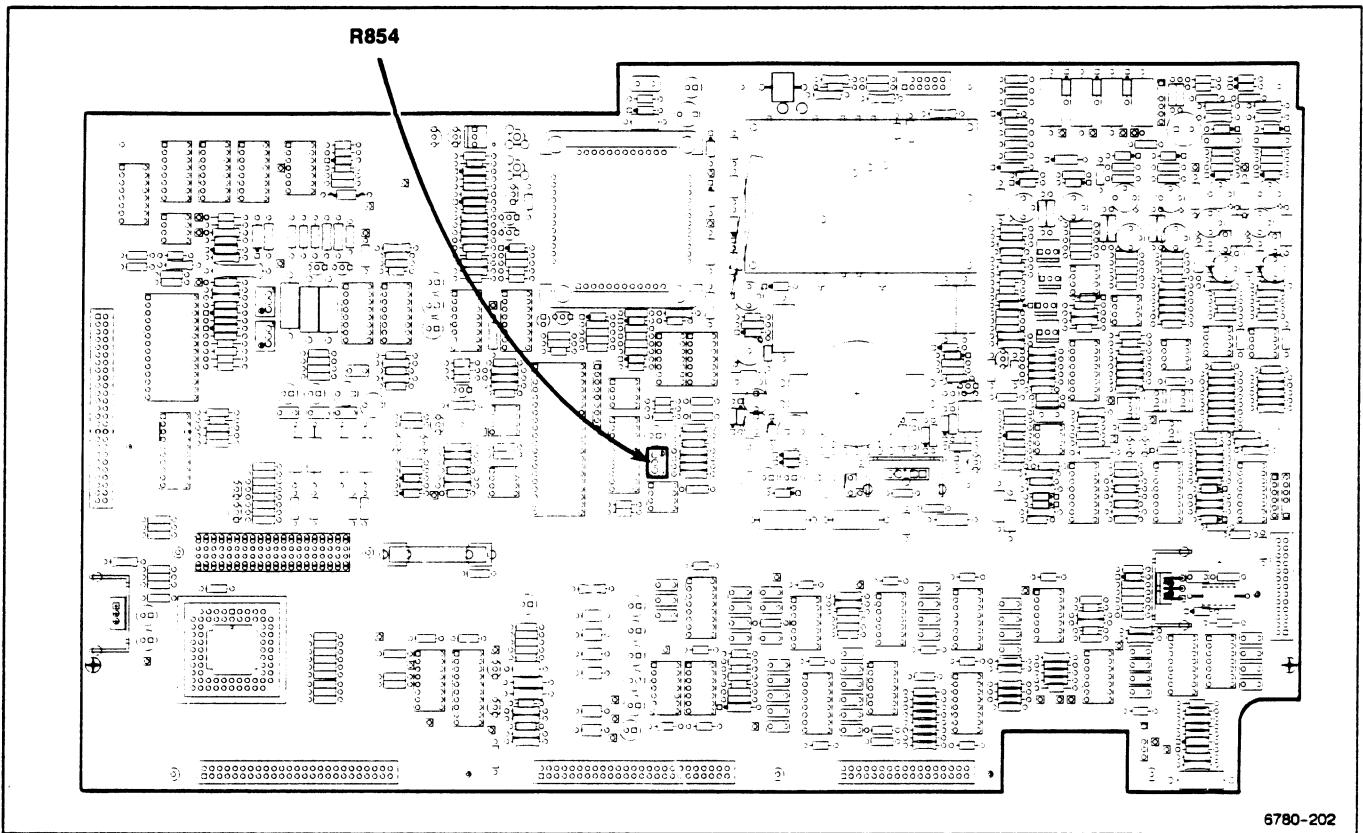

Figure 2-12. A13 Scope Logic board (ACVS Gain) adjustment location.

---

## Part 7 – Front Panel Display Adjustments

---

### Description

This test adjusts the Trace, Astigmatism, and Trace Rotation.

### Setup

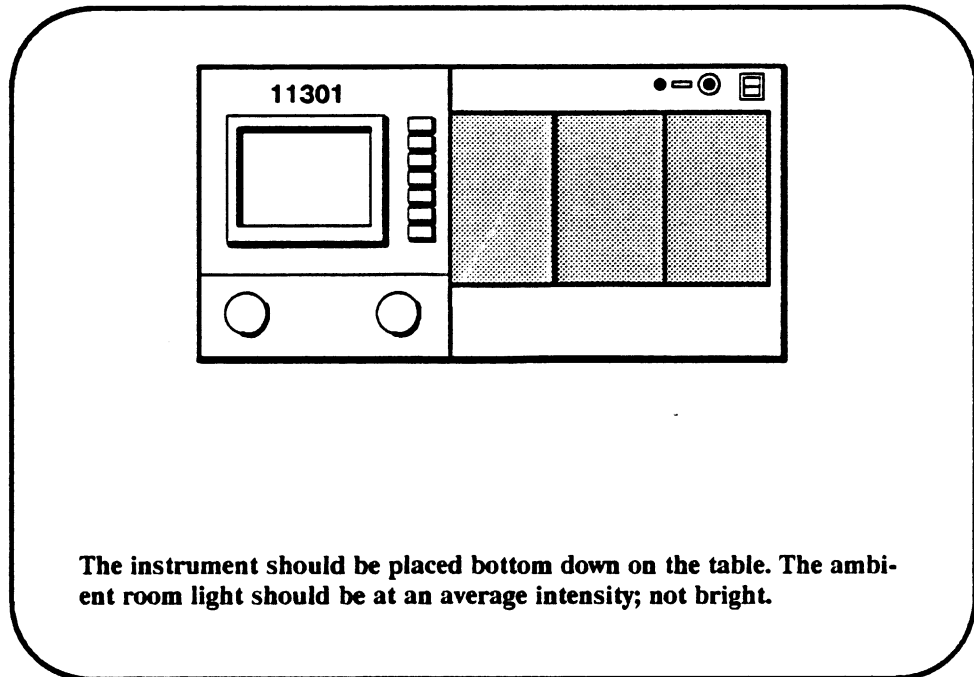

### Procedure

- a. Press the DISP ADJ button.
- b. With the left and right knobs set to FINE, adjust the knobs for the best overall clarity and focus of the displayed characters. The left and right knobs adjust Focus and Astigmatism, respectively.
- c. Select **Trace Rot**, then adjust the right knob to set the reference trace parallel to the center graticule line.

---

## Part 8 – Display Quality

---

### Description

This test provides performance checks and adjustment procedures to attain the maximum quality crt display.

#### NOTE

*The instrument must have been on for at least 20 minutes before checking or adjusting any of the functions listed below. If the power is turned off briefly to change the plug-ins, then it is not necessary to wait the full 20 minutes again.*

There are four sections in this part:

- Grid Bias
- Y-Axis Alignment
- Display Clarity and Geometry
- High Drive Focus

# Grid Bias

## Setup

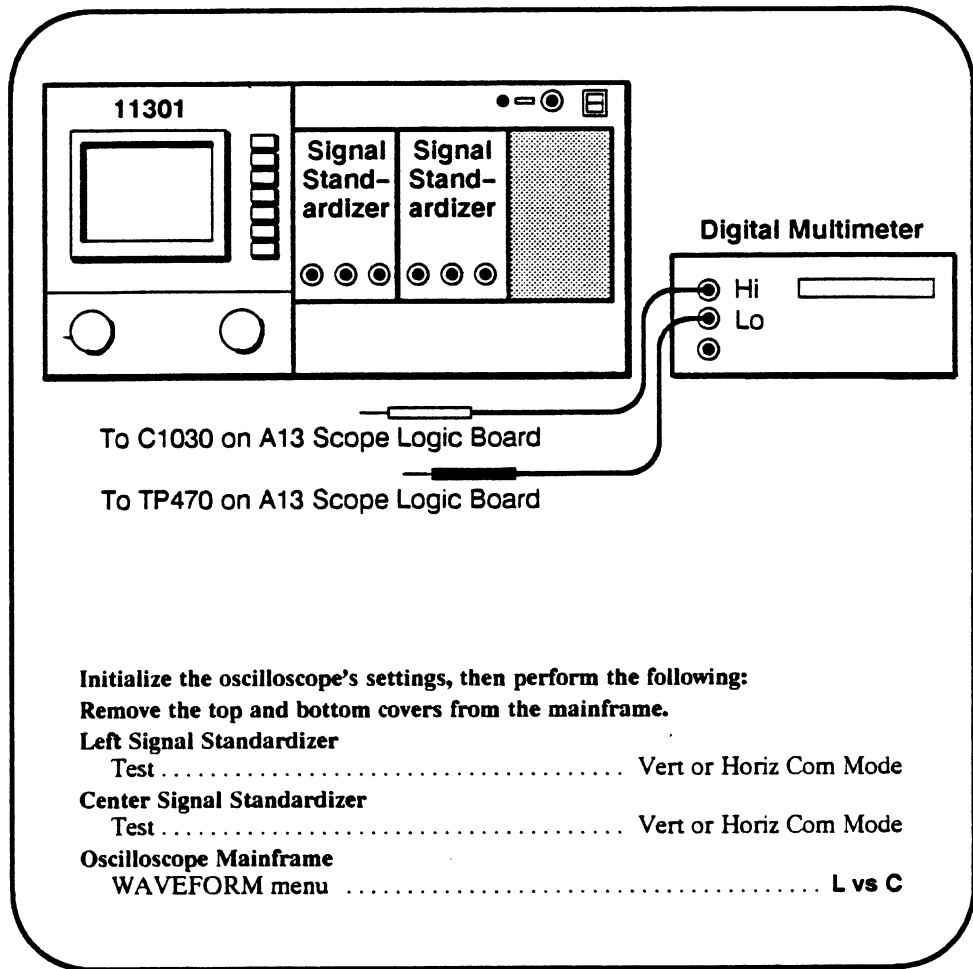

## Procedure

### NOTE

*The mainframe should be warmed up at least 20 minutes before starting this test. A stable internal temperature is very important.*

- a. Adjust the front-panel INTENSITY control knob to set the CHAR, XY and GRAT INTENSITY to their minimum values. The beeper sounds when the minimum value is reached.
- b. Shield the screen from ambient light and increase the XY INTENSITY until a dot is just barely visible on the screen.
- c. If the dot is very close to a graticule line, change the mode of one or both of the Signal Standardizers to Vert or Horiz Aux In. Then, use the Position control of the Signal Standardizer to move the dot away from the graticule.



- d. With the dot just barely visible, turn the XY INTENSITY knob counterclockwise and count the clicks until the mainframe's beeper sounds (the minimum setting).
- e. **CHECK** – that the number of clicks is  $\geq 20$ , but  $\leq 36$ .



DO NOT attempt to adjust the grid bias if the Grid Bias check just performed is within tolerance. Proceed to the Y-Axis Alignment Check/Adjust that follows, if the grid bias is correct.

- f. Adjust the XY INTENSITY knob counterclockwise to its minimum value. A beeper sounds to indicate that the minimum value is reached.
- g. Adjust the CHAR and GRAT INTENSITY to their minimum values.
- h. **ADJUST** – R1330 on the A13 Scope Logic board so that a dot is visible on the screen. Shield the screen from room light and readjust R1330 so that the dot on the screen is just extinguished. Refer to Figure 2-13 for the location of this adjustment.
- i. Adjust the CHAR INTENSITY to a comfortable viewing level.

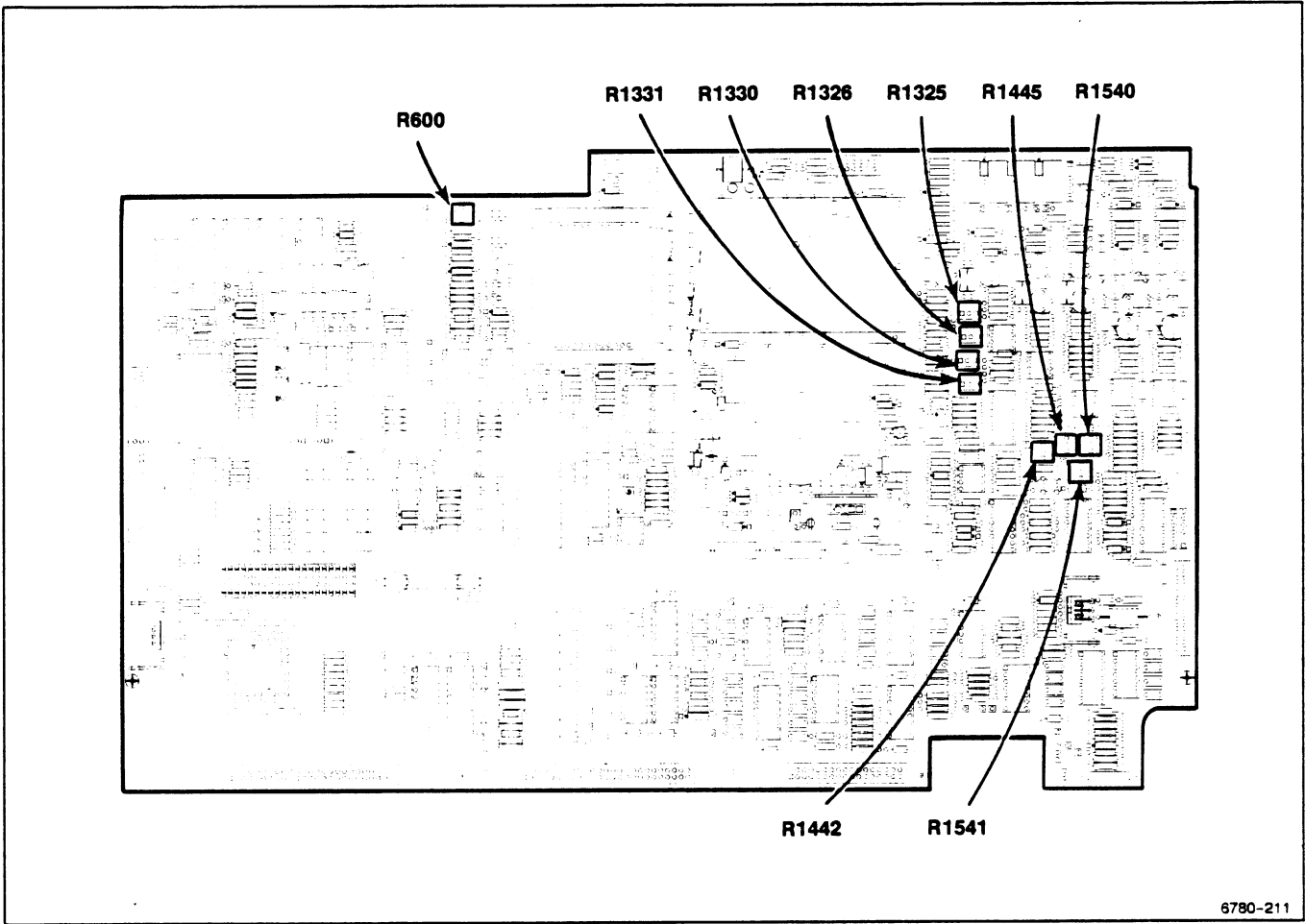
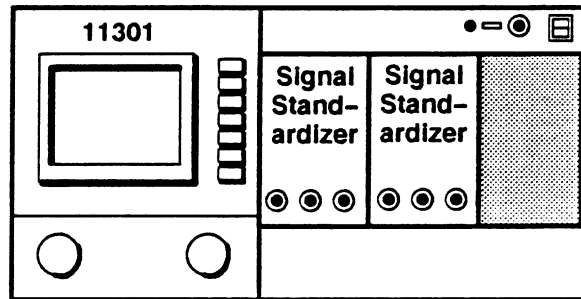

Figure 2-13. A13 Scope Logic board (Display Quality) adjustment locations.

## Y-Axis Alignment

### Setup



Initialize the oscilloscope's settings, then perform the following:

**Remove the top and bottom covers from the mainframe.**

**Left Signal Standardizer**

Not used in this step.

**Center Signal Standardizer**

Not used in this step.

### Procedure

- a. Adjust the front-panel INTENSITY knob to set the character (CHAR) intensity to a comfortable viewing level.
- b. Press the DISP ADJ button at the right of the screen. Touch the **Trace Rot(ation)** area on the screen.
- c. Carefully adjust the right knob so that the trace on the screen is parallel to the center horizontal graticule line. Press the DISP ADJ button again to exit from the menu.
- d. Press the CURSORS button below the screen and select **Horizontal Cursors**.
- e. Adjust the right knob so that the dashed cursor passes through the intersection of the center vertical and center horizontal graticule lines.
- f. **CHECK**—that the tilt of the cursor relative to the center vertical graticule line is less than 0.05 division (one quarter minor division) anywhere within the center six vertical divisions.



DO NOT attempt to adjust the y-axis alignment if the performance is within the tolerance specified. Proceed to the Display Clarity and Geometry Checks/Adjusts that follow.

- g. **ADJUST**—R1326 on the A13 Scope Logic board so that the dashed cursor aligns with the center vertical graticule line. Refer to Figure 2-13 for the location of this adjustment.

## Display Clarity and Geometry

### Setup

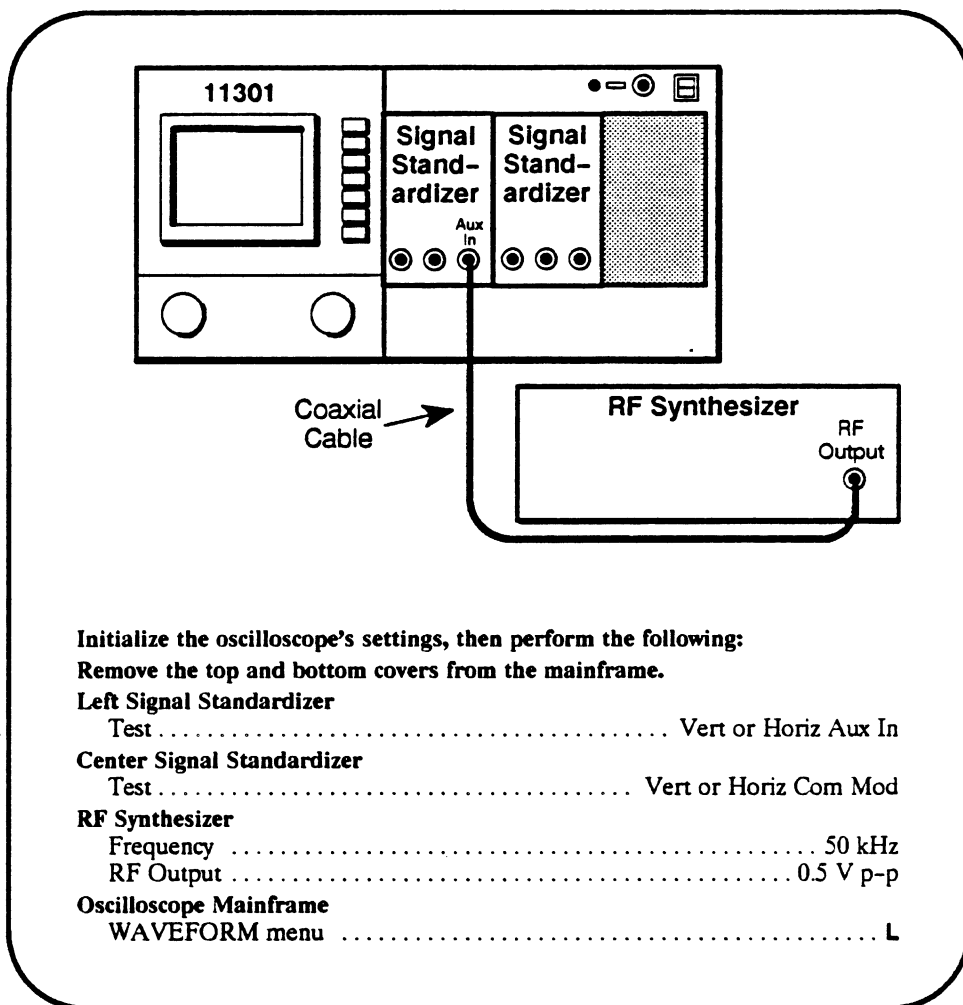

### Procedure

- a. Start the test `auto_vert` to align the crt beam to the graticule. If the readout cannot be properly aligned then the instrument gain must be adjusted before proceeding with the Display Quality checks. To correct the instrument gains perform the following in order:
  - Part 12 – Vertical Center
  - Part 13 – Magnified Registration
  - Part 15 – Plug-in Interface Gains
  - Part 19 – Beam Registration
 After running these procedure Parts perform the above Setup then proceed to step a.
- b. Adjust the MAIN and CHAR INTENSITY so that the sinewave and character displays are dim, but viewable.
- c. Adjust the Amplitude and Position knobs of the left Signal Standardizer for a centered display of 6.5 divisions in amplitude. Set the Horizontal Size to 50  $\mu$ s/div and adjust the trigger level (if necessary) for a stable display.

- d. Press the DISP ADJ button to the right of the screen.
- e. **ADJUST** – the **Trace Rot(ation)** so that the displayed horizontal line is parallel with the center horizontal graticule line.
- f. Touch the **Focus/Astig** label on the screen and select FINE increments for both the left and right knobs. Leave the display adjustment menu on screen.
- g. **ADJUST** – the front-panel **Focus** and **Astigmatism** using the left and right control knobs respectively, for the most uniform and sharpest sinewave display.
- h. **CHECK** – that the sinewave trace has reasonably uniform thickness (focus) across the screen. Observe both the tops and sides of the sinewave cycles. The trace thickness within the first division at the left edge of the screen and within the last division at the right edge of the screen may be somewhat larger.
- i. **CHECK** – that the characters displayed on the screen are legible. Do not expect all characters to have equally good focus, but all characters must be legible.
- j. Select **Pattern 1** for display on the screen.
- k. **CHECK** – that the graticule lines that are etched into the faceplate of the screen are either enclosed by or touching the pairs of lines that are displayed in the crosshatch pattern within the center 6 by 8 division area. Exclude the outer one-division width at the top, bottom and both sides of the display. The display pattern has three lines across the center vertical and center horizontal graticule lines. Ignore the center of these three lines for this evaluation.



DO NOT attempt to adjust the crt display if the performance is acceptable. The adjustment of the crt display is time consuming, with interacting adjustments. Proceed to the next procedure Part.

#### NOTE

*Before performing this adjustment you should optimize the Y-Axis Alignment, as described previously in this procedure Part.*

*The following adjustments may cause misalignment of the character display to the crt faceplate. Later adjustments correct this. Do not initiate the Enhanced Accuracy process unless instructed to do so in the procedure.*

- l. **ADJUST** – R1442 on the A13 Scope Logic board fully clockwise. Refer to Figure 2-13 for the location of this adjustment.
- m. **ADJUST** – R1541 on the A13 Scope Logic board fully counterclockwise. Refer to Figure 2-13 for the location of this adjustment.
- n. Select **Pattern 1** for a crosshatch display.
- o. **ADJUST** – the CHAR INTENSITY for a dim but viewable display. Reduce the MAIN INTENSITY so that the sinewave is not visible.

- p. Perform the adjustments in Table 2-2 to optimize the characteristics of the crosshatch display (listed in the left column).

**TABLE 2-2  
Crosshatch Display**

To adjust for:	Adjust the following:
The defocus of the vertical line pairs of the pattern so that they just touch.	Focus (left knob) Astigmatism (right knob)
The most uniform line width of the vertical lines from the top to the bottom, near the center of the screen.	R1445 (refer to Fig. 2-13 for the location of this adjustment)
The optimum clarity of the crosshatch display.	Focus (left knob) Astigmatism (right knob)
The best geometry within the center 6 x 8 divisions of the screen.	R1325 (refer to Fig. 2-13 for the location of this adjustment)
The best focus balance between the top and bottom edges of the screen. Especially check this for the set of three vertical lines in the center of the screen.	R1540 (refer to Fig. 2-13 for the location of this adjustment)

**NOTE**

*If the pattern is misaligned, then visually compensate for this shift when adjusting R1325.*

- q. Press the DISP ADJ menu button to remove the crosshatch pattern. Reduce the CHAR INTENSITY to that at which the characters are not viewable. Adjust the MAIN INTENSITY for a sinewave display that is dim but viewable.
- r. Perform the adjustments in Table 2-3 to optimize the characteristics of the sinewave display (listed in the left column).

**TABLE 2-3  
Sinewave Display**

To adjust for:	Adjust the following:
The optimum clarity of the sinewave display.	Focus (left knob) Astigmatism (right knob)

- s. **ADJUST**—the CHAR INTENSITY for a dim but viewable display. Reduce the MAIN INTENSITY so that the sinewave is not visible.
- t. Select the DISP ADJ menu by pressing the appropriate button at the right of the screen.

- u. When the DISP ADJ menu is displayed, there are two areas on the screen that have a highlighted background consisting of many dots. One highlighted area is in the top division of the screen, accenting the trace description, and the other is at the right edge of the screen, accenting the **Focus/Astig** label. These two areas are used to optimize the setting of R1540 as described in the next steps.
- v. You must balance the character definition at different areas of the screen. Give the characters in the top and bottom divisions somewhat higher importance since these areas of the screen very frequently have characters displayed.
- w. Perform the adjustment in Table 2-4 to optimize the characteristics of the character display (listed in the left column).

**TABLE 2-4**  
**Character Display**

To adjust for:	Adjust the following:
The best overall character focus.	R1442 (refer to the “RO” designation on the A13 Scope Logic board in Fig. 2-13 for the location of this adjustment)
The best character clarity at the left and right of the display.	R1541 (refer to Fig. 2-13 for the location of this adjustment)
The best definition of the dots in the two highlighted areas on screen.	R1331 (refer to Fig. 2-13 for the location of this adjustment)

- x. **ADJUST**—the CHAR intensity so that the character display on the screen is not visible. Increase the MAIN intensity for a dim but viewable display.
- y. Perform the adjustments in Table 2-5 to optimize the characteristics of the sinewave display (listed in the left column).

**TABLE 2-5**  
**Sinewave Display**

To adjust for:	Adjust the following:
The optimum clarity of the sinewave display.	<b>Focus</b> (left knob) <b>Astigmatism</b> (right knob)
The best compromise of focus from the top to the bottom and along the center horizontal graticule line. Especially check for this at one division from the left and right edges and at the center of the screen.	R1540 (refer to Fig. 2-13 for the location of this adjustment)

- z. The adjustment made in Table 2-5 may affect the adjustments made in Table X3 (that is, these adjustments interact). Therefore, with the display set for characters only, you need to perform the adjustments made in Table 2-4 again.

- aa. If these adjustments change the shift or size of the character or crosshatch pattern displays, then start the test `auto_vert` to align the crt beam to the graticule.

## High Drive Focus

### Setup

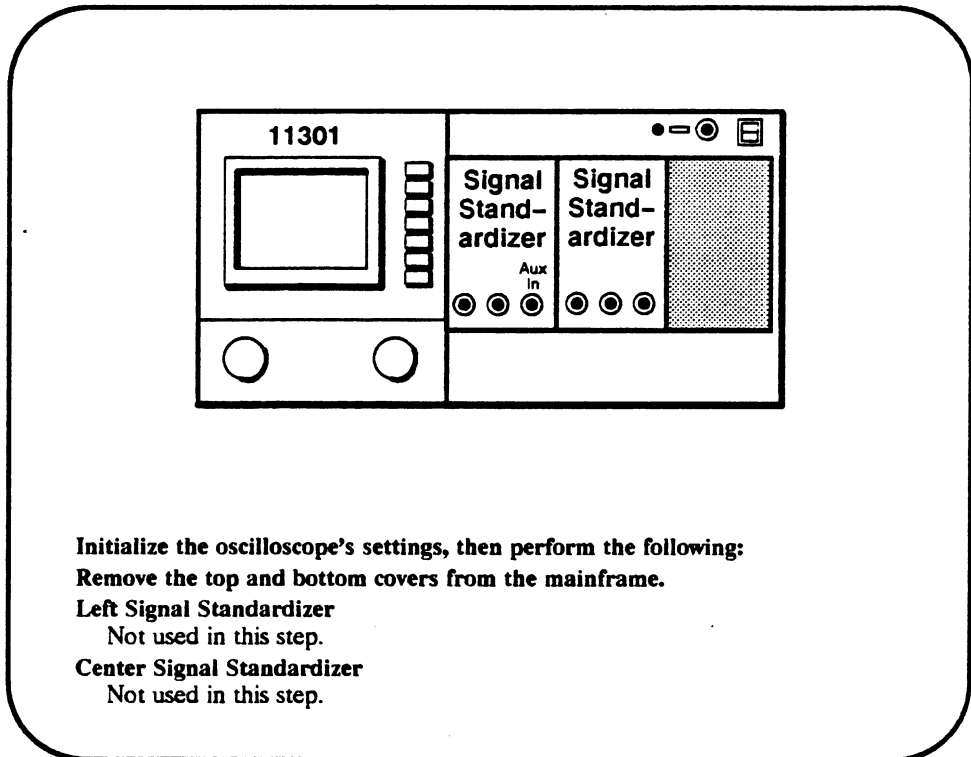

Initialize the oscilloscope's settings, then perform the following:  
 Remove the top and bottom covers from the mainframe.  
**Left Signal Standardizer**  
 Not used in this step.  
**Center Signal Standardizer**  
 Not used in this step.

### Procedure

- a. Press the DISP ADJ button at the right of the screen.
- b. Select **Pattern 1** for display on the screen.
- c. **ADJUST**—the front-panel INTENSITY control knob to set the CHAR intensity to its maximum value. The beeper sounds when the maximum value is reached.
- d. **CHECK**—the line widths of **Pattern 1** for reasonable uniformity over the entire screen and for uniformity of focus. (Note that it is normal for line width to increase with high intensity levels.)



**DO NOT** attempt to adjust the overall focus of the pattern if the performance of **Pattern 1** is reasonable. Proceed to the next part of the Checks and Adjustments.

- e. **ADJUST**—R600 on the A13 Scope Logic board for the best overall focus of the pattern (refer to Fig. 2-13 for the location of this adjustment).
- f. Reduce the INTENSITY to a normal level and press the WAVEFORM button to leave the Utility menu.



---

## Part 9 – Stored Waveform Vectors

---

### Description

This test checks the vector adjustment by displaying an XY waveform and checking it for trace separation as depicted in Figure 2-14.

### Setup

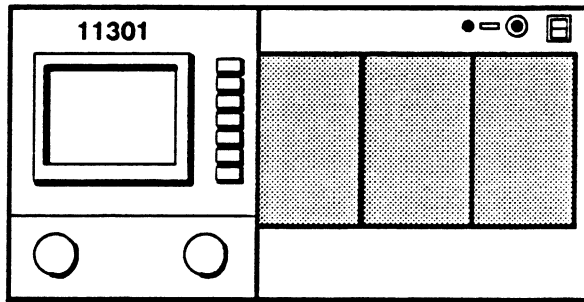

Remove the top and bottom covers from the mainframe.  
No plug-in units or connections are necessary.

### Procedure

- a. Start the `crt_vector` test. Follow the instructions given on the PC.



DO NOT adjust the vectors unless the verification fails.

- b. Follow adjustment instructions on the PC and refer to Figure 2-15 for adjustment locations.

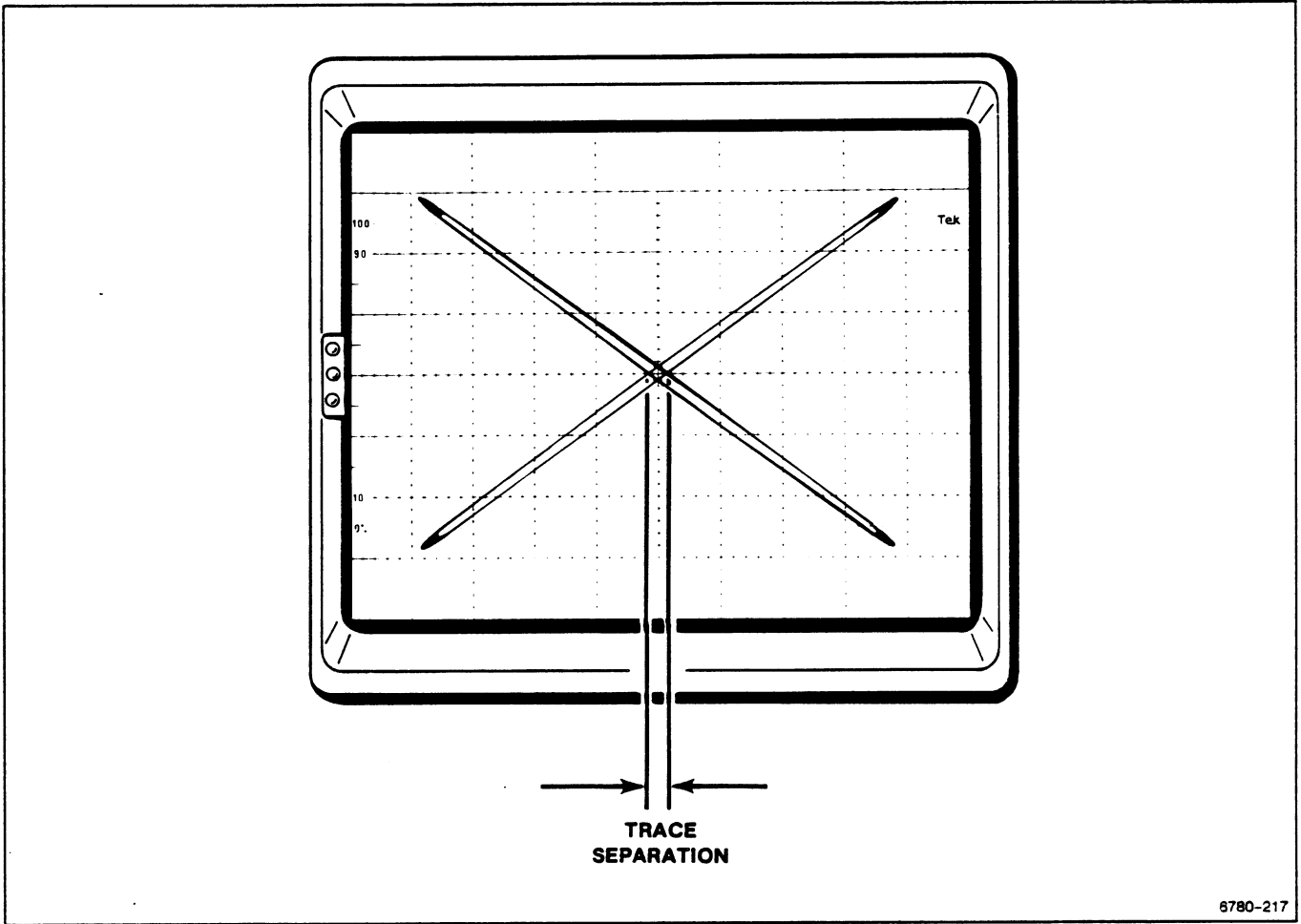

Figure 2-14. Trace separation measurement (0.2 div or less) on the displayed XY waveform.

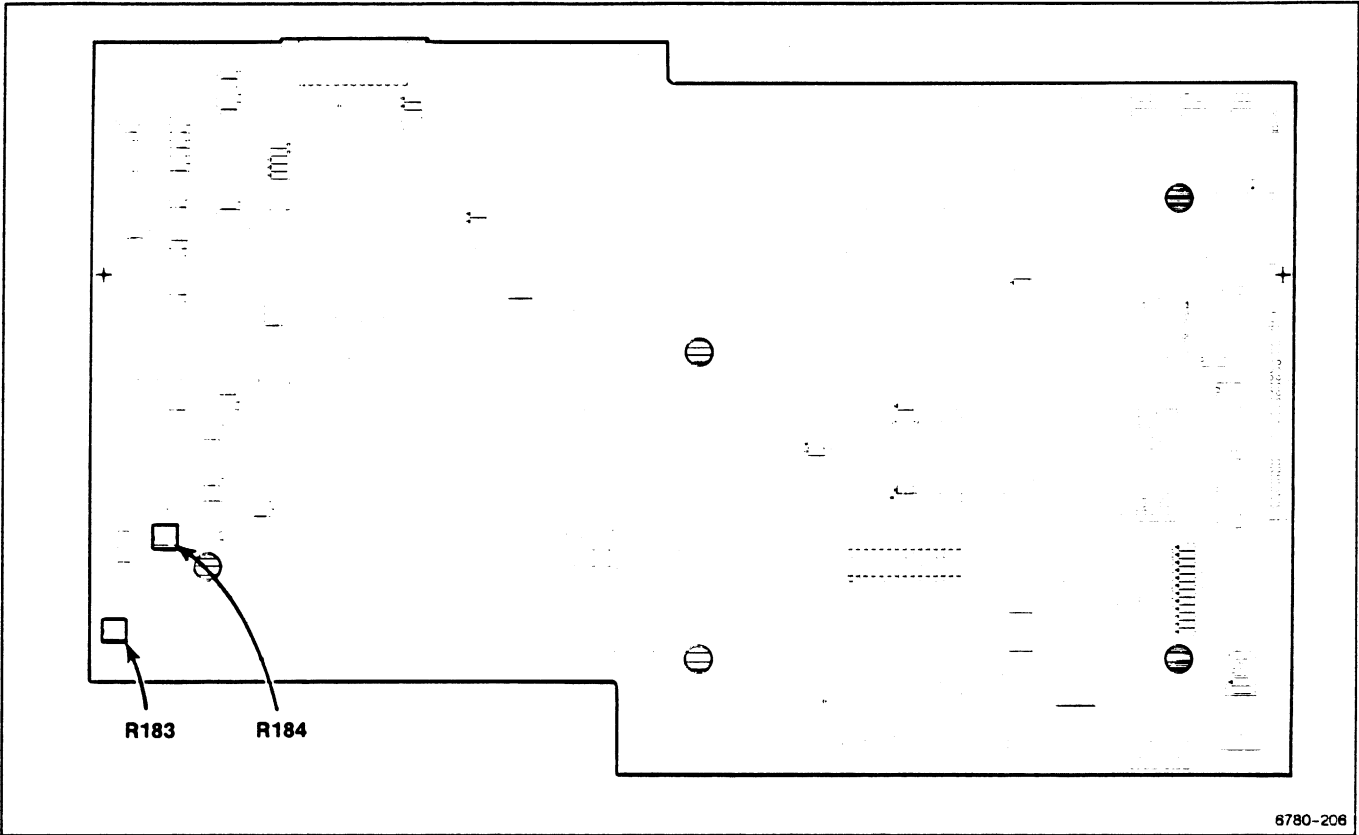

Figure 2-15. A11 Main Processor board (Stored Waveform Vectors) adjustment locations.

## Part 10 – Spot Shift

### Description

This test checks for excessive trace movement with changes in intensity.

### Setup

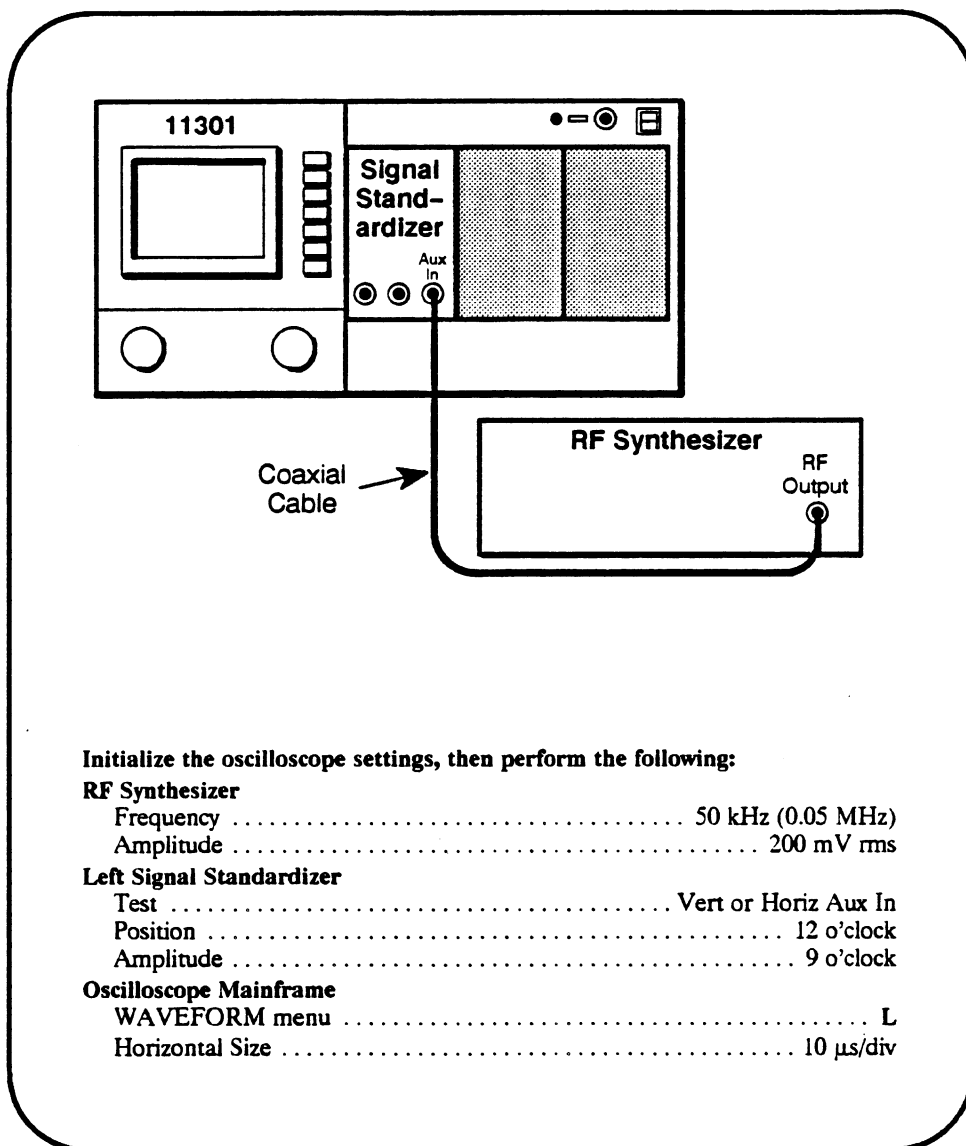

### Procedure

- Adjust the Signal Standardizer Position and Amplitude controls for a centered display of about six divisions.
- Press the HORIZONTAL DELAY button, then select **Window1 On**.
- Press the HORIZONTAL SIZE button and set the delayed sweep size to 500 ns/div.
- Select HORIZONTAL DELAY again and adjust the delay so that the intensified zone is near screen center on a falling edge of the sine wave.
- Press the DISP ADJ button, then select  $\Delta$ Main.

- 
- f. Adjust the right knob until the message “ $\Delta$ Main Intens = 100%” is displayed. Exit the menu by pressing the DISP ADJ button.

*Check Horizontal Shift*

- g. Briefly increase the MAIN INTENSITY to a high level and verify that the intensified zone remains symmetrical to the rest of the trace, even when the trace blooms. Some shift of the intensified zone may occur, but part of the intensified zone should remain where the trace was originally.
- h. Set the Main Horizontal Size to 1  $\mu$ s/div and the Delayed Horizontal Size to 200 ns/div.
- i. Adjust the Delay to put the intensified zone near the horizontal screen center.
- j. Adjust the Signal Standardizer Position control to put the intensified zone near the vertical center of the screen.

*Check Vertical Shift*

- k. Briefly increase the MAIN INTENSITY to a high level and check that the intensified zone remains symmetrical to the rest of the trace, even when blooming. Some shift of the intensified zone may occur, but part of the intensified zone should remain where the trace was originally.



DO NOT adjust the Spot Shift unless the verification failed.

## Spot Shift Adjustment

### Setup

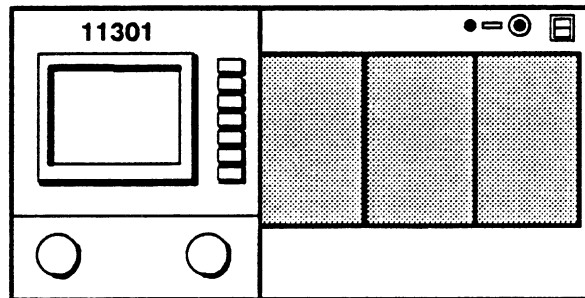

Remove the top and bottom covers from the mainframe.  
No plug-in units or connections are necessary.

### Procedure

**CAUTION**

*The spot shift test should be run quickly to avoid possible damage to the crt. DO NOT permit the test to run longer than 30 seconds.*

- a. Before starting the following PC test, find the adjustment locations on the circuit boards shown in Figure 2-16.
- b. Start the test `spot_shift`. Follow the instructions given on the PC.

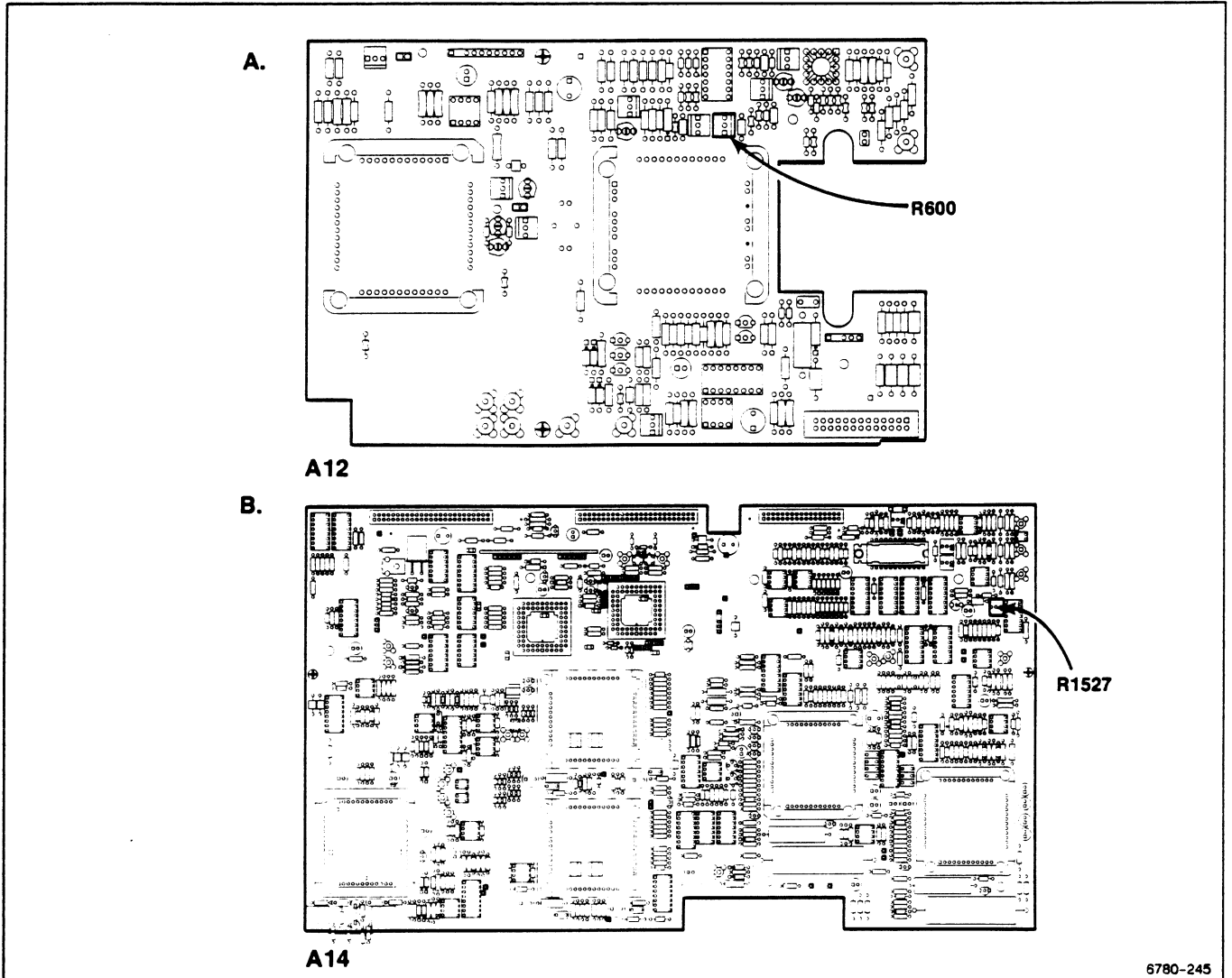

Figure 2-16. A12 Vertical board and A14 Timebase board (Spot Shift) test point and adjustment locations.

## Part 11 – Readout Jitter

### Description

This test checks the vertical stability while large vertical signals are present and the horizontal stability while using magnified sweeps.

### Vertical Readout Jitter

### Setup

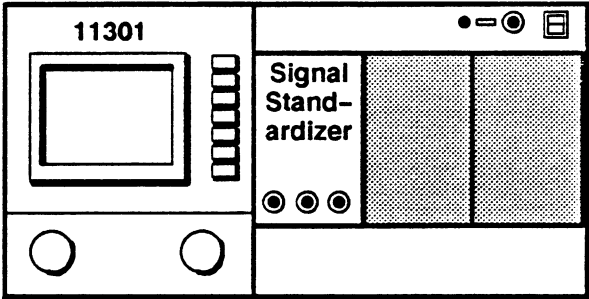

**Initialize the oscilloscope's settings then perform the following:**  
**Remove the top and bottom covers from the mainframe.**

**Left Signal Standardizer**

Test .....	Vert or Horiz, + Step
Position .....	12 o'clock
Amplitude .....	Fully counterclockwise (minimum)
Rep Rate .....	10 kHz

**Oscilloscope Mainframe**

WAVEFORM menu .....	L (left)
CURSOR menu .....	Vertical Cursors

### Procedure

- CHECK**—that a triggered squarewave signal is displayed. Adjust the MAIN INTENSITY and triggering if required.
- Set the Signal Standardizer Position and Amplitude controls to the fully clockwise position.
- CHECK**—the lower (dotted) cursor for stability and minimal vertical movement.



DO NOT start the following adjustment if the lower cursor was stable. Proceed to the next procedure Part.



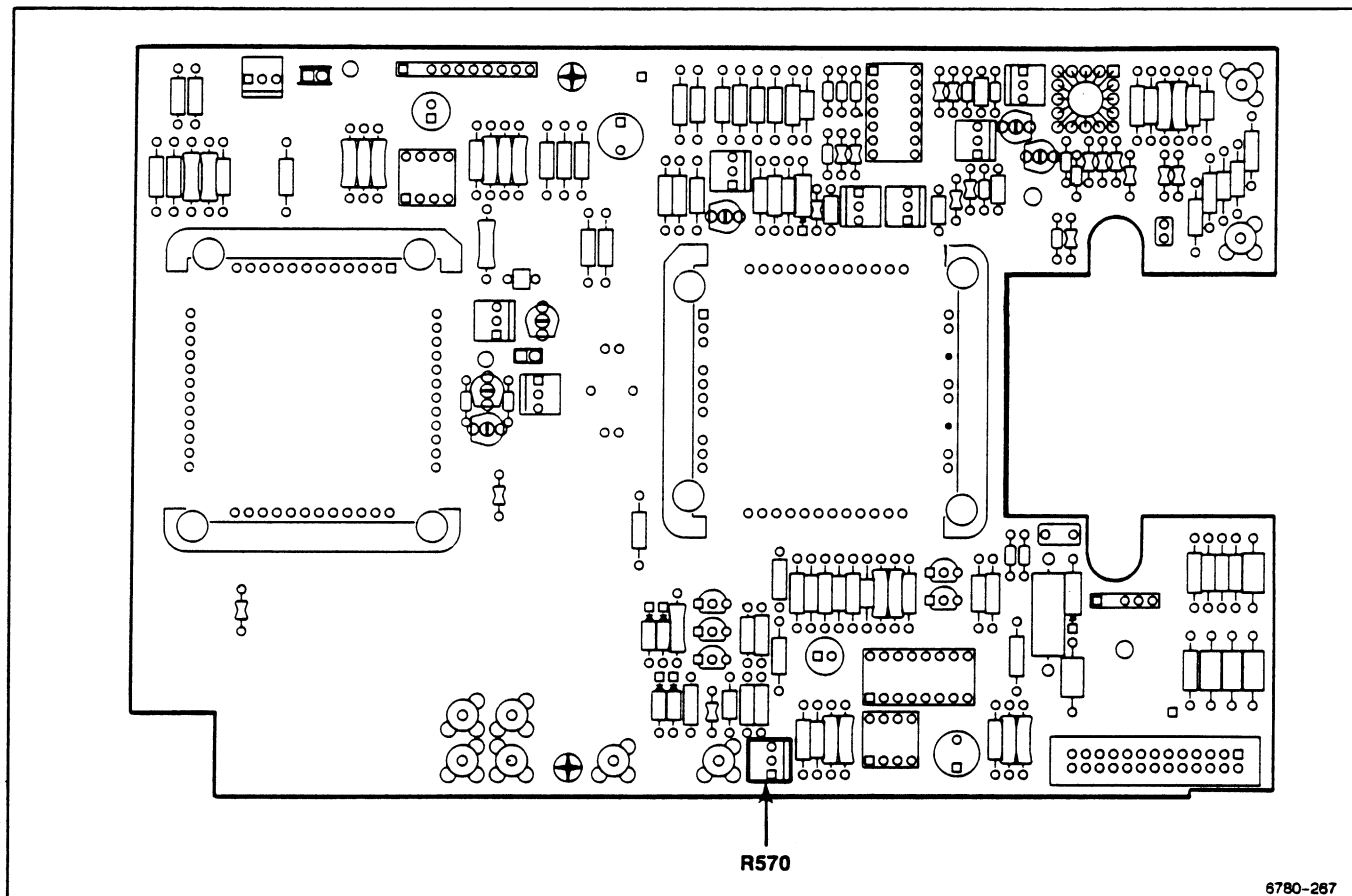

**Figure 2-17. A12 Vertical board (Vertical Readout Jitter) adjustment location.**

- e. **ADJUST**—R570 on the A12 Vertical board for minimum vertical movement of the lower, dotted cursor. Refer to Figure 2-17 for the adjustment location.
- f. Replace the carrying handle. This is the only adjustment, except Vertical High Frequency Response, for which the handle must be removed.

# Horizontal Readout Jitter

## Setup

**Initialize the oscilloscope's settings then perform the following:  
Remove the top and bottom covers from the mainframe.**

**Left Signal Standardizer**

Test .....	+ Step
Position .....	1 o'clock
Amplitude .....	9 o'clock
Rep Rate .....	1 kHz

**Oscilloscope Mainframe**

WAVEFORM menu .....	L (left)
Horizontal Size .....	5 ms/div
CURSOR menu .....	Horiz Cursors

## Procedure

- a. **CHECK**—that a triggered waveform is displayed. Adjust the MAIN INTENSITY and triggering if required.
  - b. Adjust the Signal Standardizer Position and Amplitude controls for a centered waveform with 5–6 divisions of amplitude.
  - c. Set 10X Mag to On (Horizontal Size menu) which results in a Horizontal Size of 500  $\mu$ s/div.
  - d. **CHECK**—the cursors for stability and minimal horizontal movement.
-  DO NOT start the following adjustment if the cursors appeared stable. Proceed to the next procedure Part.
- e. **ADJUST**—R1302 on the A14 Timebase board for minimum horizontal movement of the cursors. Refer to Figure 2-18 for the adjustment location.

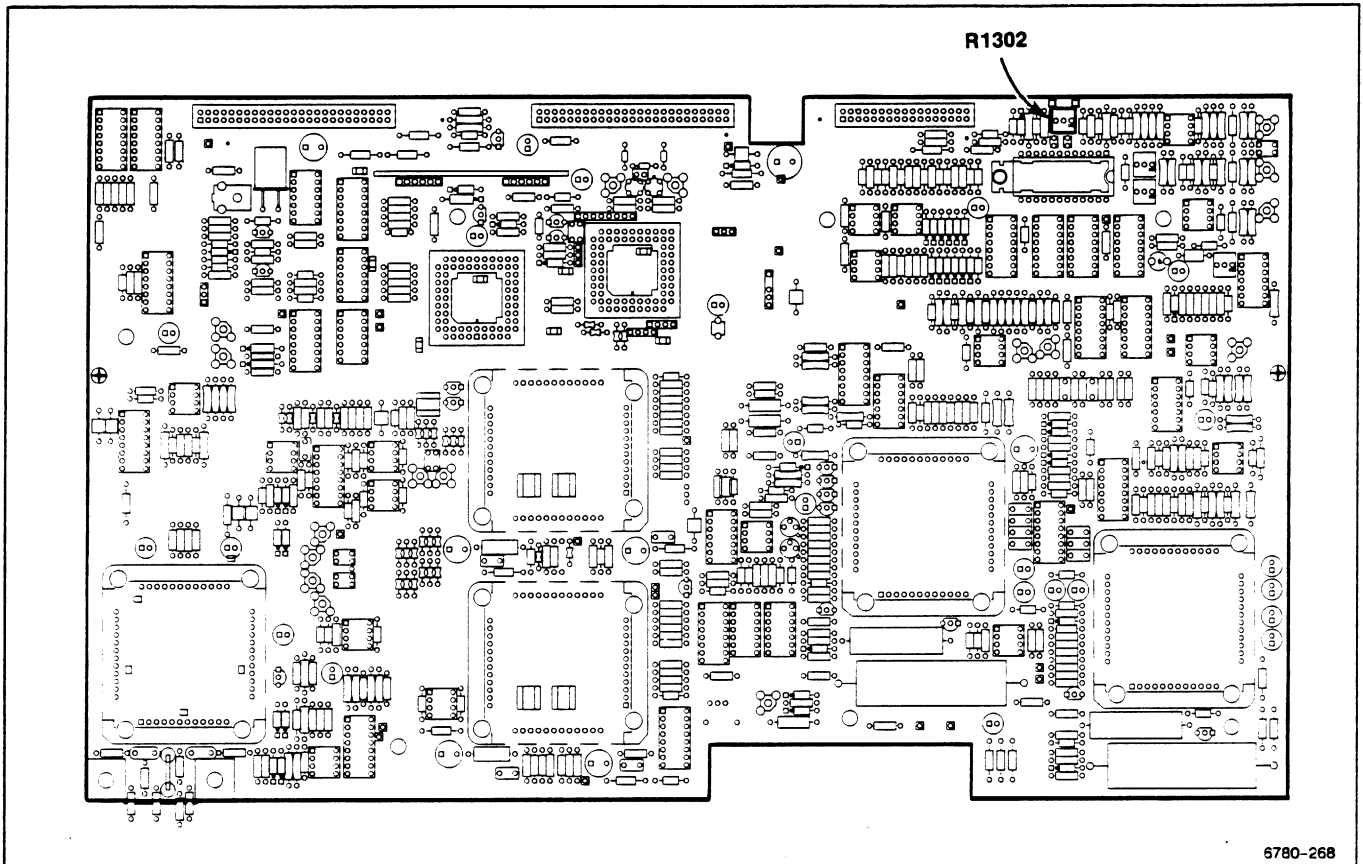

Figure 2-18. A14 Timebase board (Horizontal Readout Jitter) adjustment location.

---

## Part 12 – Vertical Center

---

**Description** This procedure balances the output stage of the vertical amplifier.

**Specifications** CRT display within  $\pm 0.2$  division of the center of the screen.

### Setup

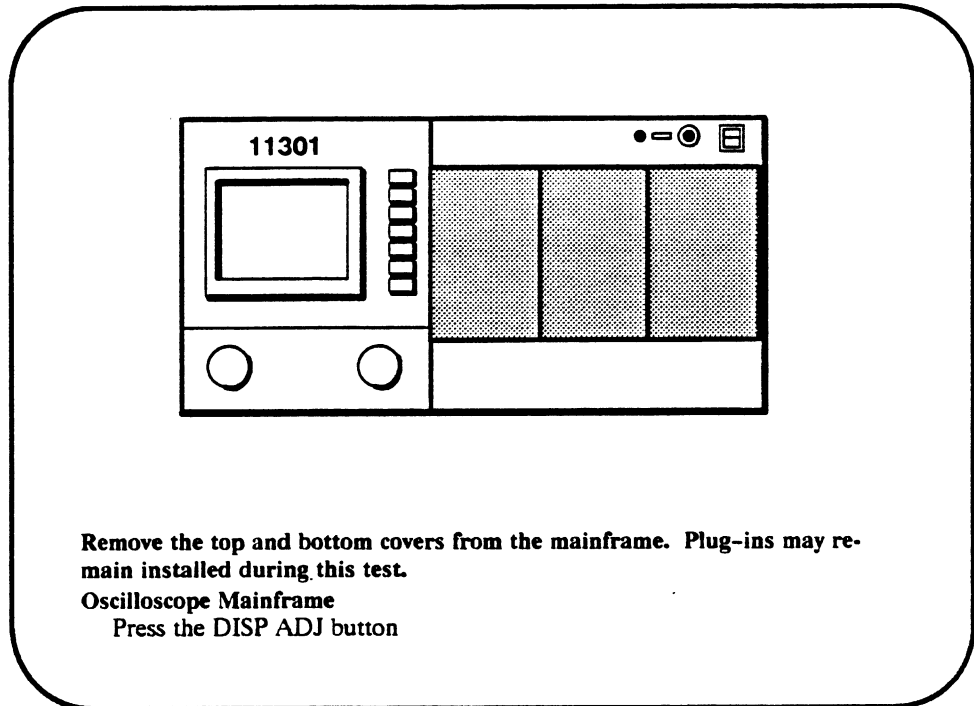

### Procedure

- a. On the A12 Vertical board, short the solder joints of the delay line DL200 together with the blade of a small screwdriver. Refer to Figure 2-19 for the shorting location.
- b. **CHECK**—that the display on the screen has collapsed into a single horizontal trace, and that this trace is within  $\pm 0.2$  division of the center of the screen.
  -  DO NOT attempt to adjust the vertical balance if it is within the stated limits. Proceed to the next procedure Part.
- c. **ADJUST**—R610 on the A12 Vertical board to vertically position the trace (with DL200 shorted) to within  $\pm 0.05$  division of the center of the screen. Refer to Figure 2-19 for the adjustment location.

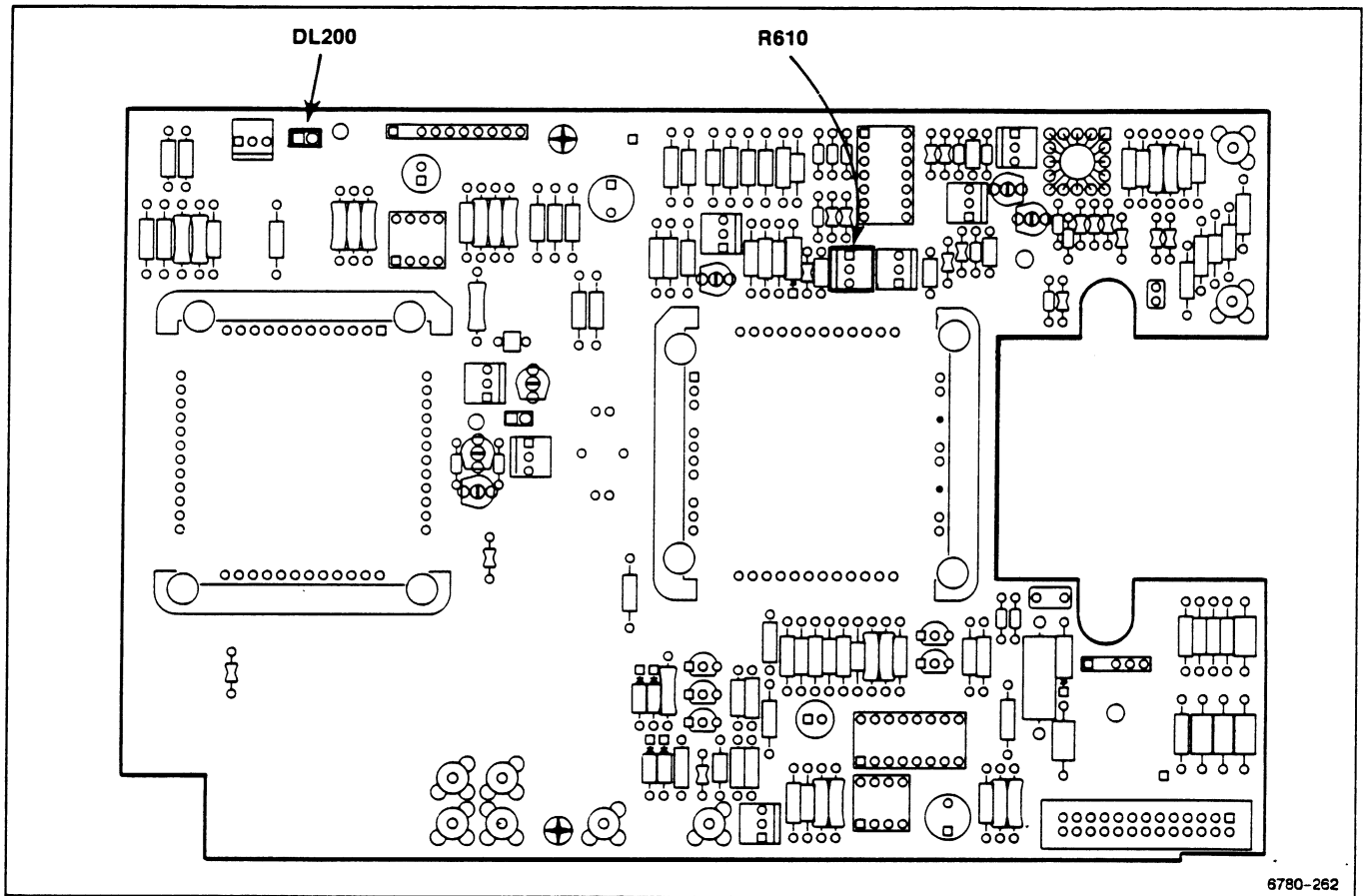

Figure 2-19. A12 Vertical board (Vertical Center) adjustment and shorting locations.

---

## Part 13 – Magnified Registration

---

### Description

This test checks for shifts in position of a waveform when switching between unmagnified and 10X magnified modes.

### Specifications

A waveform pulse at center screen should shift horizontally no more than 0.4 divisions when switching from 10X to 1X magnification.

### Setup

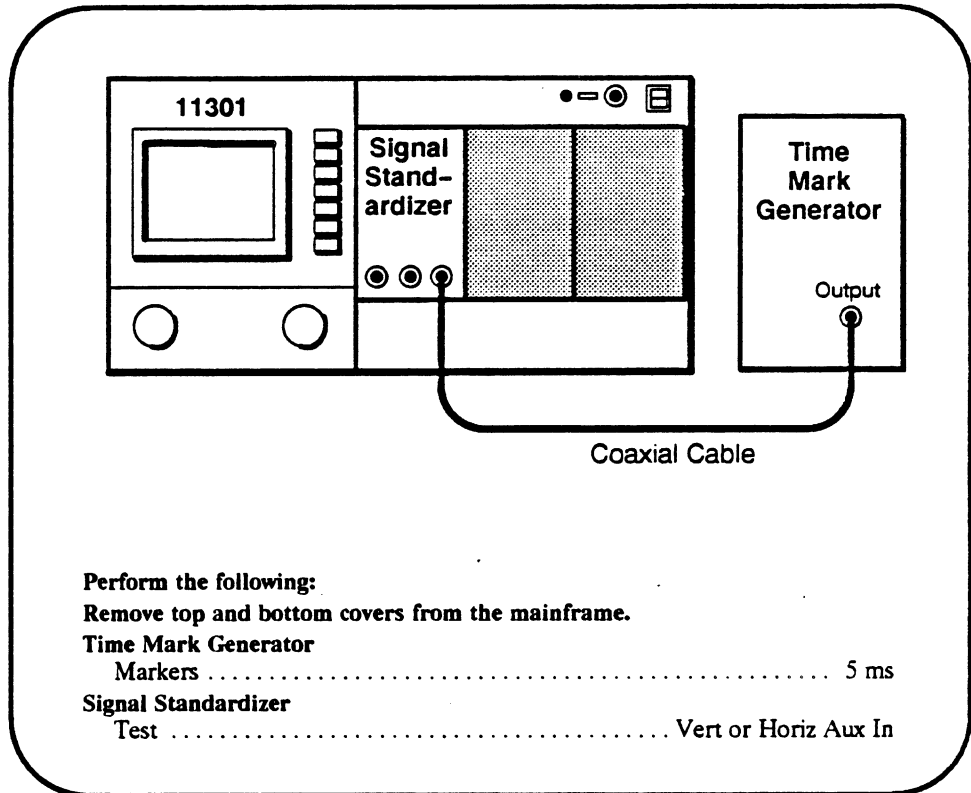

### Procedure

- During this test you will be asked to center a pulse horizontally on the screen. When positioning the waveform pulse, use the tip of the pulse as the waveform reference point.
- Start the test `hor_mag_reg` and follow the PC instructions. If adjustment is necessary, see Figure 2-20 for the adjustment location.



**DO NOT** adjust the registration unless the verification failed

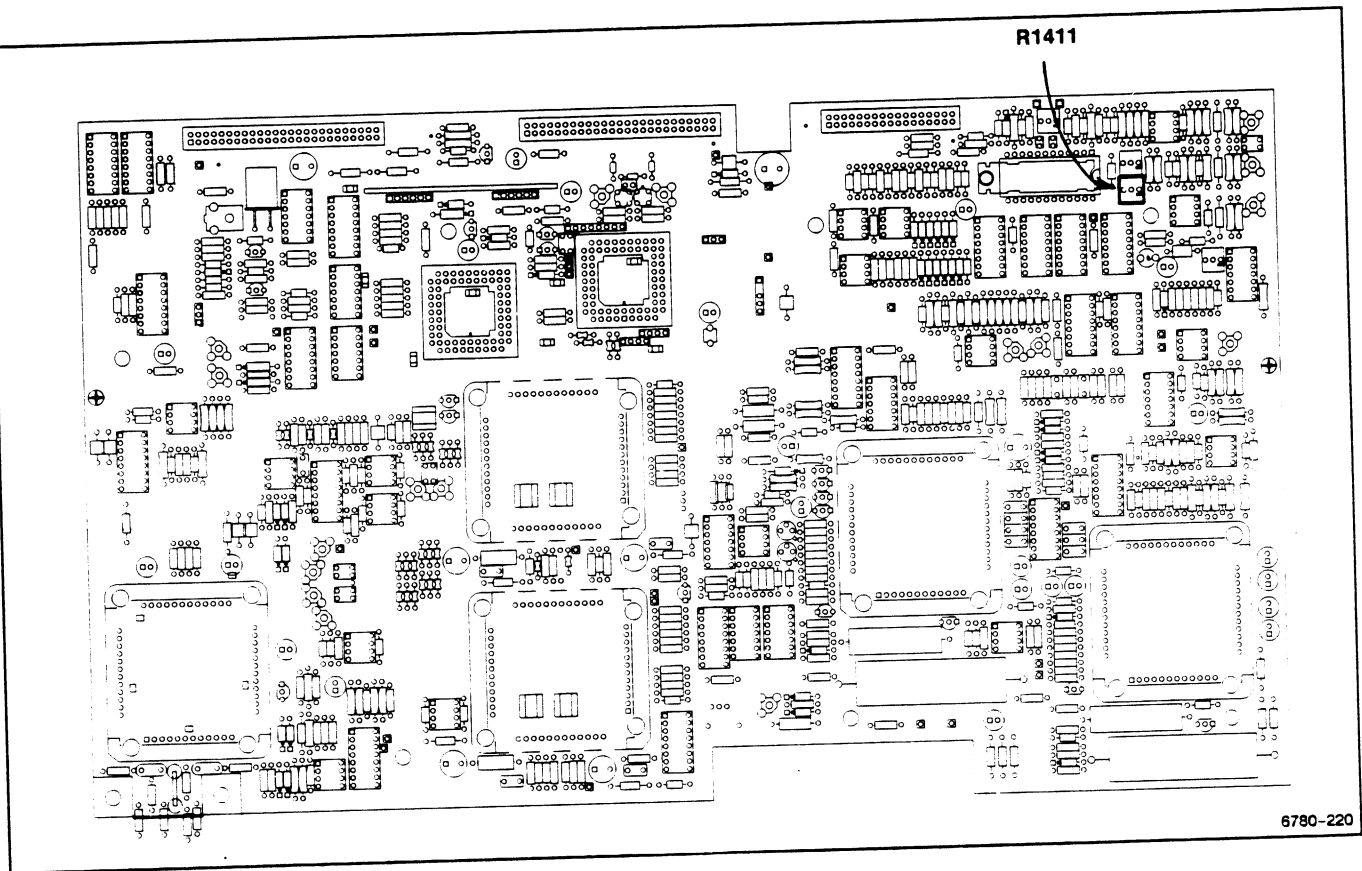

Figure 2-20. A14 Timebase board (Magnified Registration) adjustment location.

# Part 14 – XY Phase

## Description

This test checks a displayed XY trace for any phase shift.

## Specifications

For frequencies up to 1 MHz the phase difference is less than  $1^\circ$ . For frequencies from 1 MHz to 2 MHz the phase shift is less than  $3^\circ$ .

## Setup

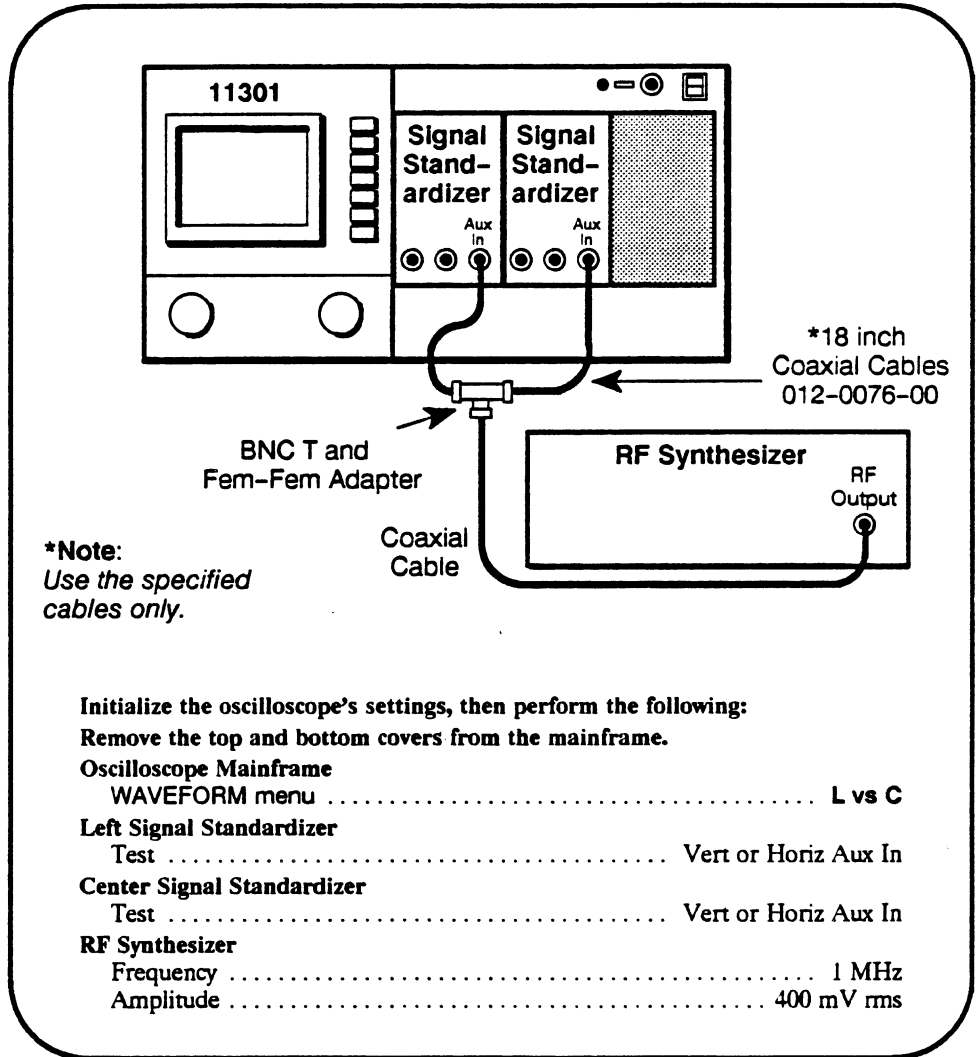

## Procedure

- Increase the XY INTENSITY until the XY waveform is visible.
- Adjust the Position and Amplitude controls of the left and center Signal Standardizers so that the trace is centered and is eight divisions wide and six divisions high. The Left plug-in controls the vertical while the center plug-in unit controls the horizontal.
- CHECK** – that the dimension A (see Figure 2-21) vertical amplitude  $< 0.1$  division.



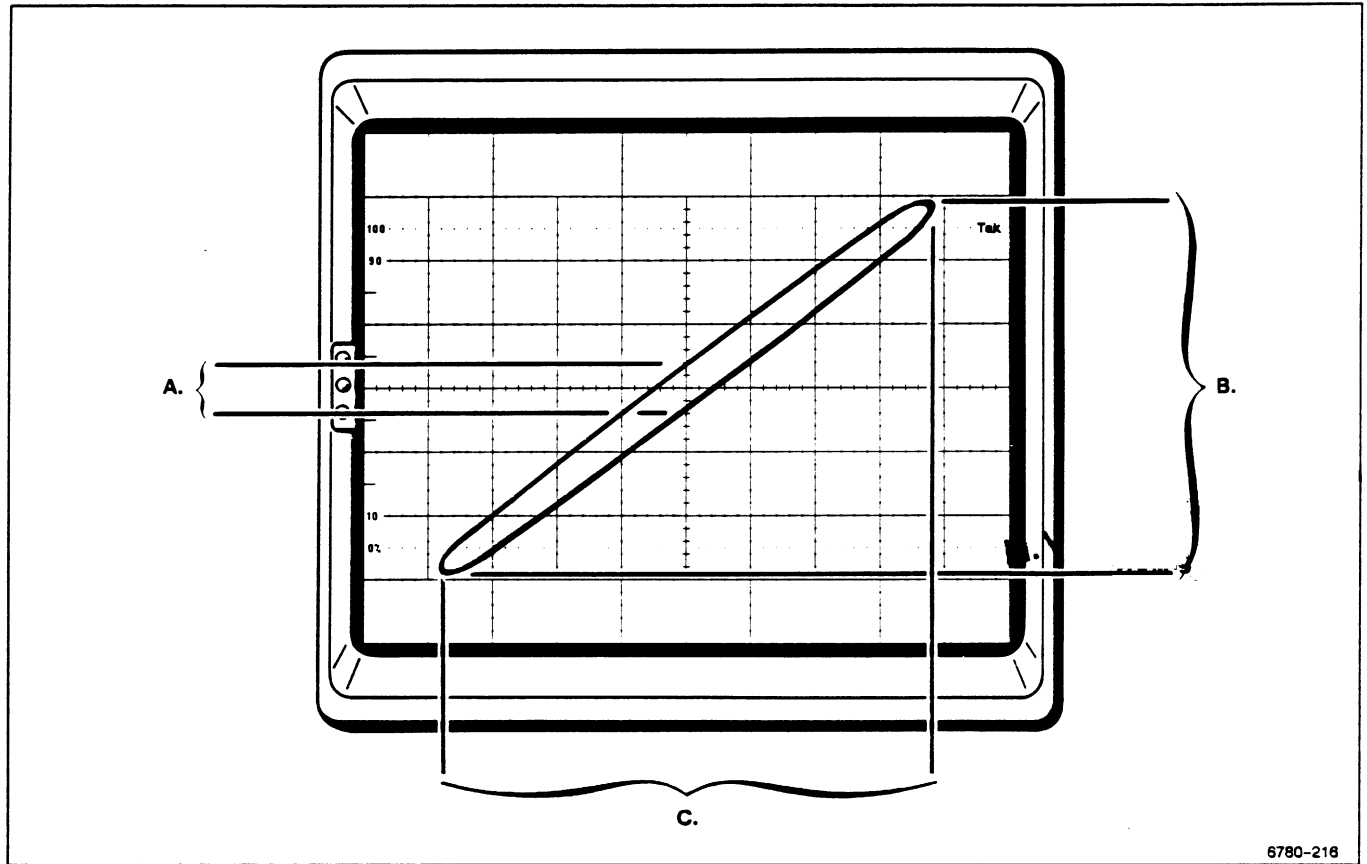

Figure 2-21. An XY waveform display showing dimensions A, B, and C. The actual phase difference is equal to  $\sin^{-1}(A \div B)$ .

- d. **CHECK** – that the dimension A vertical amplitude is  $< 0.31$  division as the frequency is adjusted from 1 MHz to 2 MHz in 100 kHz steps.
- e. **CHECK** – that dimension C is  $\geq 5.65$  divisions as the frequency is changed from 2 MHz to 3 MHz in 100 kHz steps.



DO NOT adjust the vertical amplitude of dimension A if it is within the stated limits. Proceed to the next procedure Part.

- f. Set the RF Synthesizer frequency to 1 MHz.
- g. **ADJUST** – the C1421 adjustment on the A14 Timebase board to minimize dimension A. Refer to Figure 2-22 for the adjustment location.

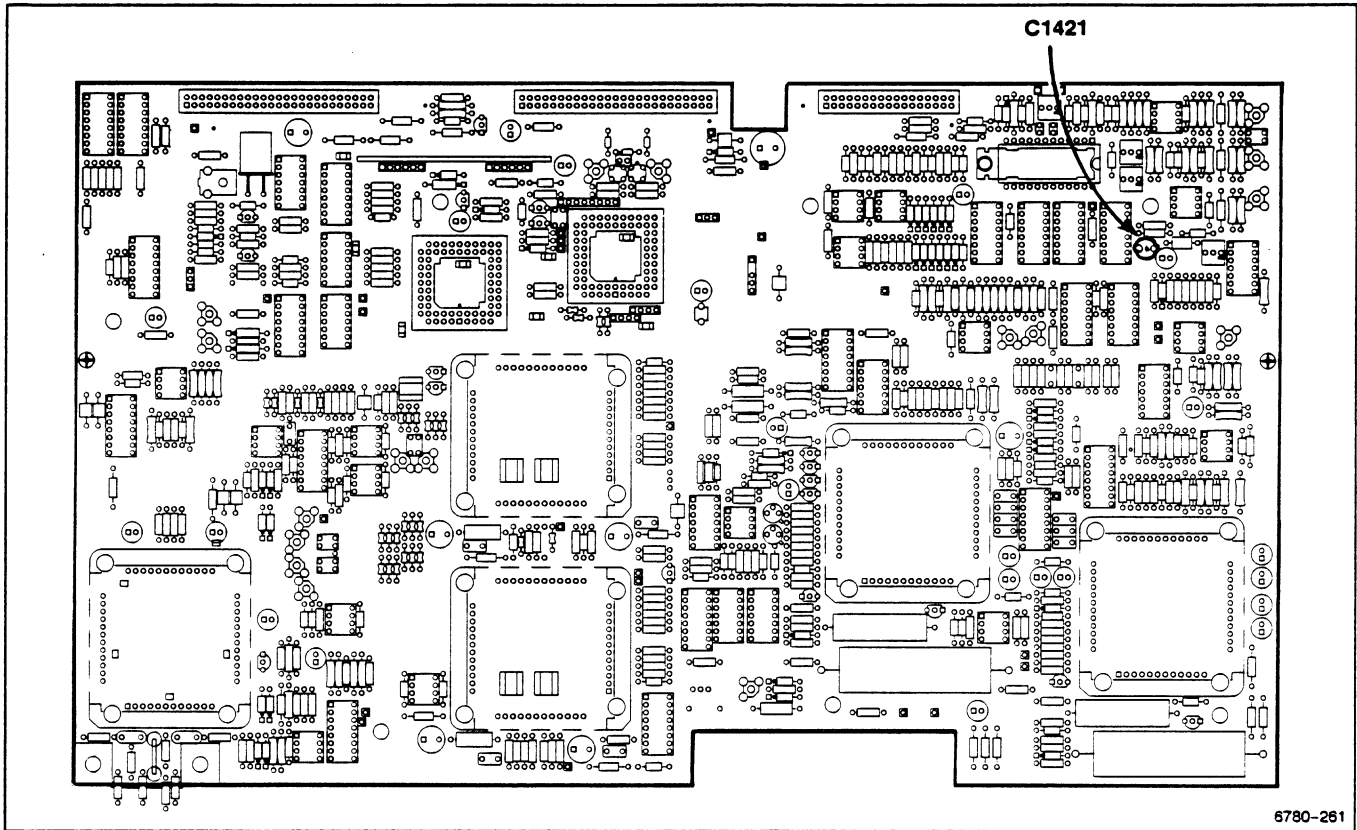

Figure 2-22. A14 Timebase board (XY Phase) adjustment location.

# Part 15 – Plug-in Interface Gains

## Description

This test verifies the Vertical Gain setting for the LEFT and CENTER compartments and the X Axis Gain settings for the CENTER and RIGHT compartments.

## Vertical Gain

### Setup

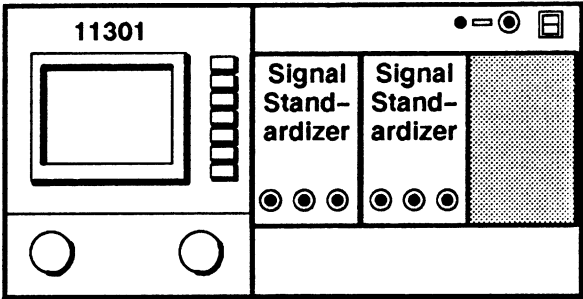

The diagram shows a control panel for a 11301 device. On the left is a screen labeled '11301' with a vertical scale to its right. Below the screen are two circular buttons. On the right side of the panel are two compartments labeled 'Signal Standardizer'. Each compartment has three small circular indicators below it. A shaded rectangular area is located to the right of the second 'Signal Standardizer' compartment.

**Perform the following:**

**Left Signal Standardizer**

Test ..... Vert or Horiz Gain

Rep Rate ..... 10 kHz

**Center Signal Standardizer**

Test ..... Vert or Horiz Gain

Rep Rate ..... 10 kHz

### Procedure

- a. Start the `vert_gain` test. Follow the instructions given on the PC.



**DO NOT** adjust the Vertical Gain unless the verification indicates that adjustment is necessary.



*DO NOT run Enhanced Accuracy if you made an adjustment during this test. Part 19 – Beam Registration must be performed before Enhanced Accuracy is invoked. Calibration constant information will be lost if this caution is ignored.*

# Horizontal XY Gain

## Setup

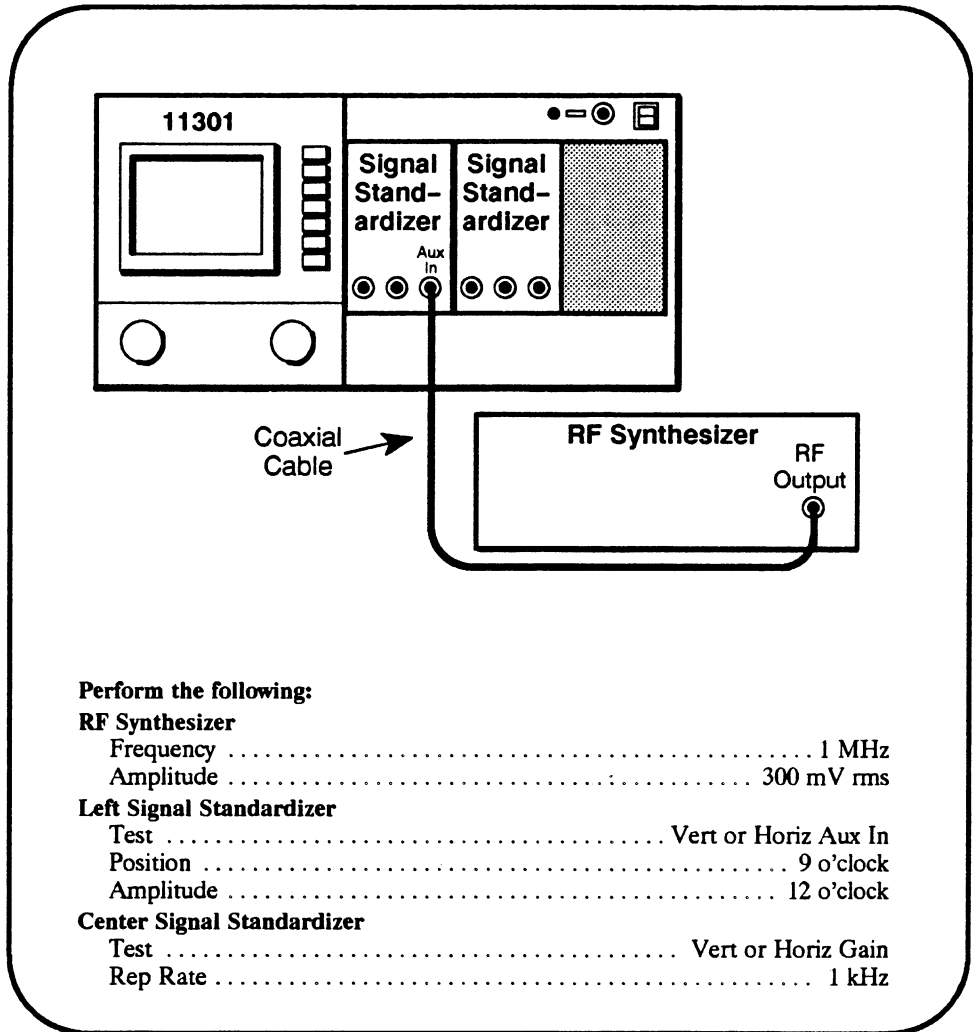

## Procedure

### NOTE

*You will need to adjust the MAIN and XY INTENSITY to view some traces during this test.*

- a. Start the hor\_gain test. Follow the instructions given on the PC.



**DO NOT** adjust the Horizontal Gain unless the verification indicates that adjustment is necessary.

---

## Part 16 – Vertical Center (Second Pass)

---

**Description** This procedure balances the output stage of the vertical amplifier.

**Specifications** CRT display within  $\pm 0.2$  division of the center of the screen.

### Setup

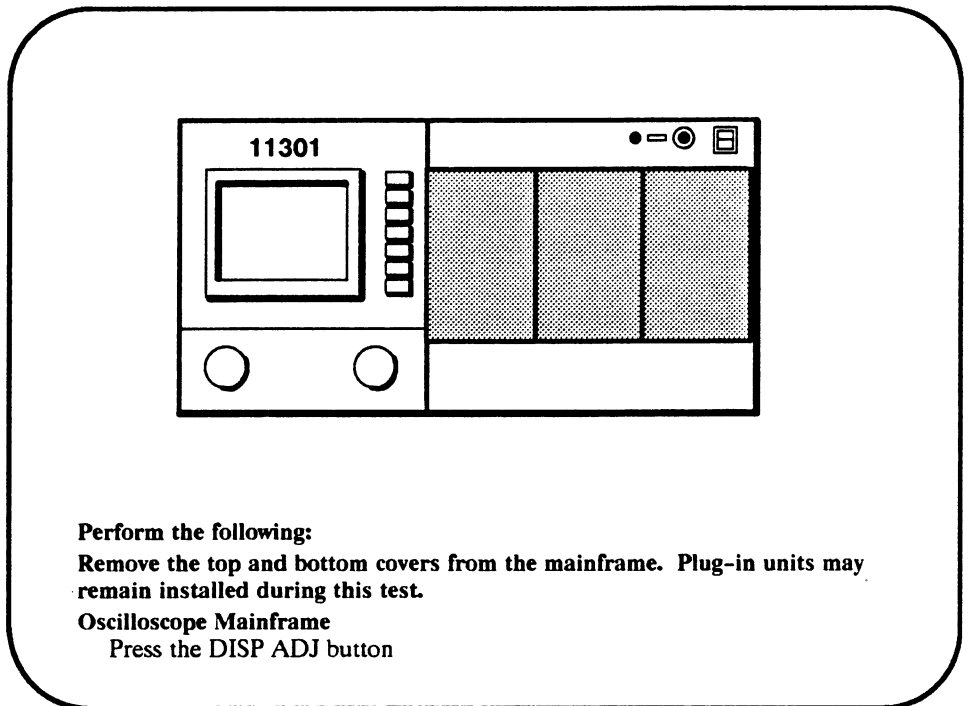

### Procedure

- a. On the A12 Vertical board, short the solder joints of the delay line DL200 together with the blade of a small screwdriver. Refer to Figure 2-23 for the shorting location.
- b. **CHECK** – that the display on the screen has collapsed into a single horizontal trace, and that this trace is within  $\pm 0.2$  division of the center of the screen.  
 DO NOT attempt to adjust the vertical balance if it is within the stated limits. Proceed to the next procedure Part.
- c. **ADJUST** – R610 on the A12 Vertical board to vertically position the trace (with DL200 shorted) to within  $\pm 0.05$  division of the center of the screen. Refer to Figure 2-23 for the adjustment location.

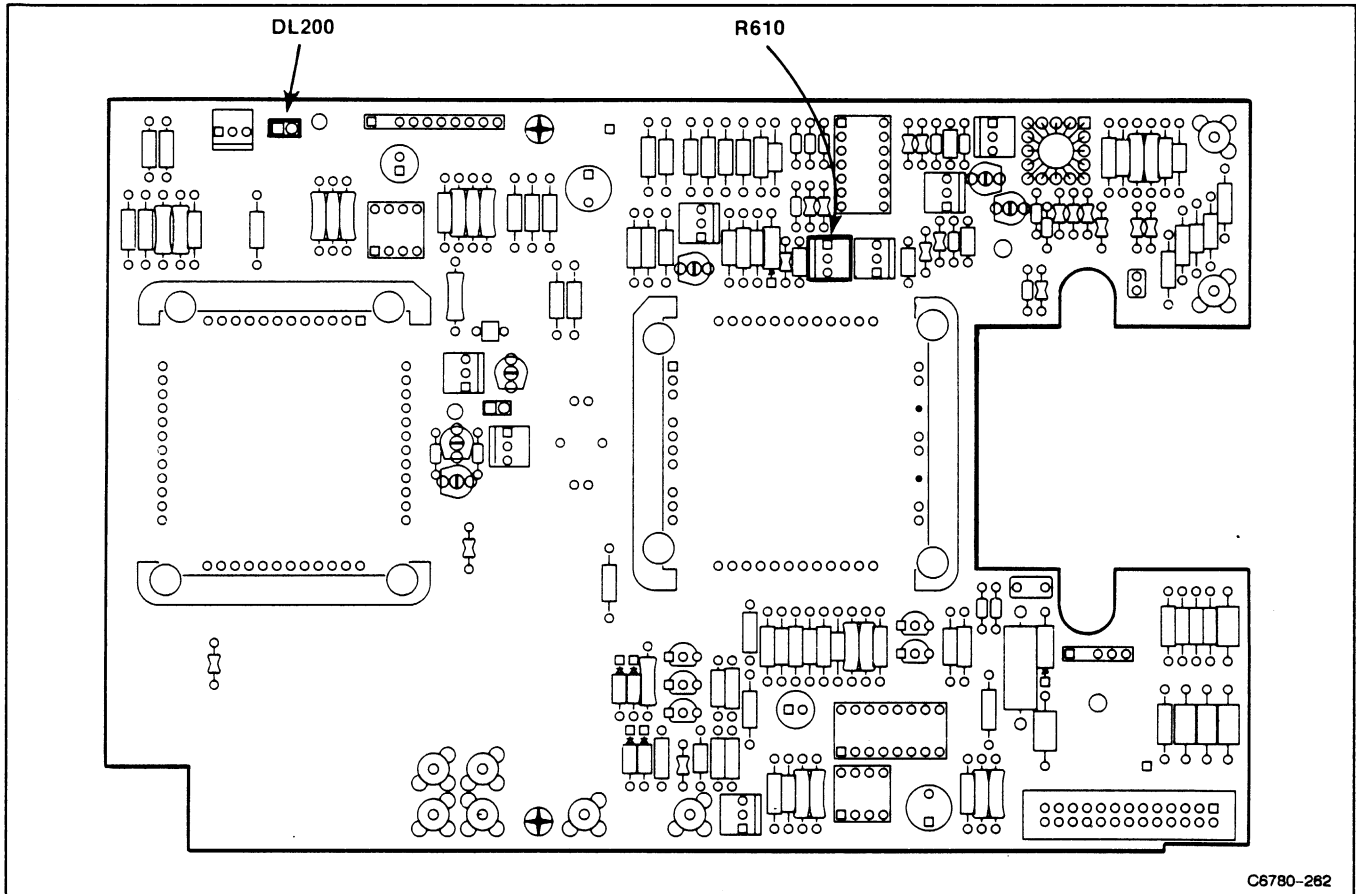

Figure 2-23. A12 Vertical board adjustment and shorting locations.

---

## Part 17 – Sweep Slew Rate Selfcal

---

### Description

This test automatically adjusts the sweep slew rate.

### Setup

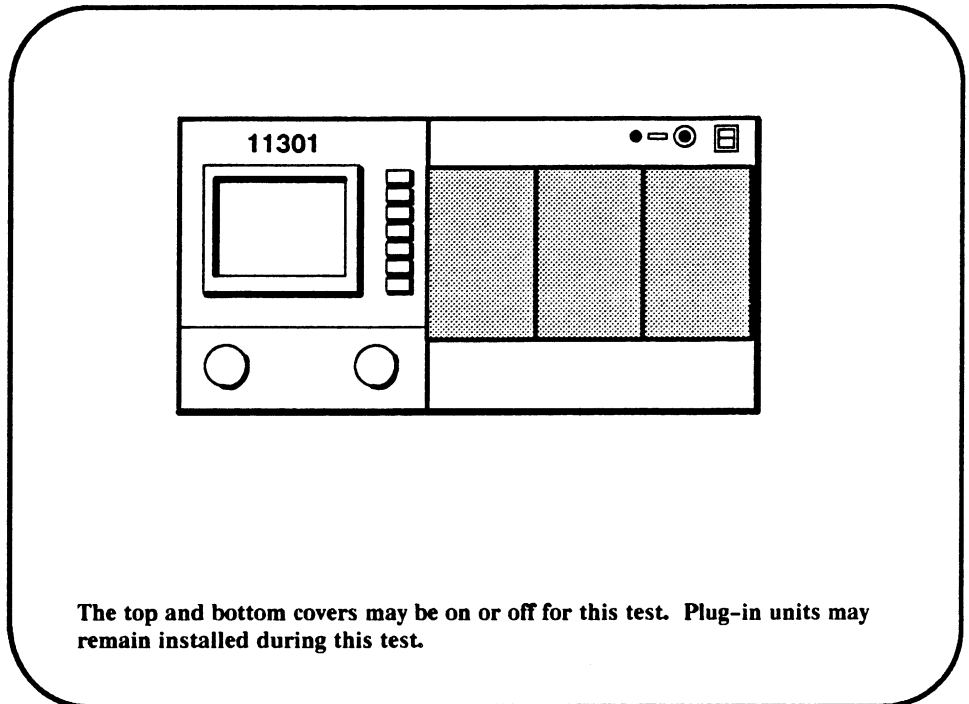

### Procedure

- a. Start the test `autocal_sweeps`. Follow the instructions given on the PC.

# Part 18 – Sweep Gains

## Description

This test checks the horizontal sweep timing, then, if necessary, allows adjustment with another test.

## Setup

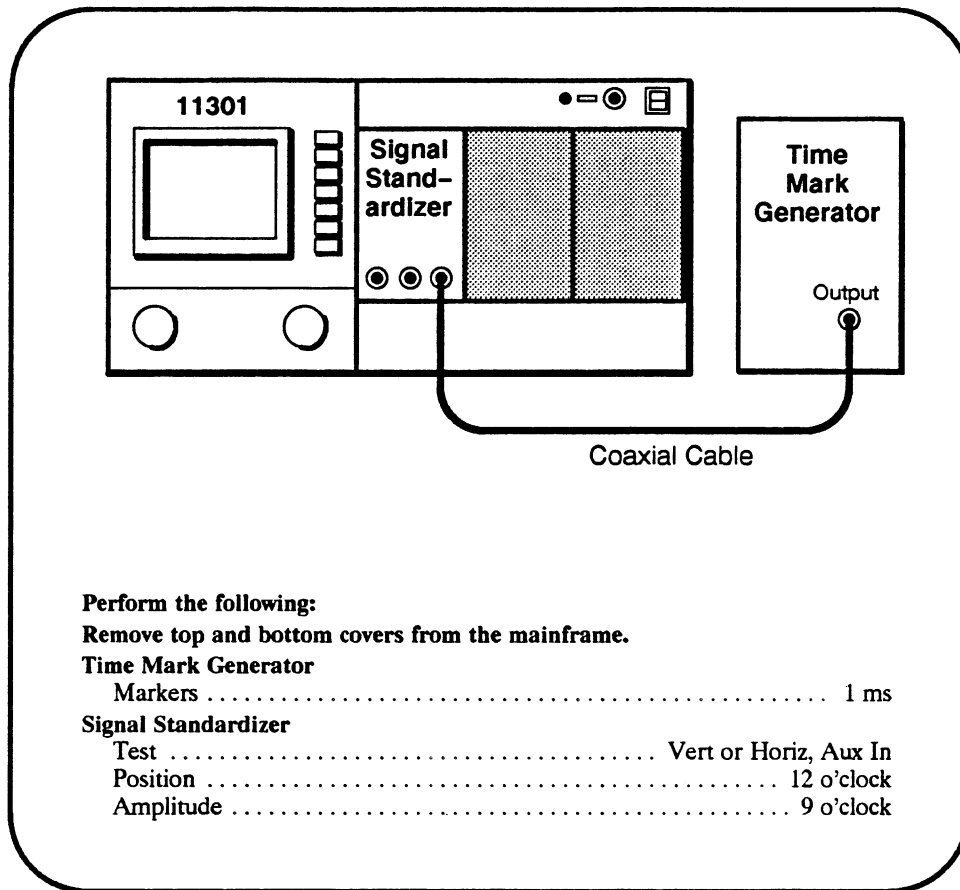

## Procedure

- a. The **sweep\_timing\_acc** test requires you to use the horizontal cursors to check the timing at different time/division settings for the Main and Delayed timebases. At each time/division setting the PC will prompt you to place the cursors at two waveform crossings of the center horizontal graticule line such that the cursors bracket one or more complete cycles. The PC will prompt you to enter the number of complete cycles between the cursors. Timing accuracy should be checked within the center eight horizontal divisions.
- b. Start the **sweep\_timing\_acc** test and run the 1 ms and 100  $\mu$ s Main (M) and Delayed (D) tests ONLY.
- c. When the first waveform appears adjust the Signal Standardizer Amplitude and Position Controls to obtain a centered four division trace.



- d. Examine the accuracy of the results for each time/div checked. After the four tests have run select Exit test. If the error exceeded 1/2 the allowed error for any of the four times/div, perform the adjustments described below.



DO NOT perform the following adjustment unless one of the checked sweep timing settings deviated by 1/2 the allowed error.

- e. Set the Time Mark Generator for 1 ms markers and the Signal Standardizer Test switch to Vert or Horiz, Aux In.
- f. Start the **sweep\_gain** test, then adjust the Signal Standardizer Amplitude and Position controls for a 6 div signal.
- g. Follow the instructions given on the PC. When the test finishes, proceed directly to the next procedure Part, Beam Registration. The calibration information derived during the **sweep\_gain** test is permanently stored when Beam Registration is performed.



*DO NOT run Enhanced Accuracy if you made an adjustment during this test. Part 19 – Beam Registration must be performed before Enhanced Accuracy is invoked. Calibration constant information will be lost if this caution is ignored.*

## Part 19 – Beam Registration

### Description

This test checks the beam registration signal for high-frequency noise, the beam registration system for proper light-induced bias of the photodetectors, and the graticule-to-display beam alignment.

DO NOT run this test unless you made an adjustment in one of the following procedure Parts:

Part 4 – CVR Accuracy	Part 12 – Vertical Center
Part 5 – A to D Converter	Part 13 – Magnified Registration
Part 6 – ACVS Gain	Part 15 – Plug-in Interface Gains
Part 8 – Display Quality	Part 16 – Vertical Center (Second Pass)
Part 10 – Spot Shift	Part 18 – Sweep Gains
Part 11 – Readout Jitter	Part 28 – Vertical High Frequency Response

### Setup

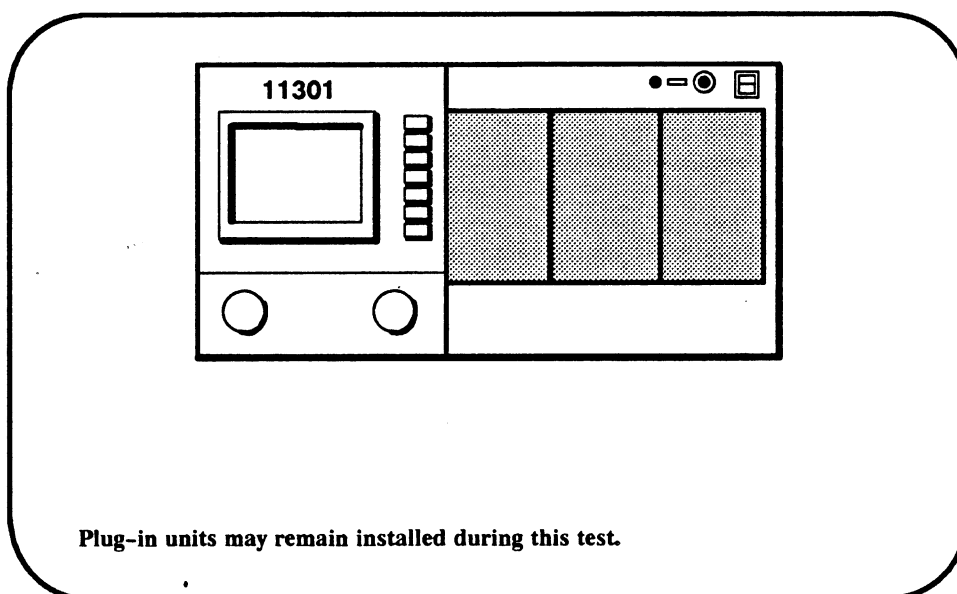

### Procedure

- When running the adjustment test the PC will prompt you to observe whether a brilliant short trace moved across a particular graticule line (e.g. the + or - 4th graticule). This trace moves slowly back and forth on the screen for about five seconds before the PC asks you if the trace crossed a line. Also, you will be asked if some traces were within 0.1 to 0.3 divs from the center graticule line. Figure 2-24 shows the dimensions to measure for each type of trace.

After several crt locations are checked in this way, you will be prompted to observe a waveform that is displayed after the brilliant trace display occurs. You will be asked whether the peak of the waveform is between 3 and 4 divisions above or below the vertical center line. Figure 2-25 shows a possible waveform peak that is within the desired amplitude range. When the waveform is just touching the 4th graticule line, it may be slightly clipped. Clipping is indicated by a flattening of the waveforms peak. Only slight clipping is acceptable.

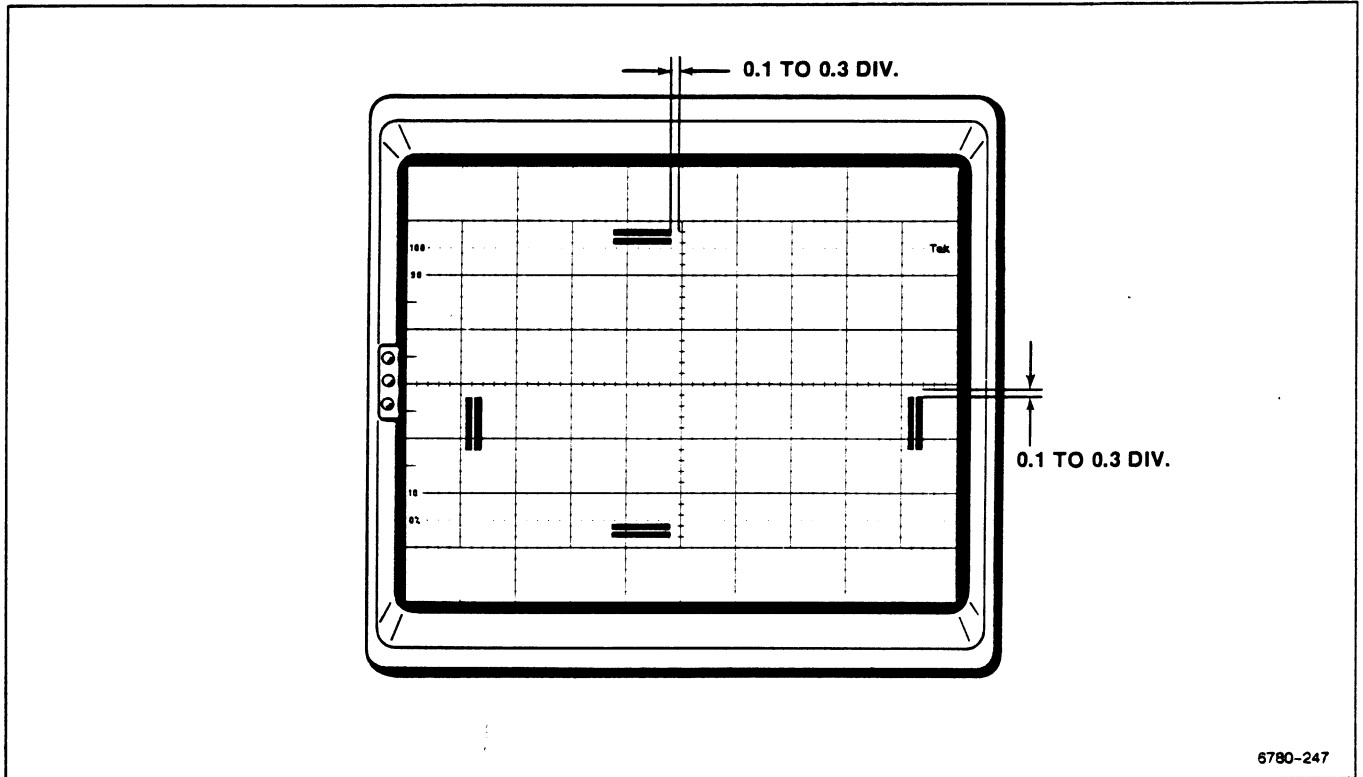

Figure 2-24. CRT display showing the trace to graticule measurements for Beam Registration.

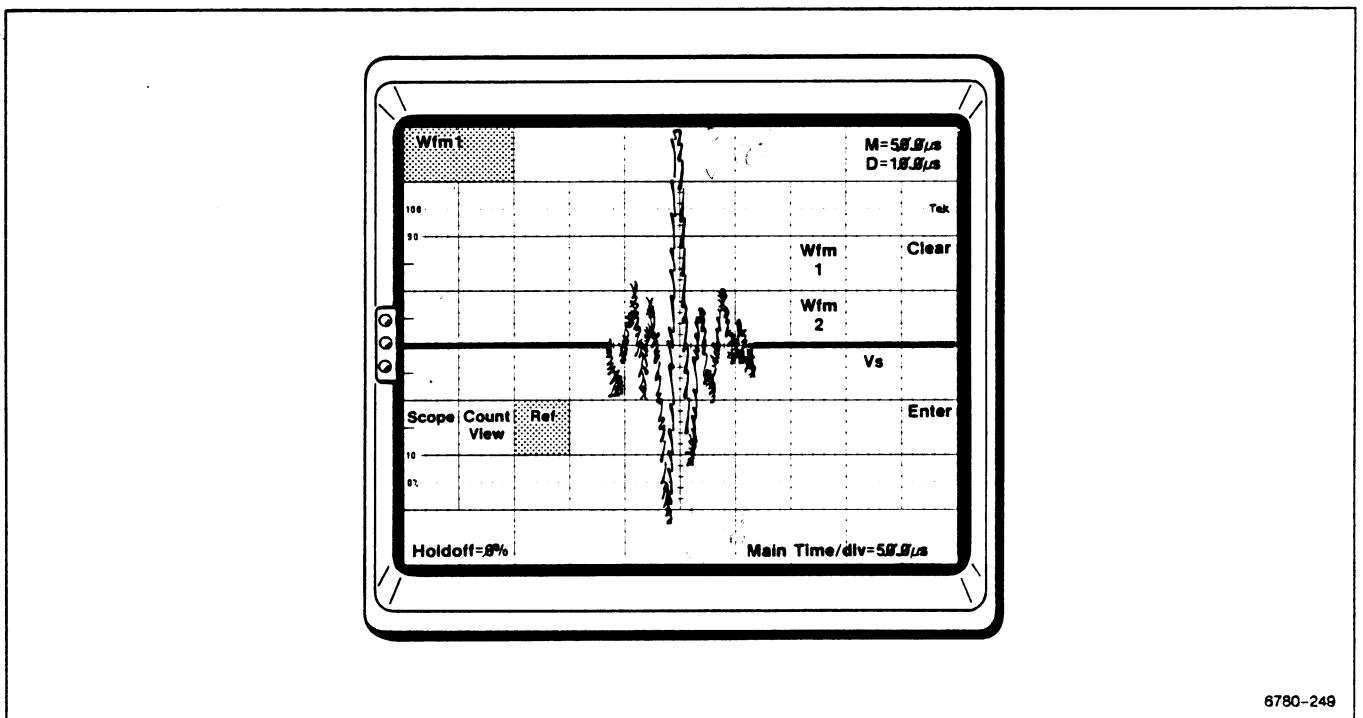

Figure 2-25. CRT display showing an acceptable grat\_prep waveform.

- b. Start the adjustment test **grat\_prep**. Observe the traces and waveforms as described in step c. and answer the PC prompts.

---

## Part 20 – Cursor to Graticule Match

---

### Description

This test checks that the mainframe and an 11000 Series plug-in amplifier can attain Enhanced Accuracy and it checks the alignment of the graticule with the Cursor measurement system.

### Specifications

With the vertical cursors at +3 div and -3 div from center, the  $\Delta\text{Vert}$  readout should be within  $\pm 0.05$  div (over 6 vertical divs). With the horizontal cursors at +4 div (right) and -4 div (left) from center, the  $\Delta\text{Horiz}$  readout should be within  $\pm 0.05$  div (over 8 horizontal divs).

### Setup

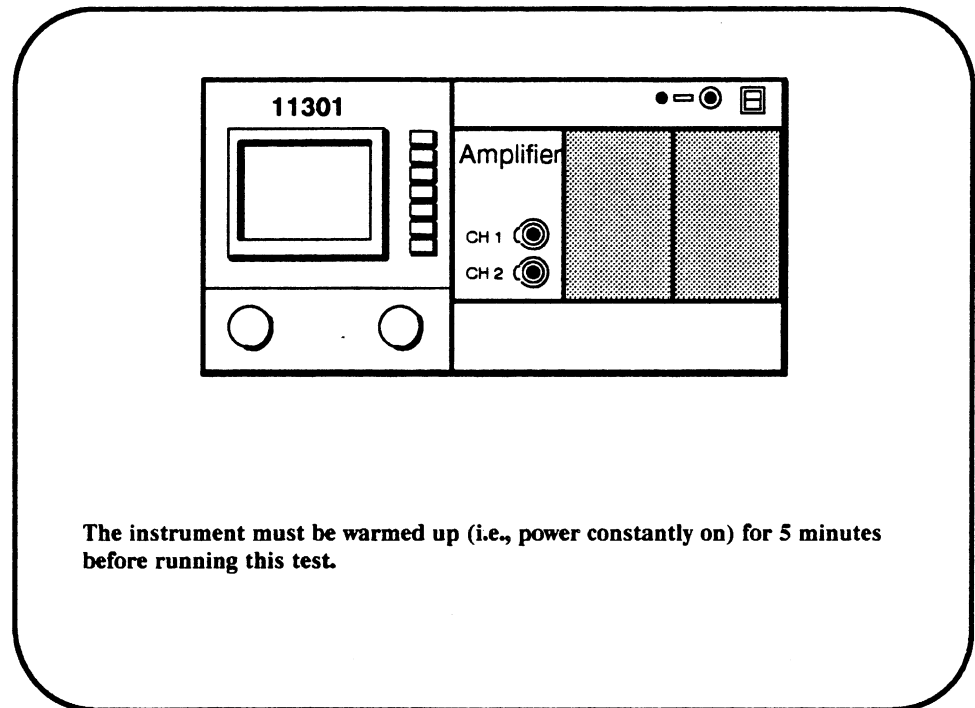

### Procedure

- Press the ENHANCED ACCURACY button twice.
- When the automatic self-calibration is complete, the instrument will enter the normal operating mode and display the EA symbol on the lower right side of the crt. Any failure of the mainframe or plug-in unit to achieve Enhanced Accuracy will cause the instrument to display a calibration failure message.
- Start the test `cal_cur_grat_match`. Follow the instructions given on the PC.

# Part 21 – Reference Oscillator

## Description

The oscilloscope mainframe measures the frequency of a precision time base of known accuracy to determine the accuracy of the mainframe's internal Reference Oscillator.

## Specifications

**Freq** readout of 10 MHz  $\pm$ 50 Hz for the standard mainframe.

**Freq** readout of 10 MHz  $\pm$ 5 Hz for mainframes with Option 1T installed.

## Setup

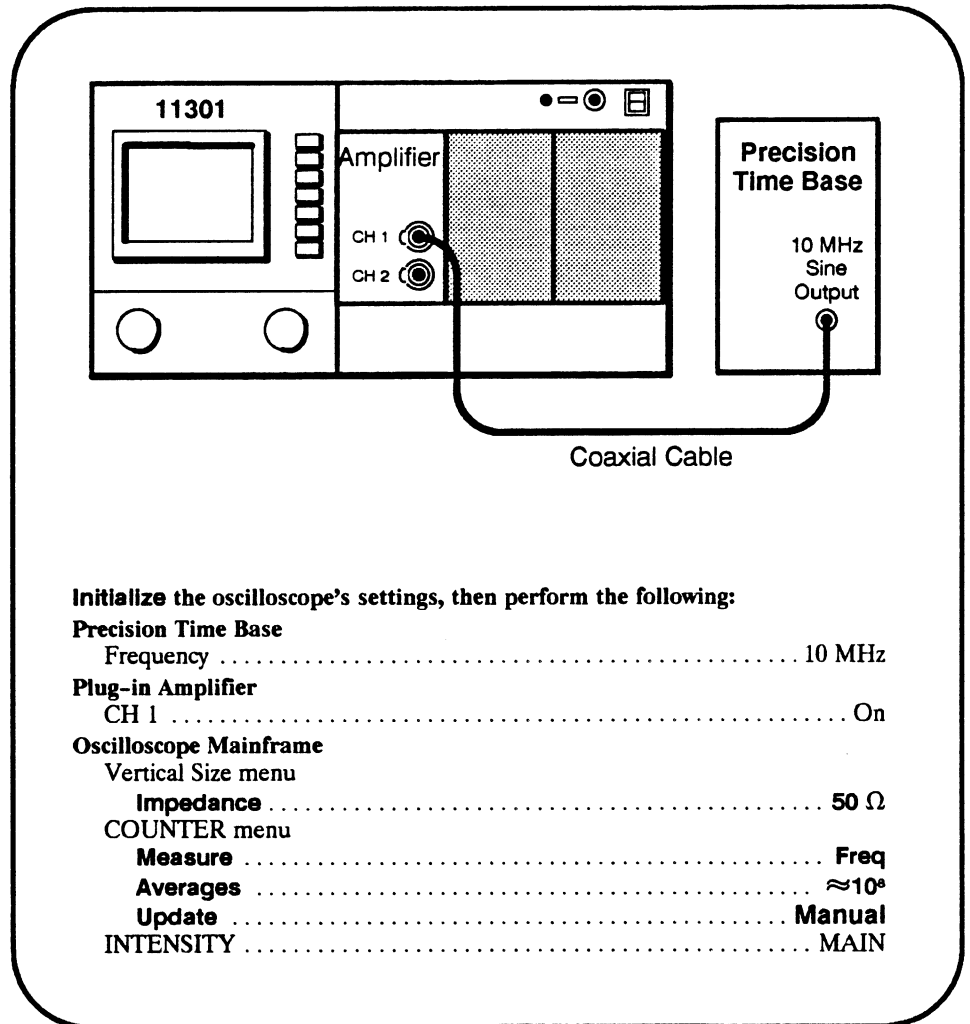

### NOTE

*If a 10 MHz precision source is not available, a 1 Mhz precision source may be used. If the 1 MHz source is used, set Averages to  $10^6$ . Allowed frequency variation is 1/10th that used for 10 MHz.*

**Procedure**

- a. Adjust the display for a vertical amplitude of approximately four divisions.
- b. Press **RESET** in the **TRIGGER** menu. The Frequency measurement takes about two minutes.
- c. **CHECK**—that the **Freq** readout is  $10\text{ MHz} \pm 50\text{ Hz}$  for the standard mainframe or  $10\text{ MHz} \pm 5\text{ Hz}$  for mainframes with Option 1T installed. When Option 1T is installed, the **Freq** readout will show 9 digits instead of the usual 7 digits.



**DO NOT** attempt to adjust the internal Reference Oscillator if the **Freq** readout is within the stated limits. Proceed to the next procedure Part.

*For the standard mainframe:*

- d. Remove top and bottom covers from the mainframe.
- e. Press the **COUNTER** button and select **Auto Update** and  $10^6$  Averages.
- f. **ADJUST**—the **C210** adjustment on the A14 Timebase board until the **Freq** readout of the mainframe is within 5 Hz of the Precision Time Base frequency. Refer to Figure 2-26 for the adjustment location. Select  $10^8$  Averages and perform a final check.

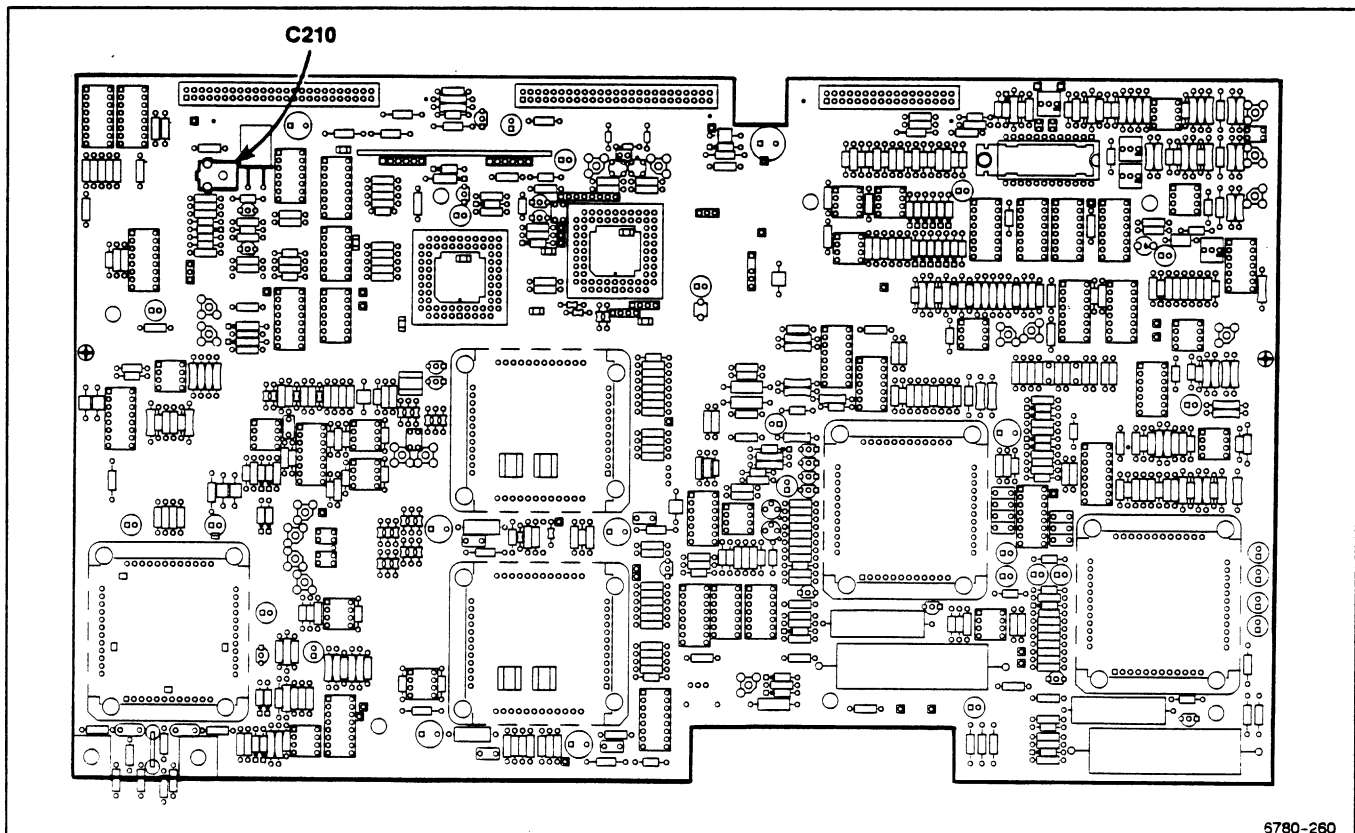

**Figure 2-26. A14 Timebase board (Reference Oscillator) adjustment location.**

*For Option 1T:*

For the optimum adjustment of Option 1T, the mainframe PRINCIPAL POWER SWITCH on the rear panel should be ON for at least 24 hours before the adjustment. The Oven Oscillator has power even when the ON/STANDBY switch is set to STANDBY.

- d. Remove the rear panel behind the crt. See Figure 2-27A and refer to the Maintenance section for more information. Press the COUNTER button and select **Auto Update** and **10<sup>8</sup> Averages**.
- e. **ADJUST** – the Oven Oscillator frequency so it is within  $\pm 0.2$  Hz of the Precision Time Base frequency. See Figure 2-27B for the location. Select **10<sup>8</sup> Averages** and perform a final check.

A.

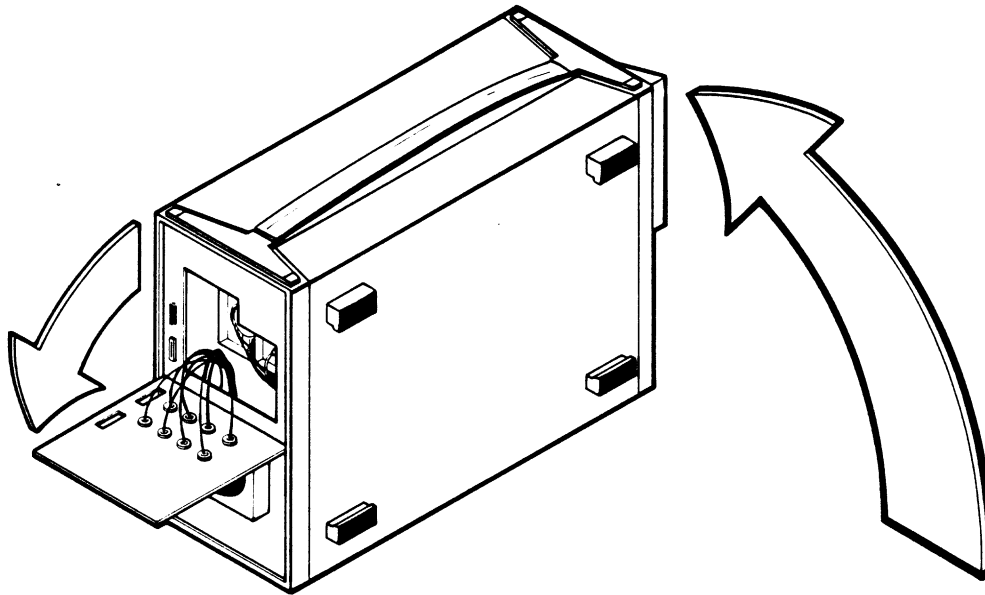

PLACE 11302 ON RIGHT SIDE AS SHOWN  
REMOVE REAR PANEL SCREWS (REFER TO MAINTENANCE  
SECTION) AND ALLOW REAR PANEL TO HANG LOOSE AS SHOWN.

B.

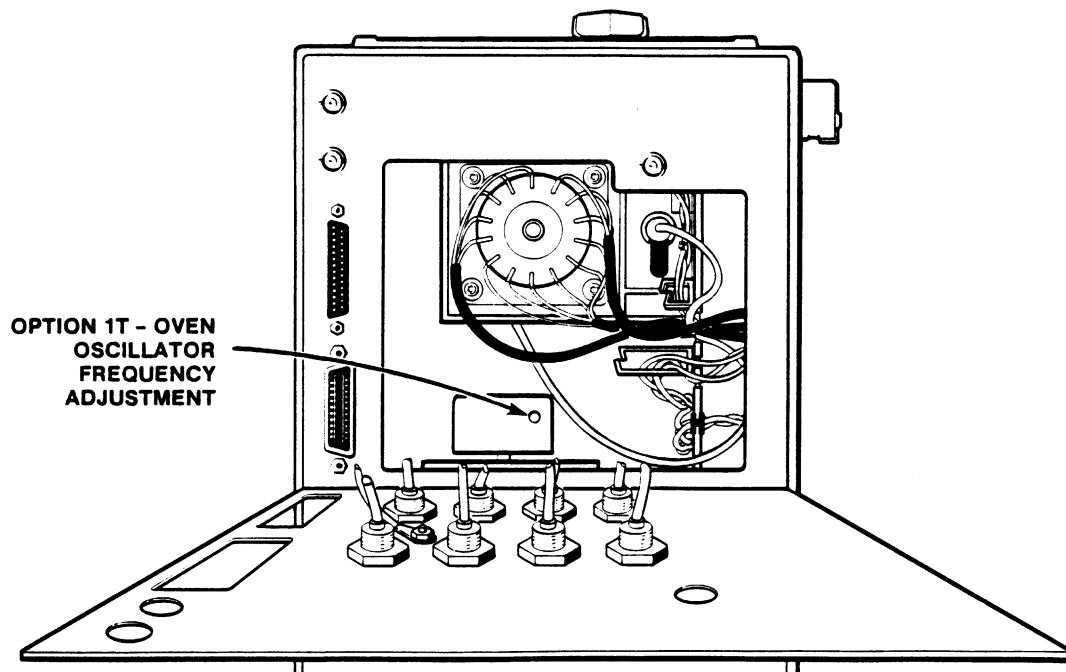

6780-243

Figure 2-27. Location of the Option 1T Oven Oscillator Adjustment.



## Part 22 – Front Panel Calibrator

### Description

This test checks the precision of the front panel CALIBRATOR output by comparing it to a reference signal from an external Calibration Generator.

### Specifications

The CALIBRATOR output specifications are:  
5 V square wave,  $\pm 1.0\%$  into a 1 M $\Omega$  load,  
500 mV square wave,  $\pm 1.0\%$  into a 1 M $\Omega$  load  
500 mV fast rise, > 500 mV into a 1 M $\Omega$  load

### Setup

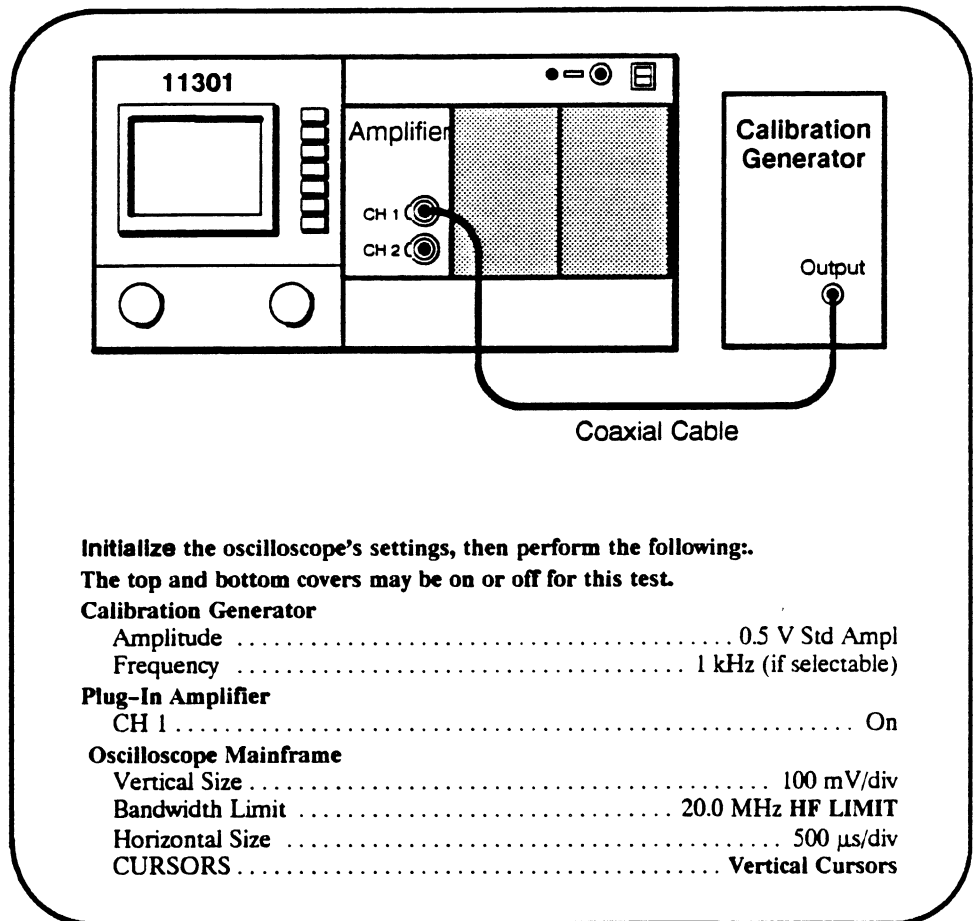

### Procedure

- Select VERTICAL POS and center the trace vertically on the screen.

#### NOTE

*To minimize noise interference of the calibration signal, set any nearby sine wave generators to their reference (lowest) frequencies.*

- Use the vertical cursors to measure the amplitude of the waveform. Use the FINE knob settings, and set the reference cursor to split the waveform bottom and the measuring cursor to split the waveform top.

- c. Touch the **Set Ref** area and the **%–dB** screen area to set it on.
- d. Move the cable from the Calibration Generator output to the 11301 CALIBRATOR output.
- e. Press the UTILITY button, select **Cal Sig**, and set the CALIBRATOR output to a **500 mV Sq Wave** at 1 kHz.
- f. Adjust the cursors to measure the calibrator signal. **CHECK**—that the  $\Delta$ Vert readout is between 99.0% and 101.0%.
- g. Set the CALIBRATOR output to **Fast**.
- h. Adjust the cursors to measure the calibrator signal. **CHECK**—that the  $\Delta$ Vert readout is 100% or greater.
- i. Set Vertical Size to 1 V/div.
- j. Move the cable from the front-panel CALIBRATOR output back to the Calibration Generator output. Set the Calibration Generator output to 5 V.
- k. Adjust the cursors to measure the amplitude of the new signal and touch **Set Ref**.
- l. Move the cable from the Calibration Generator output to the CALIBRATOR output.
- m. Press the UTILITY button, select **Cal Sig**, and set the CALIBRATOR output to a **5 V Sq Wave** at 1 kHz.
- n. Adjust the cursors to measure the calibrator signal. **CHECK**—that the  $\Delta$ Vert readout is between 99.0% and 101.0%.
- o. Press the COUNTER button beneath the screen and select **Freq Measure**.
- p. **CHECK**—that the **Freq** readout is between 998.0000 Hz and 1.002000 kHz.

**NOTE**

*If nine digits are displayed Option 1T (Oven Oscillator) is installed in the mainframe. Normally only seven digits are displayed.*



DO NOT adjust the CALIBRATOR if the output was within specifications. Proceed to the next procedure Part.

# Front Panel CALIBRATOR Output Adjustment

## Setup

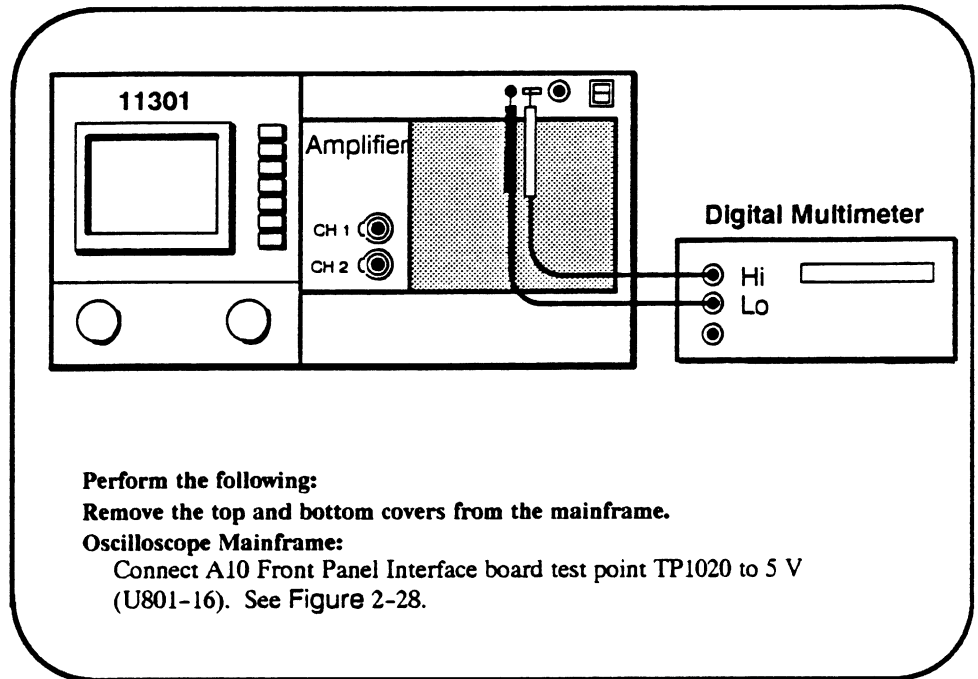

## Procedure

- a. Start the test `frnt_pnl_cal`. Follow the instructions given on the PC.
- b. When the test is finished remove the connecting strap from TP1020.

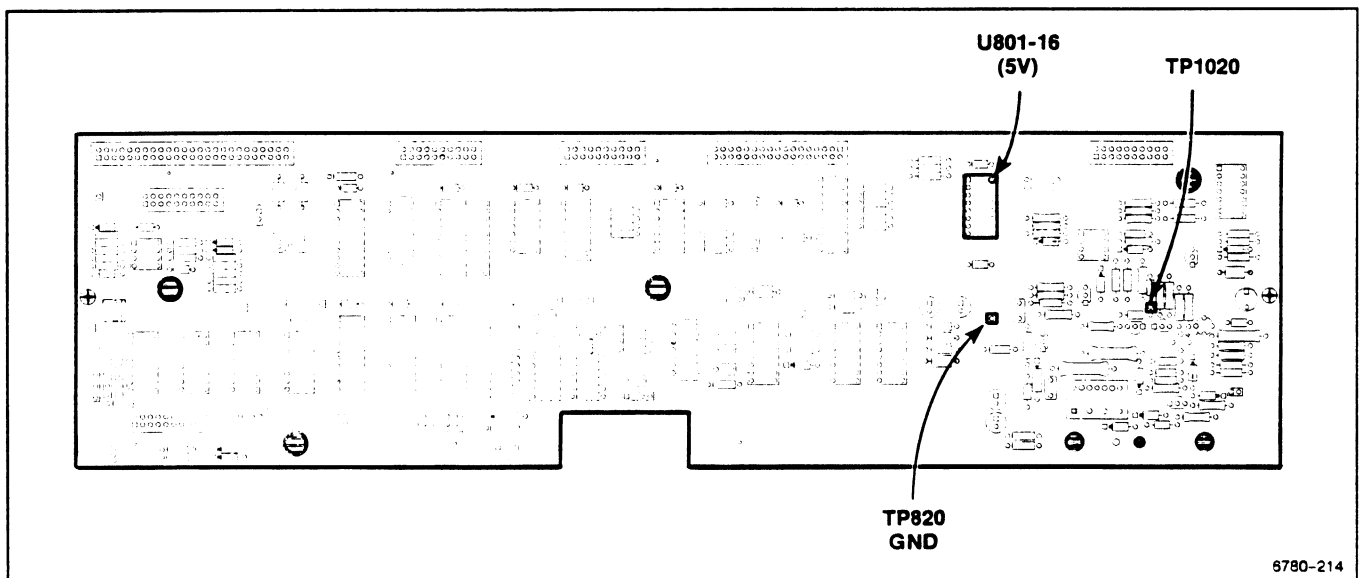

**Figure 2-28.** A10 Front Panel Interface board (Calibrator) test point locations.

# Part 23 – Intensity Settings

## Description

This test checks the Autoset and Enhanced Accuracy intensity settings.

## Setup

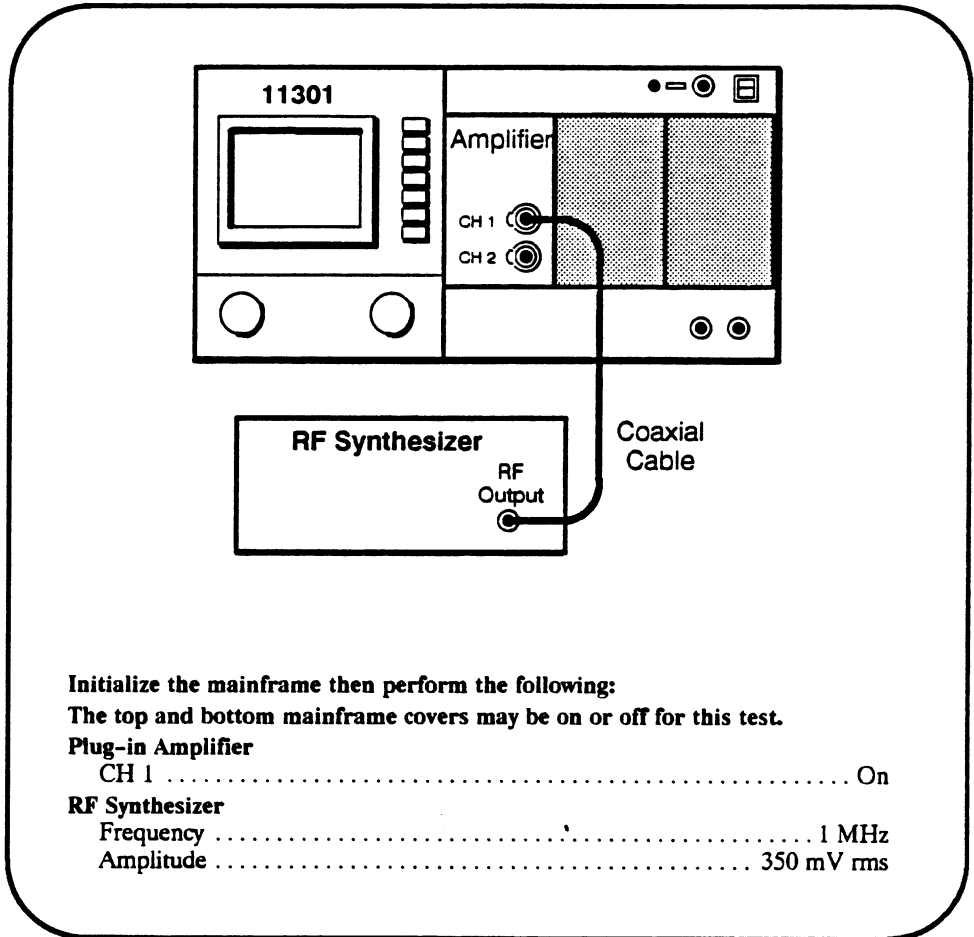

## Procedure

### Autoset Intensity Check

- Press the AUTOSSET button.
- Verify that the final waveform intensity is at an acceptable level.  
 **DO NOT** proceed with the Autoset Intensity adjustment (step c.) if the intensity level in the verification phase was acceptable. Proceed to the Selfcal Intensity Check.
- Start the test **autoset\_bright**. Follow the instructions given on the PC. When the test finishes, proceed with the following check.

*Selfcal Intensity Check*

- d. Disconnect the cable from the 11K Amplifier CH 1 input.
- e. During the following test watch the crt for dot intensity levels that are not too dim or too bright (i.e., with a halo). Start the test **autocal\_trig** and watch the mainframe oscilloscope crt.
- f. If the intensity is acceptable then proceed to the next check. If no waveforms are visible or they are too bright, then proceed to the following adjustment.



DO NOT attempt adjustment if the verification phase passed.

- g. Start the test **autocal\_bright**. Follow the instructions given on the PC.

---

## Part 24 – Install Instrument Covers

---

### Description

This Part prepares the instrument for the following procedure Parts. The remaining Parts of this procedure must be performed with the top and bottom covers installed (except when you are specifically requested to remove the covers) and with the instrument in the Enhanced Accuracy state.

### Setup

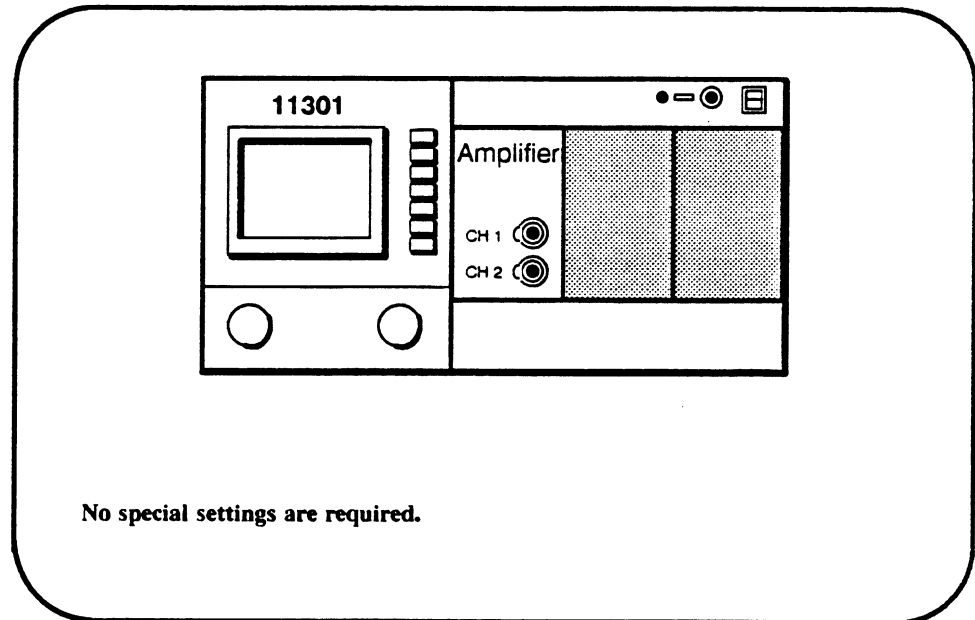

### Procedure

- a. Power down the mainframe and install the top and bottom covers. For instructions see the cover removal/replacement information in the Maintenance section.
- b. Power up the instrument, then wait 10 minutes for the internal temperature to stabilize.
- c. After warming up for 10 minutes, press the ENHANCED ACCURACY button twice to invoke the selfcal system.

#### NOTE

*If the mainframe was cold before starting this procedure Part, let the instrument warm up a full 20 minutes before invoking Enhanced Accuracy. This warmup period is essential to guarantee proper instrument calibration.*

## Part 25 – Sweep Timing Accuracy

### Description

This test checks the accuracy of the sweep timing circuits at significant time/division settings. Both the Main and Delayed timebases are checked in the normal and magnified modes.

### Setup

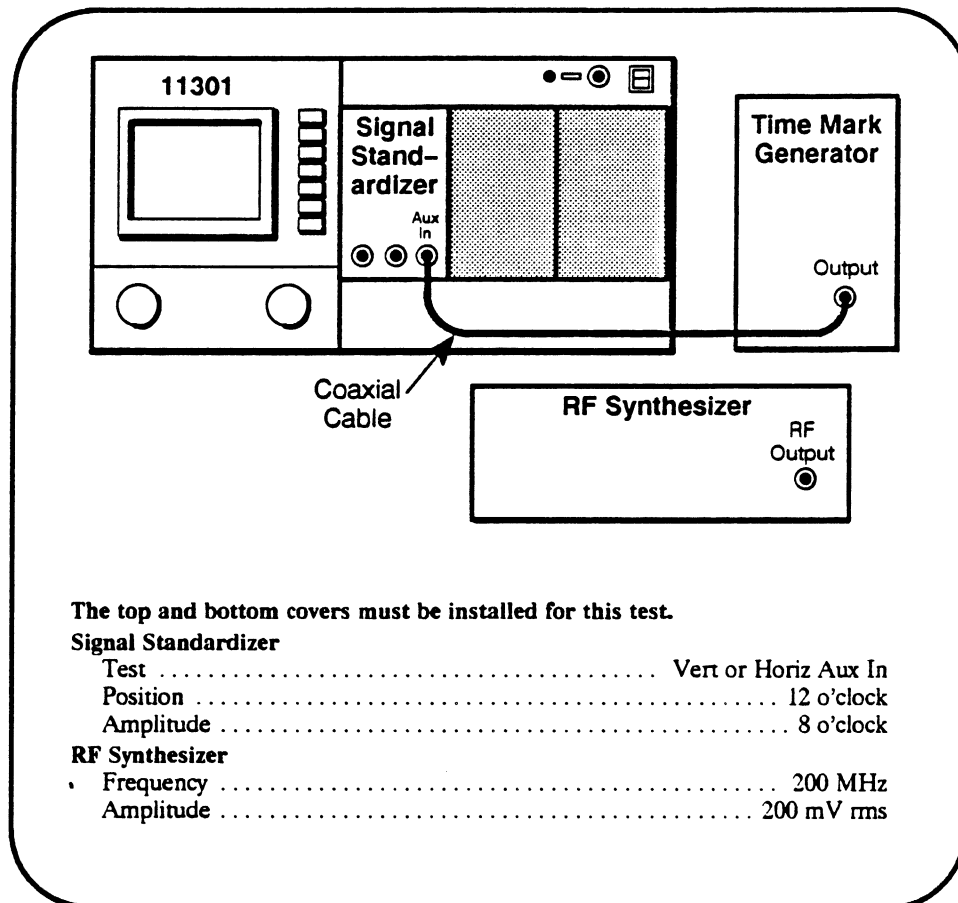

### Procedure

- In the `sweep_timing_acc` test, you will use the horizontal cursors to check the timing at many Main and Delayed time/division settings. At each time/division setting, the PC will prompt you to enter the number of complete cycles between the cursors. Timing accuracy is best (and customarily) checked across the center eight horizontal divisions. If the instrument performance is being verified, the full set of time/division selections should be checked.

When checking magnified sweeps, the first four divisions of the viewable trace (using Horizontal Position) should be excluded. During the test, it may be necessary to increase the waveform intensity and adjust the Horizontal Position to determine where the sweep begins and ends. This is especially helpful at the 500 ps, 1 ns, and 2 ns settings. Also, these three settings are the only ones that should be checked at three places along the sweep (using Horizontal Position).

At the slowest sweep speeds, 200 and 500 ms/div, you will have to count the number of vertical transitions (spikes) that occur as the sweep progresses across the screen. Because of several factors (i.e., chop frequency, intensity, and triggering) you may need to observe several sweeps to properly set the cursors.

- b. Start the test **sweep\_timing\_acc**. When the first trace appears adjust the Signal Standardizer Amplitude and Position controls to obtain a centered 5 to 6 division waveform.



**DO NOT** attempt any of the following Sweep Timing adjustments if all the time/div checks Passed. Proceed to the next procedure Part.

- c. Refer to Table 2-B to determine which of the following sweep timing adjustment tests must be run to correct the failed time/div setting.

**TABLE 2-6**  
**Adjustment Tests to Correct Main and Delayed Sweep Failures**

Time/Div	Adjustment Test or Procedure Part To Run	Sweep Timing Settings to Re-Check
500 ms-500 ns	Part 18-Sweep Gains and Part 19-Beam Registration	All times/div
5 ns	If all time/div slower than 5 ns are good, perform: 5 ns Timing Adjustment Main Sweep 1 ns Timing Adjustment Delayed Sweep 1 ns Timing Adjustment Delayed Sweep 500 ps Timing Adjustment	5 ns/div and faster
2 ns	If all time/div slower than 2 ns are good, perform Part 18-Sweep Gains	All times/div
1 ns	If all time/div slower than 1 ns are good, perform High Speed Linearity Adjustment, and Delayed Sweep 1 ns Timing Adjustment	1 ns and 500 ps/div
500 ps	If all time/div slower than 500 ps are good perform Delayed Sweep 500 ps Timing Adjustment	500 ps/div



# High Speed Linearity Adjustment

## Setup

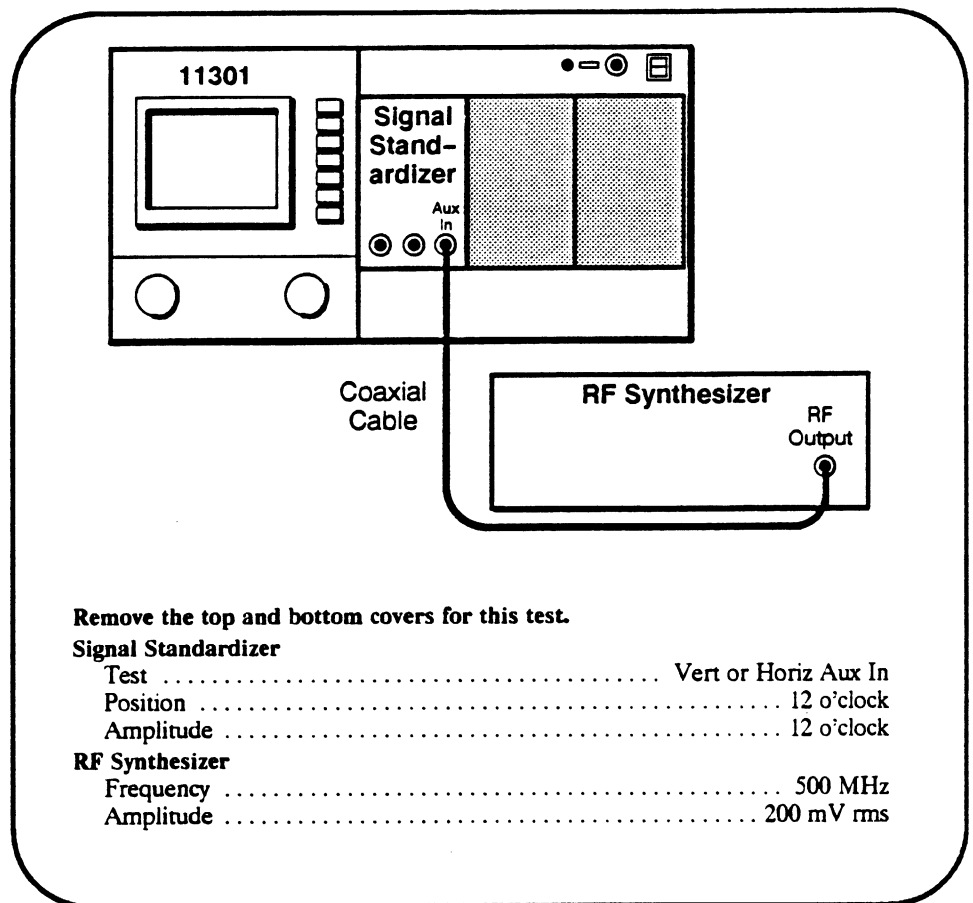

## Procedure



**DO NOT** attempt to adjust the High Speed Linearity unless specifically requested to do so in Table 2-6. It is very unlikely that this adjustment needs to be performed.

- When performing this 1 ns/div sweep linearity check/adjustment, some compromise is necessary between adjusting for the best linearity and the accuracy of high-speed sweep timing. The best approach is to check the linearity, as described below, and make an adjustment only if the linearity is beyond the specified limits. If an adjustment is required, check the timing at 1 ns/div and 500 ps/div again with the Sweep Timing Accuracy test.
- Start the test `hi_spd_adj`. Adjust the DELAYED INTENSITY for a visible trace. Adjust the Signal Standardizer Position and Amplitude controls for a centered Delayed sweep trace with an amplitude of 5 to 6 divisions.

- c. Set the Horizontal Position to about 15, then horizontally position the waveform so that a rising edge of a sinewave is about one division in from the left and right edges of the screen. Carefully adjust the horizontal and vertical position of the waveform so that the extreme left and right rising edges of the sinewave are equal distances from the center graticule line. See Figure 2-29. Dimension A (which is slightly exaggerated here) of your screen display should be as close to equal as possible using FINE control.
- d. **CHECK**—that the rising edge nearest screen center crosses the horizontal graticule line within 0.07 division (1/3 minor div) to the left or right of the center vertical graticule line. Use the center of the trace when checking the linearity error. See Figure 2-29.
- e. Three checks for linearity should be performed at three different sweep positions that are within 20 ns (or 20 divisions) of the extreme left end of the sweep. One check was made in steps c. and d. To check the extreme left end of the sweep, increase the Horizontal Position until the left end of the trace is not visible. This and the next two steps should be performed quickly.
- f. Set the DELAYED INTENSITY to a high level. Increase the Horizontal Position until a dim trace is again seen at the left, then decrease the Horizontal position by 4 divisions.
- g. Set the first rising edge on the display at the minus fourth graticule and proceed with the check as performed in c. and d. above.
- h. Set the Horizontal Position to a value about 10 divisions less than that of the extreme left of the sweep and perform the check in steps c. and d. again.



DO NOT attempt to adjust the linearity if the above checks were within the stated limits. Proceed to the next procedure Part.

- i. Press the carriage return on the PC.
- j. Adjust R1410 on the A14 Timebase board (see Figure 2-30) until the linearity is just within the specified range. Do not adjust R1410 to its full CCW position as the 500 ps timing will be adversely affected.

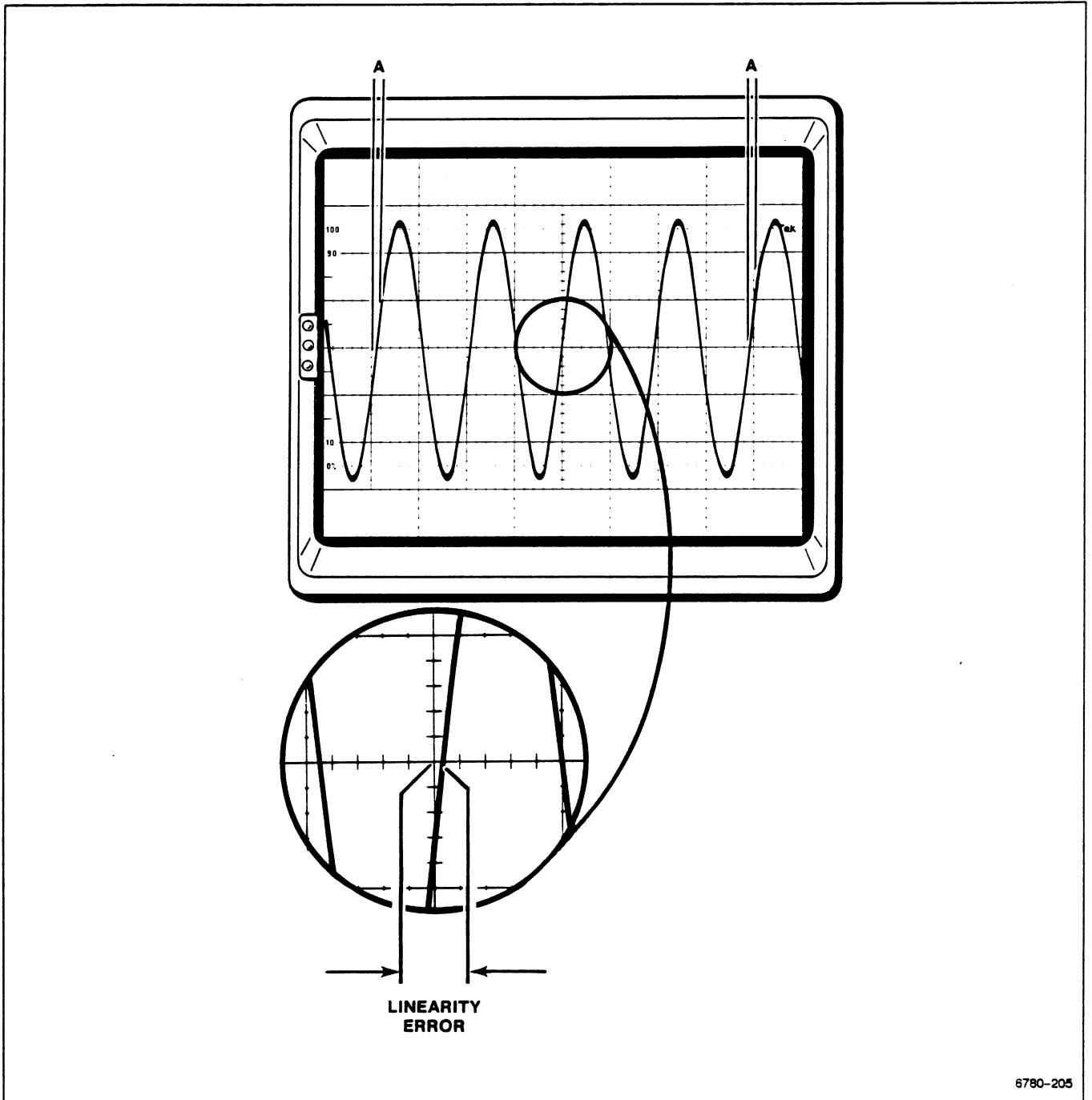

6780-205

Figure 2-29. Waveform alignment for the Linearity measurement (dimension A should be the same at both ends).

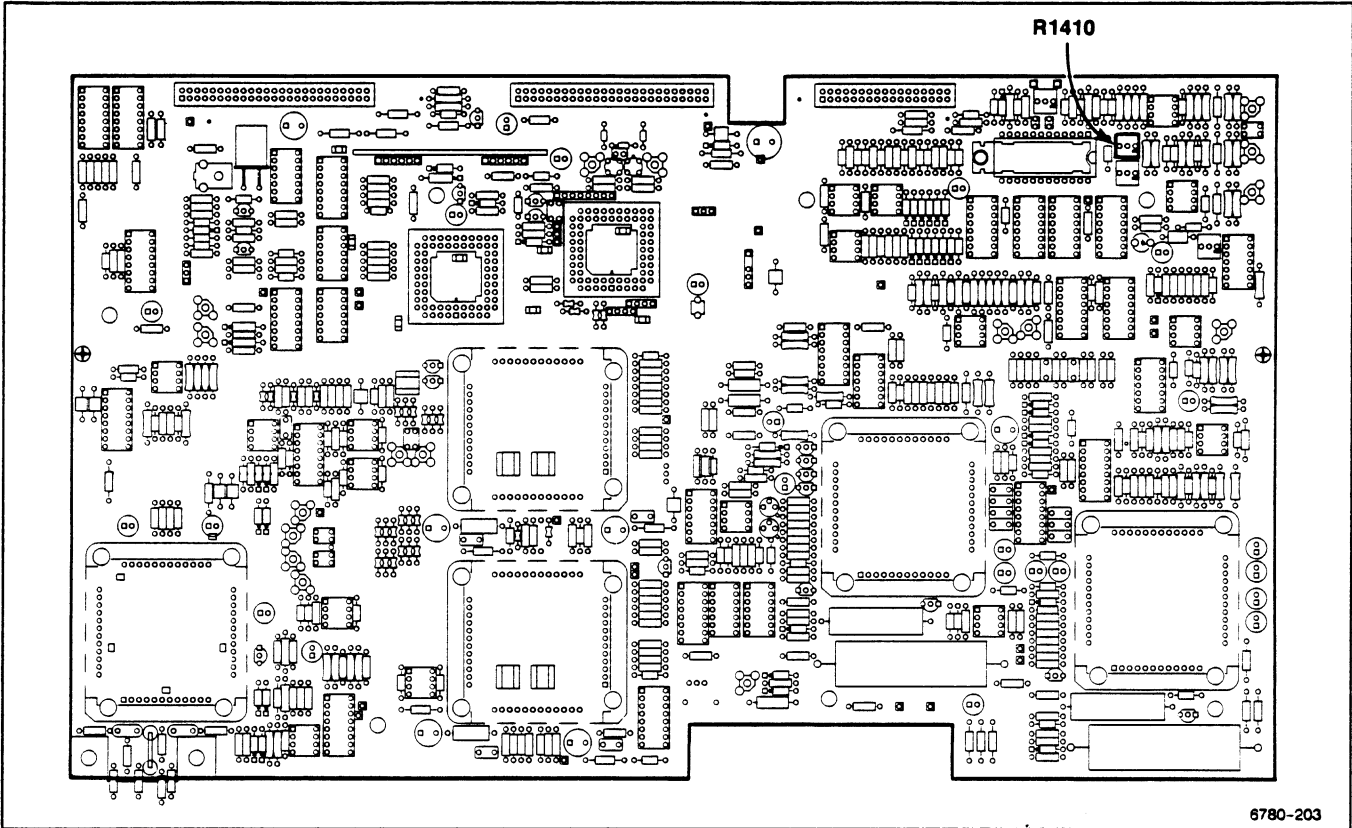
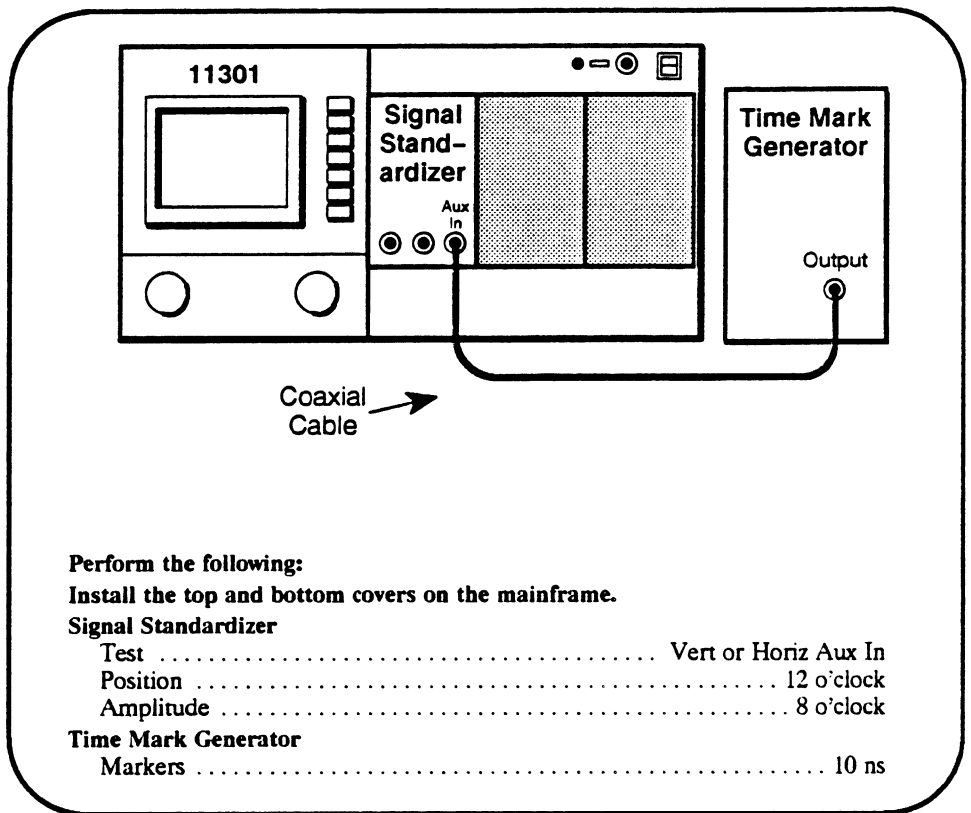

Figure 2-30. A14 Timebase board (High Speed Linearity) adjustment location.

# 5 ns Timing Adjustment

## Setup



## Procedure

- a. Start the test `timing_5ns`. Follow the instructions given on the PC. Note: Each iteration takes about one minute.

## Main Sweep 1 ns Timing Adjustment

### Setup

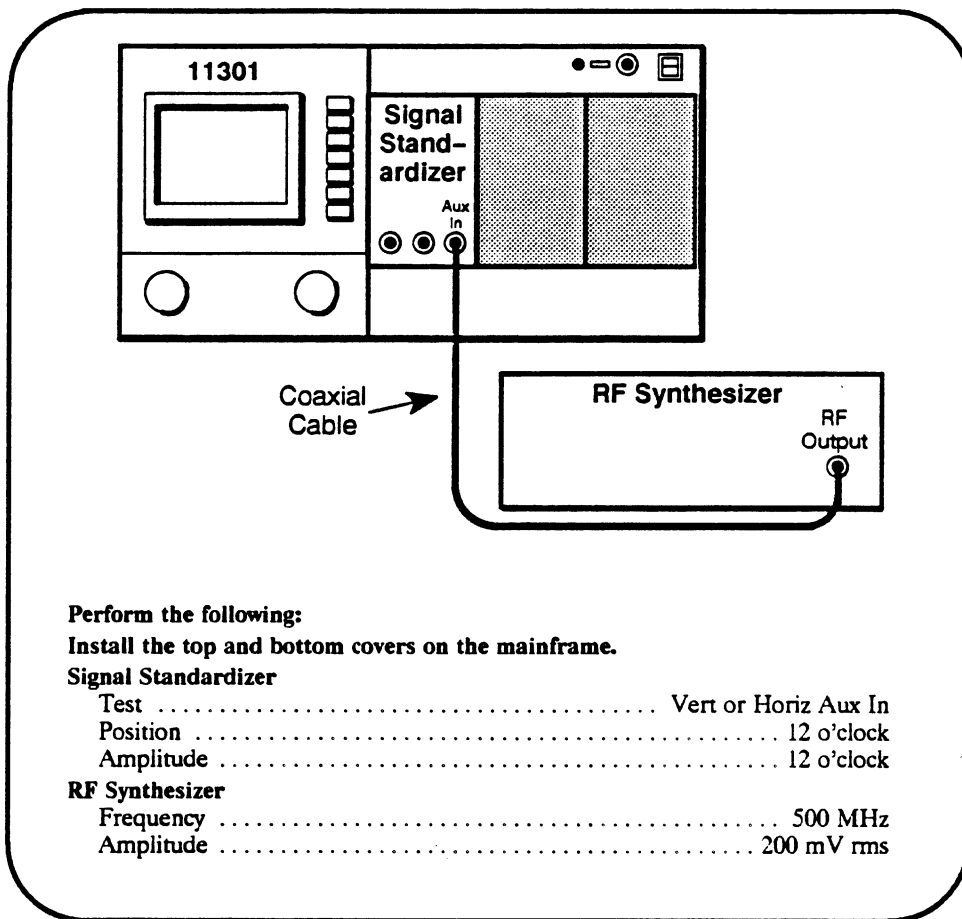

### Procedure

- a. Start the test `a_swp_lin`. Follow the instructions given on the PC.

## Delayed Sweep 1 ns Timing Adjustment

### Setup

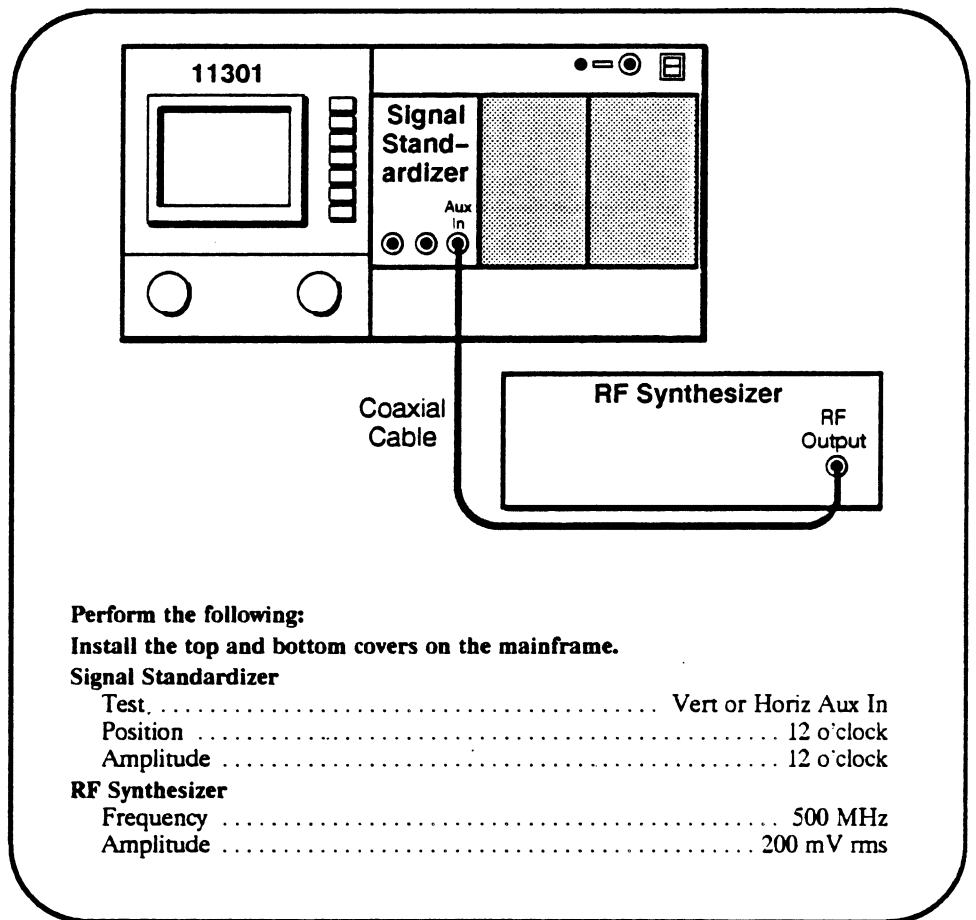

### Procedure

- a. Start the test `b_swp_lin_1ns`. Follow the instructions given on the PC.

## Delayed Sweep 500 ps Timing Adjustment

### Setup

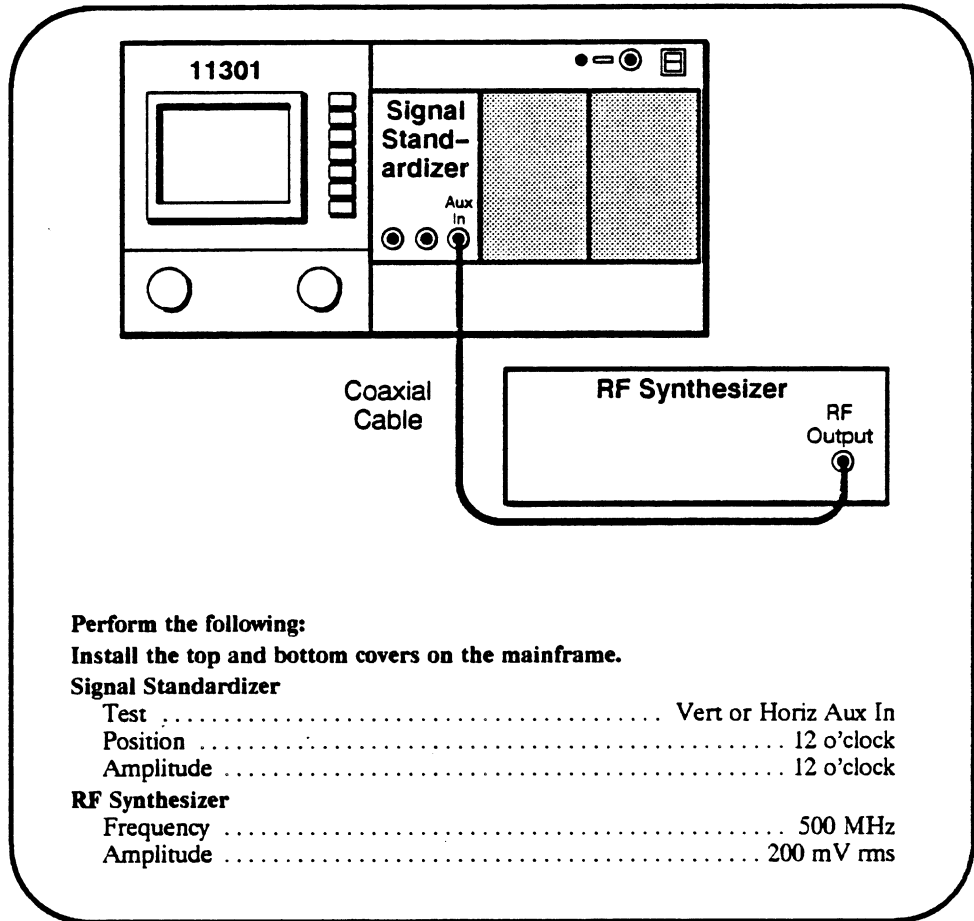

### Procedure

- a. Start the test `b_swp_lin_500ps`. Follow the instructions given on the PC.



# Part 26 – Delta Delay Accuracy

## Description

This test checks the accuracy of measurements made with the delayed (window) sweep circuit.

## Setup

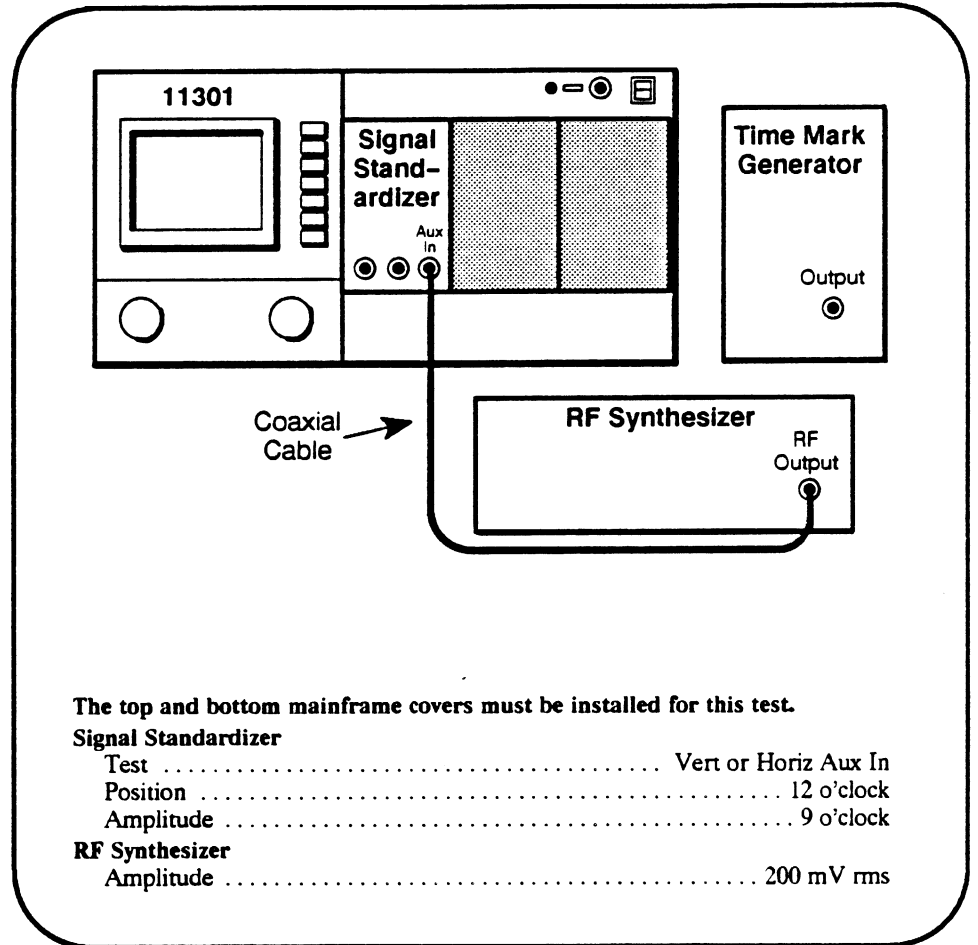

## Procedure

- In this test two waveforms are displayed at each of six times/division. At each time/division you are asked to set the appropriate generator frequency, then adjust Delay2 of the Window2 waveform until it overlays the Window1 waveform. If the waveforms are initially overlaid, appearing as only one waveform, then no adjustment of Delay2 is necessary.

For the slower sweep speeds using the Time Mark generator, the two waveforms actually appear as spikes or “blips” on alternate sweeps. The spikes must be overlaid by noting their positions on alternate sweeps, adjusting Delay 2, then watching for the result on the following alternate sweeps.

- Start the `delta_delay_acc` test and follow instructions on the PC. When prompted to set the Time Mark Generator frequency, disconnect the RF Synthesizer and connect the Time Mark Generator.

---

## Part 27 – Probe Skew Range

---

### Description

This test checks the probe skew system.

### Setup

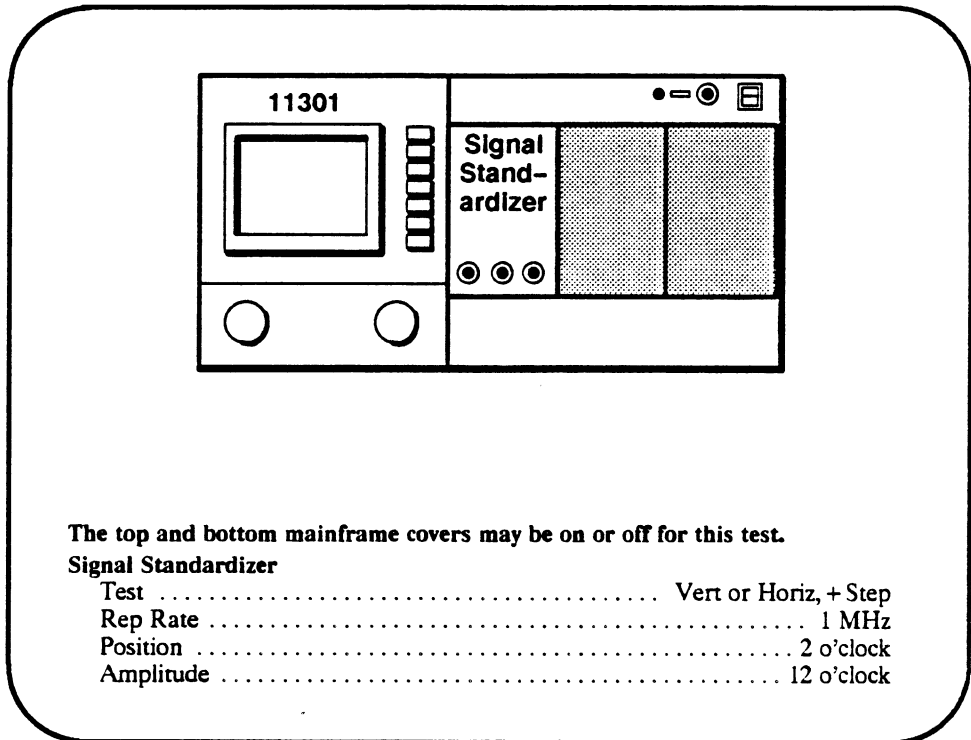

### Procedure

- a. Start the test `probe_skew_adj_rng`. Follow the instructions given on the PC.

---

## Part 28 – Vertical High Frequency Response

---

### Description

This procedure examines the Vertical High Frequency Gain, Counter View Step Response, and Vertical Step Response. If any of these checks fail then the Vertical Amplifier adjustments at the end of this procedure Part must be performed. Any Vertical Amplifier adjustments require that the checks be repeated.

### Measurement Limits

The specifications for frequency range versus amplitude roll off are given in Table 2-7.

**TABLE 2-7**  
**11301 Vertical Gain**

Frequency Range	Amplitude (% of 6 MHz)
150–200 MHz	88.0%
201–250 MHz	86.5%
251–300 MHz	83.2%
301–350 MHz	82.5%
351–400 MHz	79.0%

# Vertical High Frequency Gain

## Setup

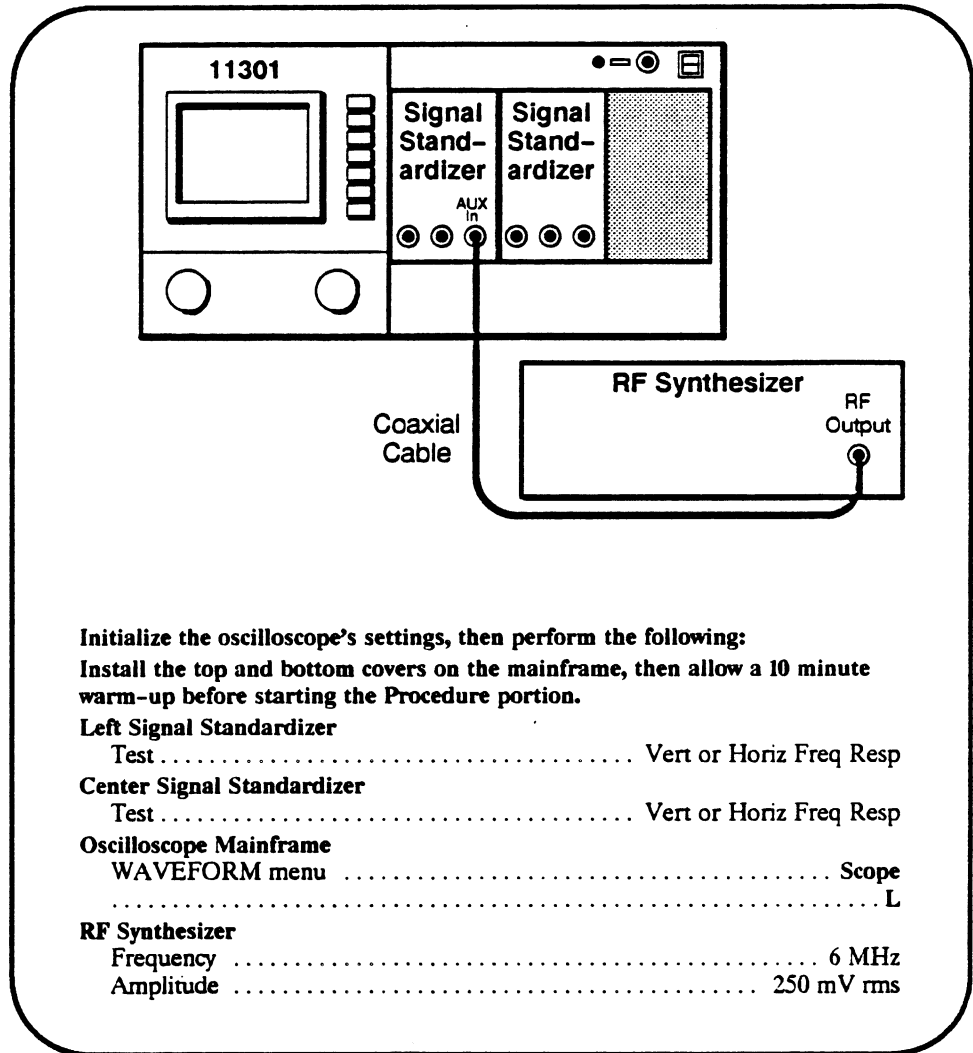

## Procedure

- a. Adjust the left Signal Standardizer for a centered 6 division waveform. The waveform should be a solid band across the screen. Verify that the CW light on the Signal Standardizer is on. If the light is off, the signal from the RF Synthesizer is either too low or high.
- b. Press the CURSORS button and select **Vertical Cursors**. Position the cursors to the top and bottom of the waveform and touch **Set Ref**. The reference value indicated at the bottom of the screen should be between 5.9 and 6.1 divisions.
- c. Select **% dB** and **Tracking** (both should have **On** status). Observe that the  $\Delta$ Vert readout at the left of the screen indicates  $\Delta$ Vert = 100%.
- d. Adjust the left and right Cursor knobs to center the Cursors around the waveform and to set  $\Delta$ Vert equal to 88.0%, the first Amplitude entry in Table 2-7.

- e. Set the RF Synthesizer for 150 MHz.
- f. Adjust the frequency, in 1 MHz steps, up to 200 MHz. If necessary, re-adjust the left knob to enclose the waveform at each frequency step.
- g. **CHECK** – that the amplitude of the waveform is greater than or equal to the spacing between the Cursors (the Amplitude value set previously) over the frequency range from 150 MHz to 200 MHz.
- h. For the remaining entries in Table 2-7, set the RF Synthesizer to the low end of the next Frequency Range in Table 2-7. As in step d., adjust the right knob to set  $\Delta\text{Vert}$  equal to the corresponding Amplitude value. Increment the frequency to the high end of the range using the process described in step f.
- i. **CHECK** – that the amplitude of the waveform is greater than or equal to the spacing between the Cursors (the Amplitude value set previously) over the full frequency range being checked.
- j. When all frequency ranges are checked, move the cable from the Aux In connector of the left Signal Standardizer to the Aux In connector of the Center Signal Standardizer.
- k. Repeat steps a. through i. for the Center Signal Standardizer, including the initial amplitude adjustment of the Signal Standardizer with an RF Synthesizer setting of 6 MHz (as shown in the Setup).

**NOTE**

*In the WAVEFORM menu clear the L (left) waveform and enter C to display the signal from the Center compartment.*



**DO NOT** attempt to adjust the Vertical Amplifier if the above checks were within the stated limits. Proceed to the Vertical Step Response checks.

- l. If any of the checks above failed proceed to the Vertical Amplifier Adjustment at the end of this procedure Part. The Vertical Amplifier Adjustments are quite difficult and should not be attempted just to optimize the vertical system.

## Vertical Step Response

### Setup

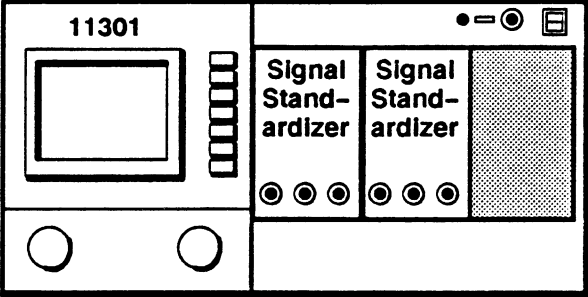

The diagram shows the front panel of the 11301 oscilloscope mainframe. On the left is a screen labeled '11301'. To its right are two 'Signal Standardizer' sections, each with three knobs. Below these are two more knobs. The right side of the panel is a shaded area representing the mainframe control area.

**Initialize the oscilloscope's settings, then perform the following:**  
**Install the top and bottom covers on the mainframe, and allow a 10 minute warm-up before starting the Procedure portion.**

**Left Signal Standardizer**  
 Test ..... Vert or Horiz + Step  
 Rep Rate ..... 1 MHz

**Center Signal Standardizer**  
 Test ..... Vert or Horiz + Step  
 Rep Rate ..... 1 MHz

**Oscilloscope Mainframe**  
 WAVEFORM menu ..... Scope  
 ..... L

### Procedure

- a. Adjust the left Signal Standardizer Amplitude and Position controls for a centered 5 division waveform.
- b. Select the Vertical Cursors and position them to the top and bottom of the waveform.
- c. Select Set Ref from within the Cursors menu then select %-dB. Verify that the  $\Delta\text{Vert} = 100\%$  appears at the left side of the screen.
- d. Set the Horizontal Size to 5 ns/div then adjust the MAIN INTENSITY and Horizontal Position to obtain a viewable waveform.
- e. Press the CURSORS button. Adjust the Right knob so that the dashed cursor is at the highest point of the waveform and adjust the Left knob so that the solid cursor is at the lowest point of the aberrations at the top of the step transition.
- f. **CHECK**—that the  $\Delta\text{Vert}$  readout is 4% or less.

#### NOTE

*The Cursors should split the width of the trace at the point of measurement.*

- g. Press the WAVEFORM button and clear the current left plug-in trace. Now, select C for a center compartment waveform. Exit the Waveform menu by pressing the WAVEFORM button again.
- h. Set the Horizontal Size to 100  $\mu\text{s}/\text{div}$ .
- i. Repeat steps a. to f. for the center plug-in unit.
- j. If any checks are not within tolerance, proceed to the adjustment section at the end of this procedure Part.

## Counter View Step Response

### Setup

**Initialize the oscilloscope's settings, then perform the following:**  
**Install the top and bottom covers on the mainframe.**

<b>Left Signal Standardizer</b>	
Test .....	Vert or Horiz + Step
<b>Center Signal Standardizer</b>	
Test .....	Vert or Horiz + Step
<b>Oscilloscope Mainframe</b>	
WAVEFORM menu .....	Scope
.....	L

### Procedure

- a. Adjust the left Signal Standardizer Amplitude and Position controls for a centered 5 division waveform.
- b. Set the Horizontal Size to 10 ns/div.
- c. Press the WAVEFORM button and select Count View then Count In for display.
- d. Press the COUNTER button then select Freq Measure by touching the lower right area of the screen. The display should now show a five division step waveform and the 1 division Count In waveform.
- e. **CHECK**—that the amplitude of the Count In waveform, as measured between the flat top and bottom portions of the waveform, is between 0.8 and 1.2 divisions.
- f. **CHECK**—that the aberrations at the top of the waveform are no more than 30% of the amplitude measured in step e.



- g. Set the Main Horizontal Size to 20 ns/div.
- h. Adjust the Main Horizontal Position to position the rising edge of the Count In waveform to the center vertical graticule line.
- i. Select 10X Magnify (changes to On status) from the Horizontal Size menu.
- j. **CHECK**—that the Count In risetime, measured from 10 to 90 %, is 2 ns or less.
- k. If any checks are not within tolerance then proceed to the adjustment section at the end of this procedure Part.

## Vertical Amplifier Adjustment

### Description

The Vertical Amplifier adjustments described here are somewhat difficult requiring a number of cycles of adjustment followed by checking then re-adjustment. You should not perform these adjustments except when directed to as a result of the failure of a previous check. If the previous checks showed very poor high-frequency response or very large aberrations, it is likely that the mainframe needs repair. The adjustments required for each vertical check failure are given in Table 2-8

**TABLE 2-8**  
**Vertical Adjustments Required for Check Failures**

Check Failure	Adjustments/Checks to Perform
Vertical Step Response	<ol style="list-style-type: none"> <li>1. Check Medium-Frequency Flatness, adjust as needed.</li> <li>2. Check/Adjust High-Frequency Step Response to reduce aberrations.</li> <li>3. Repeat the checks for Vertical Step Response and Vertical High Frequency Gain.</li> </ol>
Vertical High Frequency Gain or High Frequency Gain and Step Response	<ol style="list-style-type: none"> <li>1. Medium-Frequency Flatness, adjust as needed.</li> <li>2. High Frequency Response, adjust overshoot to just within aberration limits</li> <li>3. Repeat the checks for Vertical Step Response and Vertical High Frequency Gain.</li> </ol>
Counter View Step Response	<ol style="list-style-type: none"> <li>1. Counter View Step Adjustment (Both Vertical Step Response and High Frequency Gain checks must pass before performing this adjustment.)</li> </ol>

## Setup

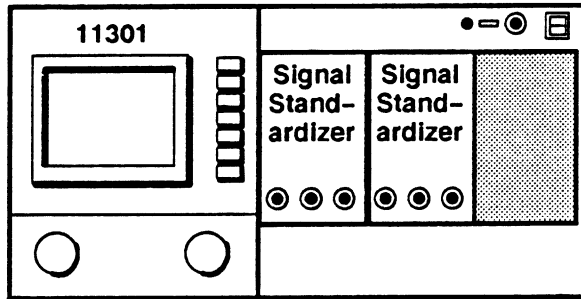

Initialize the oscilloscope's settings, then perform the following:

Install the top and bottom covers on the mainframe.

**Left Signal Standardizer**

Test ..... Vert or Horiz + Step  
Rep Rate ..... 1 MHz

**Center Signal Standardizer**

Test ..... Vert or Horiz + Step  
Rep Rate ..... 1 MHz

**Oscilloscope Mainframe**

WAVEFORM menu ..... Scope  
..... L

## Procedure

- a. Press the DISP ADJ button then carefully adjust the Trace Rotation. Press the button again to exit the menu.
- b. Adjust the left Signal Standardizer Amplitude and Position controls for a centered 5 division waveform.
- c. Press the CURSORS button and select the Vertical Cursors. Position one cursor to the top and one to the bottom of the waveform.
- d. Select Set Ref and %-dB (changes to On status) to establish a reference amplitude of 5 divisions. The  $\Delta$ Vert readout should be 100% (4.9–5.1 divs).

*Check Medium Frequency Step Flatness*

- e. Set the Main Horizontal Size to 20 ns/div.
- f. Use the left Signal Standardizer Position control to position the flat top of the waveform to intersect the center horizontal graticule line.
- g. **CHECK**—that the flat top of the step tilts less than 0.06 divisions (vertical rise) over the 5 horizontal divisions (100 ns) that start 20 ns after the step transition.
- h. If the check passed, proceed to step j., Check High Frequency Response.

### *Adjust Medium Frequency Step Flatness*

- i. If the tilt is beyond the limits then remove the top cover from the mainframe and adjust R510 (see Fig 2-31) for the flattest response (minimize the tilt). R510 will not need to be readjusted after the following adjustments (i.e., it is not interactive). Replace the top cover.

### *Check High Frequency Response*

- j. Set the Main Horizontal Size to 5 ns/div.
- k. Adjust the Horizontal Position so that the step transition is about 3 divisions from the left edge of the screen.
- l. Use the left Signal Standardizer Position control to center the step waveform.
- m. Press the CURSORS button and select **Vertical Cursors**. Position one cursor at the very top of the step and the other cursor at the bottom of the peak aberrations. Due to the small values being measured the cursors should be used in the FINE mode and each cursor should divide the width of the trace.
- n. **CHECK**—that the  $\Delta$ Vert readout is 4% or less.
- o. Press the WAVEFORM button, clear the L waveform, and select the C (center) waveform.
- p. Adjust the center Signal Standardizer Position and Amplitude controls for a centered 5 division waveform as measured between the flat portions at top and bottom.
- q. **CHECK**—that the CENTER compartment aberrations are 4% or less using the same process followed for the LEFT compartment (see step k. above). There is normally a small difference in the step response between the LEFT and CENTER compartments. A large difference indicates an instrument malfunction or a problem with a Signal Standardizer plug-in unit. In the following adjustments, some compromise may be necessary between the best step response and an aberration level within the acceptable limits.
- r. If the High Frequency Response checks passed, perform the Vertical Step Response and Vertical High Frequency Gain checks again.

### *Adjust High Frequency Step Response*

- s. Press the WAVEFORM button, clear the C waveform, and select L. Remove the top and bottom covers.
- t. This adjustment is difficult and should not be attempted unless the previous checks failed. As in other high-performance vertical systems, many of the following adjustments are interactive and must be adjusted for a balance between frequency response and aberrations. If the aberrations are slightly out then only a minor adjustment will be needed. If this adjustment is being performed following a repair, refer to the list in Table 2-9 at the end of this adjustment description for initial settings for the critical adjustments.

The adjustments described below are listed in the order of greatest effect on high frequency to the least effect. See Figure 2-31 for adjustment locations. The setup for adjustment is given after this list.

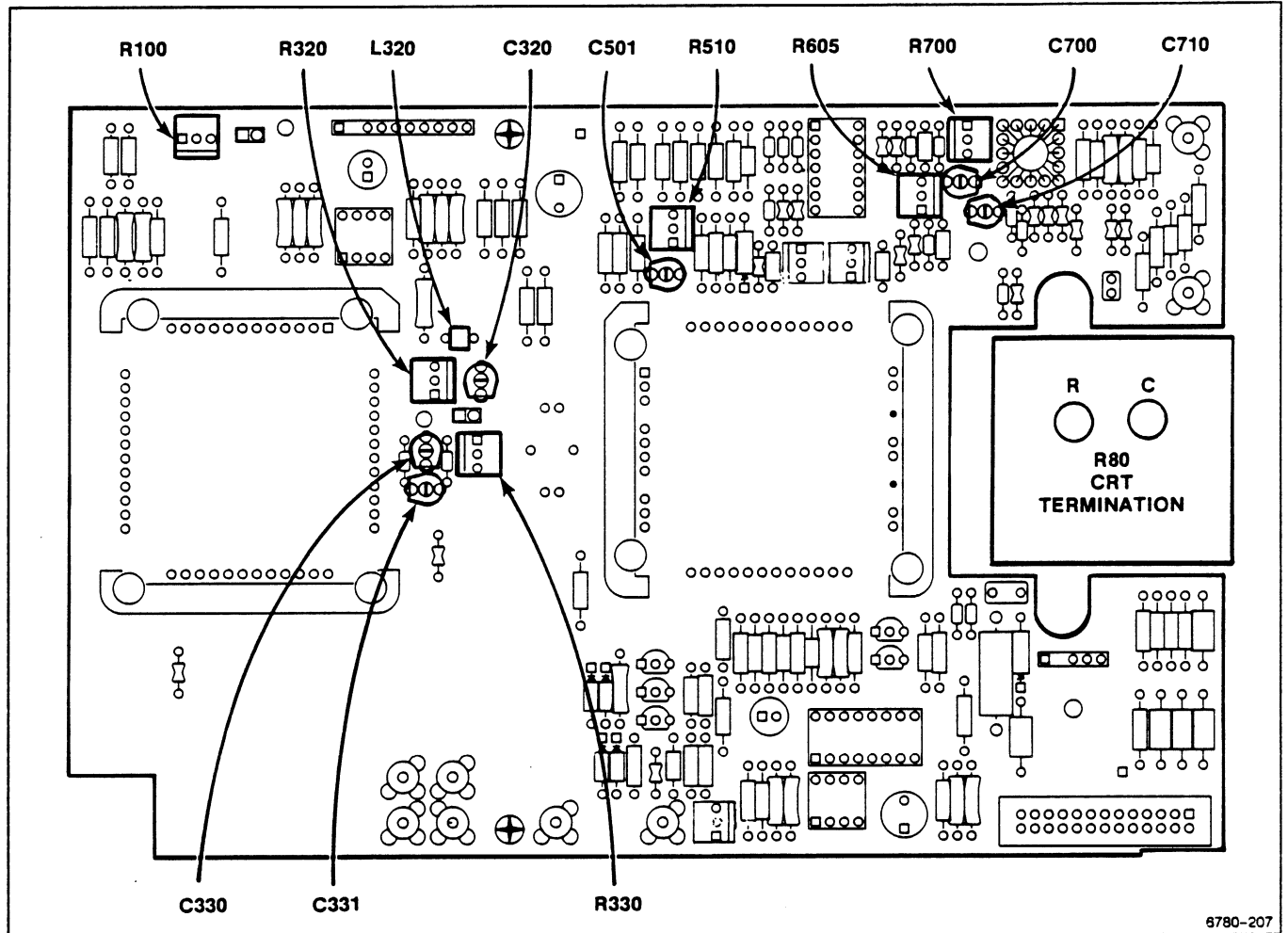

**Figure 2-31. A12 Vertical board (High Frequency Response) adjustment locations.**

**R100** – This is normally set as close to CCW as possible for good high frequency gain without exceeding aberration limits. Re-check Vertical Center if R100 is adjusted.

**C320, R320, L320** – These components are a tuned network. C320 affects slope, R320 dampens ringing, and L320 has a small effect on response. The loop can be squeezed or pulled apart to alter the shape of aberrations.

**R330, C330** – These components compose a tuned network that affect a region of the step response slightly different than C320 and R320.

**C331** – This component affects tilt for about 10 ns after the step transition. C331 is partially under the handle. For better access, remove the handle (Torx T10, T20).

**C501** – This component affects an area about 10 ns after the step transition. After optimizing its setting, it should not need further adjustment.

**CRT Leads** – The leads connecting the Vertical Amplifier board to the crt can be moved closer together to roll the front corner down. DO NOT short the leads to the chassis or pull them off the crt.

**CRT Termination and Wiring** – These should be adjusted if there is a glitch or step about 5 ns after the step transition. Try altering the spacing between the leads from the crt to the termination resistor. These leads should not quite touch. Any bends in the wires should be similar to maintain symmetry.

The termination resistor is unlikely to need adjustment. It changes the relative levels on each side of a transition region that is about 5 ns from the step transition. If the crt has been replaced, optimize this adjustment. Changing the termination resistors value requires that the Plug-in Interface Gains (vertical section), Vertical Center, and Beam Registration procedure Parts be performed again. Press the ENHANCED ACCURACY button twice after running the other procedure Parts.

- u. Adjust the two Vertical Cursors so that they are near the 100% line on the screen. Space them apart so that the  $\Delta$ Vert readout is 4%.
- v. Adjust the left Signal Standardizer Position control to position the top of the waveform between the two Vertical Cursors which indicate the allowable aberration limits.
- w. Adjust the aberrations to be within the limits (Vertical Cursors) by making small incremental changes in the settings of the above listed components. Start at the top of the list and work down. When aberrations are within specifications, stop adjustments. Some aberrations are expected. When you replace the covers you will notice a small amount of roll-off in the first 2 ns after the step transition.
- x. Replace the top and bottom covers. Wait 10 minutes for the temperature to stabilize, then check the Step Response for the LEFT and CENTER compartments. Also, repeat the High Frequency Gain test. If any adjustments were made in this section, perform the following in order:

- Part 12 – Vertical Center
- Part 15 – Plug-in Interface Gains (vertical portion)
- Part 16 – Vertical Center (Second Pass)
- Part 19 – Beam Registration (vertical portion)
- Run selfcal by pressing the ENHANCED ACCURACY button twice.
- Part 28 – Vertical High Frequency Response (check Step Response and High Frequency Gain)

- y. The initial adjustment settings for critical components are listed in Table 2-9.

**TABLE 2-9**  
**Initial Adjustments for Critical Components**

<b>Component</b>	<b>Initial Setting</b>
R100	fully CCW
R320	midrange
R330	midrange
R510	fully CW
CRT Termination Resistor	midrange

z. If any of the following adjustments are inadvertently adjusted refer to:

R570	Part 11 – Readout Jitter
R600	Part 10 – Spot Shift
R610	Vertical Center

## Counter View Step Response Adjustment

### Description

The Counter View Step Response Adjustment should NOT be performed unless the Vertical Step Response and Vertical High Frequency Gain tests have been checked successfully.

### Setup

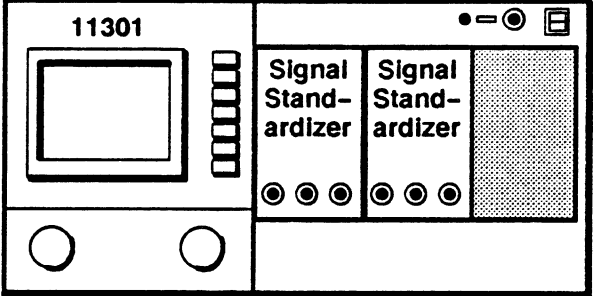

The diagram shows the front panel of an oscilloscope mainframe. On the left, there is a section labeled '11301' containing a square display window and a vertical scale control. To the right of this section are two 'Signal Standardizer' modules, each with three circular indicators below it. Further right is a shaded rectangular area. At the bottom of the mainframe are two circular buttons.

**Initialize the oscilloscope's settings, then perform the following:**  
**Install the top and bottom covers on the mainframe.**

**Left Signal Standardizer**  
 Test ..... Vert or Horiz + Step  
 Rep Rate ..... 1 MHz

**Center Signal Standardizer**  
 Test ..... Vert or Horiz + Step  
 Rep Rate ..... 1 MHz

**Oscilloscope Mainframe**  
 WAVEFORM menu ..... Scope  
 ..... L

- a. Adjust the left Signal Standardizer Amplitude and Position controls for a centered 5 division waveform.
- b. Set the Horizontal Size to 10 ns/div.
- c. Press the WAVEFORM button and select **Count In** for display.
- d. Press the COUNTER button and select **Freq Measure**. The display screen should now have a 5 division step and the 1 division Count In waveform.
- e. **CHECK**—that the amplitude of the Count In waveform, as measured between the flat top and bottom portions of the waveform, is between 0.8 and 1.2 divisions.
- f. **CHECK**—that the aberrations at the top of the waveform are no more than 30% of the amplitude measured in step e.



- 
- g. Set the Main Horizontal Size to 20 ns/div. Horizontally position the Count In waveform to the center vertical graticule line. Press the WAVEFORM button and select 10X Mag to magnify the waveforms to 2 ns.
  - h. **CHECK**—that the risetime from 10%–90% of the Count In waveform is 2 ns (one division) or less.



DO NOT attempt to adjust the Counter View Step Response if the above checks were within the stated limits.

- i. The following adjustments are for aberrations only. The amplitude of the step (0.8 to 1.2 div) is not adjustable. If the amplitude is out of the acceptable range, refer to the Troubleshooting section.

Adjustments to the aberrations also will affect risetime. If either risetime or aberrations exceed specifications, adjust the following components for the best compromise between aberrations and risetime. See Figure 2-31 for the adjustment locations on the A12 Vertical board.

R700  
C700  
R605  
C710

- j. Verify the result of the adjustments with the checks in steps a. to h.

## Part 29 – Vertical/Measurement Accuracy

### Description

This test checks the Vertical Cursor accuracy, the Cursor range, and the Horizontal Cursor measurement accuracy.

### Setup

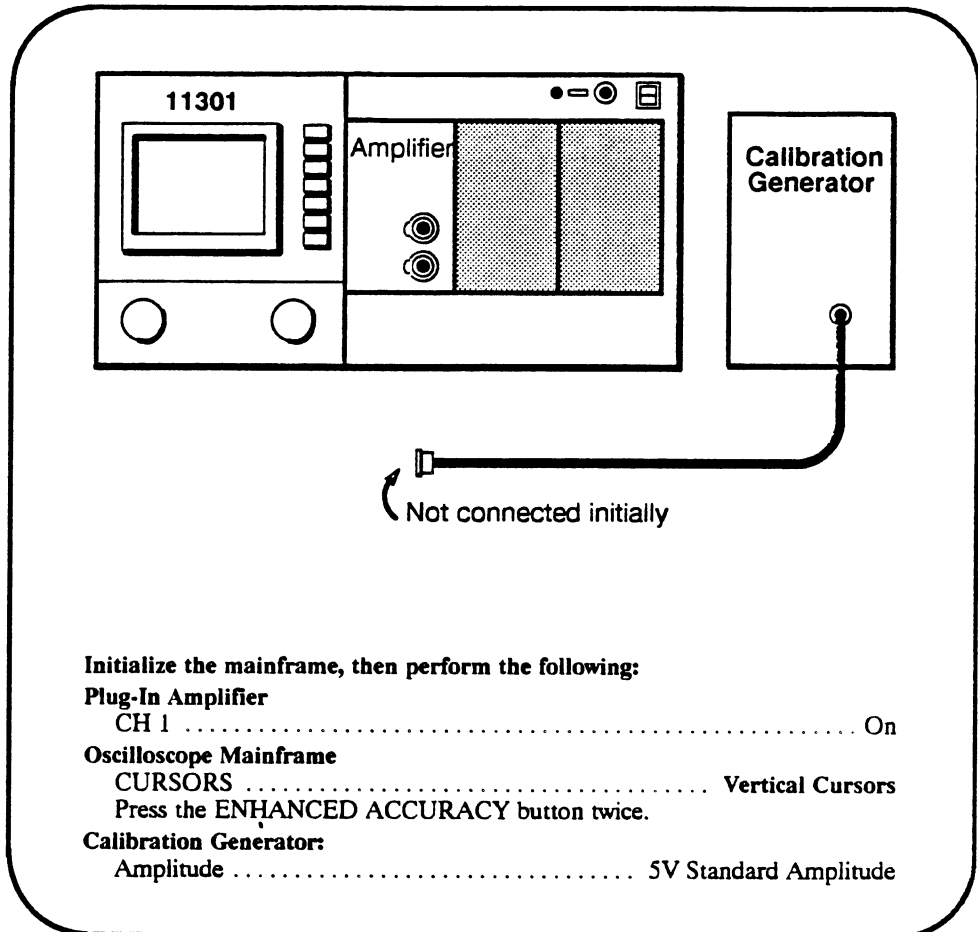

### Procedure

- Adjust the reference cursor (left knob) to the vertical center of the trace. Bisect the trace as exactly as possible using the FINE setting of the knob.
- CHECK**—that the **Vert Ref** readout is within DC Balance specifications in Table 2-10 (next page).
- Adjust the Vertical Offset to position the trace exactly on the horizontal center line.
- Select Vert Pos and set the vertical position to its maximum positive value, 4 divisions.

- e. **CHECK** – That the trace is 3.9 divisions or more above the center horizontal graticule line, measured near the center vertical graticule.
- f. Set the vertical position to its maximum negative value, -4 divisions.
- g. **CHECK** – That the trace is 3.9 divisions or more below the center horizontal graticule line, measured near the center vertical graticule.
- h. Connect the Calibration Generator output to Plug-In CH 1 input.
- i. Center the trace vertically on the screen using Vertical Pos.
- j. Set the Main Horizontal Size to 500  $\mu$ s/div.
- k. Align the cursors to the waveform base and top. Place the reference cursor at the waveform base, and the other cursor at the top.
- l. **CHECK** – that the  $\Delta$ Vert readout is within the specifications of Table 2-10.

**TABLE 2-10**  
Vertical Cursor Tolerances

Plug-In Type	DC Balance (Step b.)	$\Delta$ Vert Accuracy (Step l.)
11A32	$\pm 230$ mV	4.910 – 5.090 V
11A33	$\pm 180$ mV	4.890 – 5.110 V
11A34	$\pm 230$ mV	4.910 – 5.090 V

- m. Press the MEASURE menu button and select **Min**, **Max**, and **P-P** measurements. Touch **START**.
- n. **CHECK** – that the measurement values that appear on the screen fall within the ranges shown in Table 2-11.

**TABLE 2-11**  
Measurement Tolerances

Plug-In Type	P-P	Max	Min
11A32	4.360 – 5.640 V	4.370 – 5.630 V	$\pm 630$ mV
11A33	4.340 – 5.660 V	4.420 – 5.580 V	$\pm 580$ mV
11A34	4.360 – 5.640 V	4.370 – 5.630 V	$\pm 630$ mV

## Part 30 – Trigger Filters

### Description

This test checks for proper operation of the Main and Delayed trigger coupling selections.

### Setup

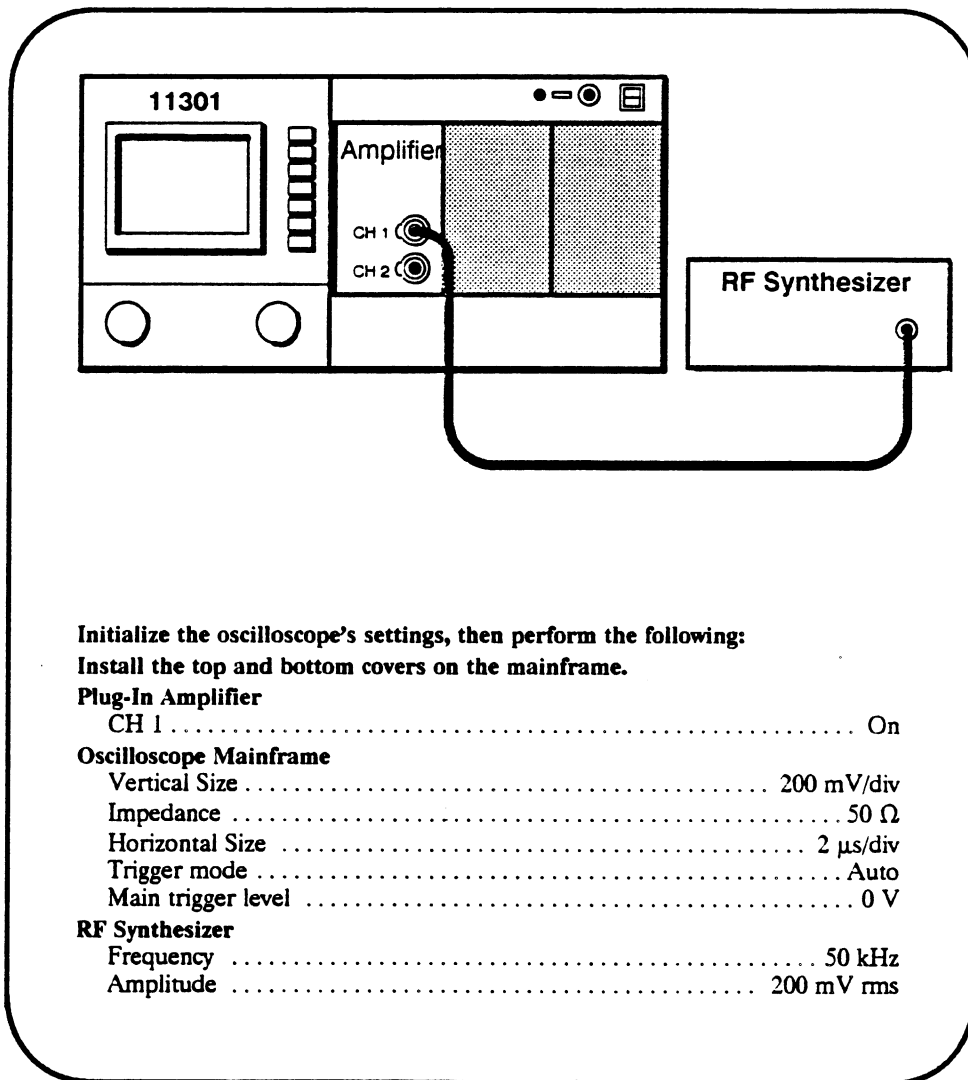

### Procedure

- Adjust the RF Synthesizer Amplitude to produce a waveform about 6 divisions in height.
- Change the VERTICAL OFFSET and as you are turning the knob, **CHECK**—that the signal moves up and down on the screen while the triggering point (the leftmost edge of the sweep) stays at a fixed point on the screen. When you are finished, return the offset to zero.
- Select **AC** coupling for the Main trigger.

- d. Change the VERTICAL OFFSET, and as you are turning the knob, **CHECK**—that the signal moves up and down on the screen while the triggering point (the left most edge of the sweep) also moves up and down. The triggering point should maintain its relationship to the rest of the waveform. When done, return the offset to zero.
- e. Set trigger coupling to **Dc**. Align the falling edge of the sine wave to cross at the center of the screen by adjusting the horizontal position.
- f. Set trigger coupling to **DcHf Rej**. **CHECK**—that the falling edge of the sine wave now crosses the horizontal centerline at a point left of the vertical centerline. The distance to the left should be between 0.6 and 1.8 divisions.
- g. Set trigger coupling to **AcLf Rej**. **CHECK**—that the falling edge of the sine wave has moved between 0.6 and 1.8 divisions to the right of center.
- h. Set trigger coupling to **AcHf Rej**. **CHECK**—that the falling edge of the sine wave has moved between 0.6 and 1.8 divisions to the left of center.
- i. Set the Main Horizontal Size to 5  $\mu$ s, and return trigger coupling to **Dc**. Verify that the **Main Trig** and **L1 Offset** are zero.
- j. Set **Window1** on, **Trig'd After Dly**, and **Dly View**. Set the Delayed Horizontal Size to 2  $\mu$ s, and ensure that the **Dly1 Trig** level is zero.
- k. Change the VERTICAL OFFSET and as you are turning the knob, **CHECK**—that the signal moves up and down on the screen while the triggering point stays at a fixed point on the screen. When you are finished, return the offset to zero.
- l. Select **AC** coupling for the Delayed trigger.
- m. Change the VERTICAL OFFSET and as you are turning the knob, **CHECK**—that the signal moves up and down on the screen while the triggering point also moves up and down. The triggering point should maintain its relationship to the rest of the waveform. When you are finished, return the offset to zero.
- n. Set trigger coupling to **Dc**. Align the falling edge of the sine wave to cross at the center of the screen by adjusting the horizontal position.
- o. Set trigger coupling to **DcHf Rej**. **CHECK**—that the falling edge of the sine wave now crosses the horizontal centerline at a point left of the vertical centerline. The distance to the left should be between 0.6 and 1.8 divisions.
- p. Set trigger coupling to **AcLf Rej**. **CHECK**—that the falling edge of the sine wave has moved between 0.6 and 1.8 divisions to the right of center.
- q. Set trigger coupling to **AcHf Rej**. **CHECK**—that the falling edge of the sine wave has moved between 0.6 and 1.8 divisions to the left of center.

# Part 31 – Trigger Noise and Sensitivity

## Description

This test checks for a correct trigger sensitivity setting and for an acceptable system noise level by measuring the frequency of a 1 Hz sinewave input.

## Setup

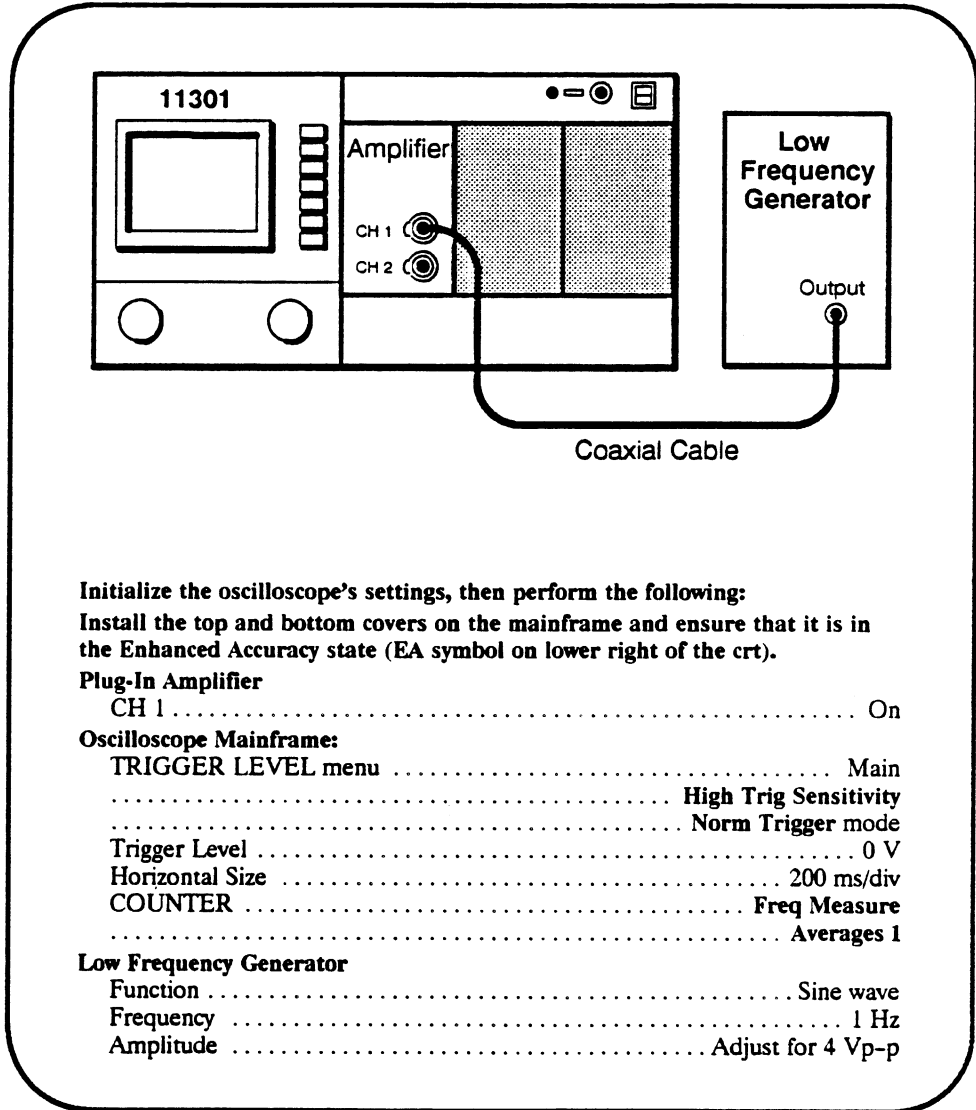

## Procedure

- a. Verify that the period of the displayed sine wave is 5 divisions  $\pm 0.5$  divisions. If not, readjust the Low Frequency Generator for a 5 division (1 second period) sinewave.
- b. **CHECK**—that the Freq readout is between 0.5 and 1.5 Hz.
- c. In the TRIGGER LEVEL menu, select **High Trig Sensitivity** for the Dly1 trigger.
- d. In the COUNTER menu, select the **Dly1 Trig Source** for the Counter Timer.
- e. **CHECK**—that the Freq readout is between 0.5 and 1.5 Hz.

# Part 32 – Trigger Sensitivity

## Description

This test checks for proper operation of the High, Medium, and Low trigger sensitivity selections.

## Setup

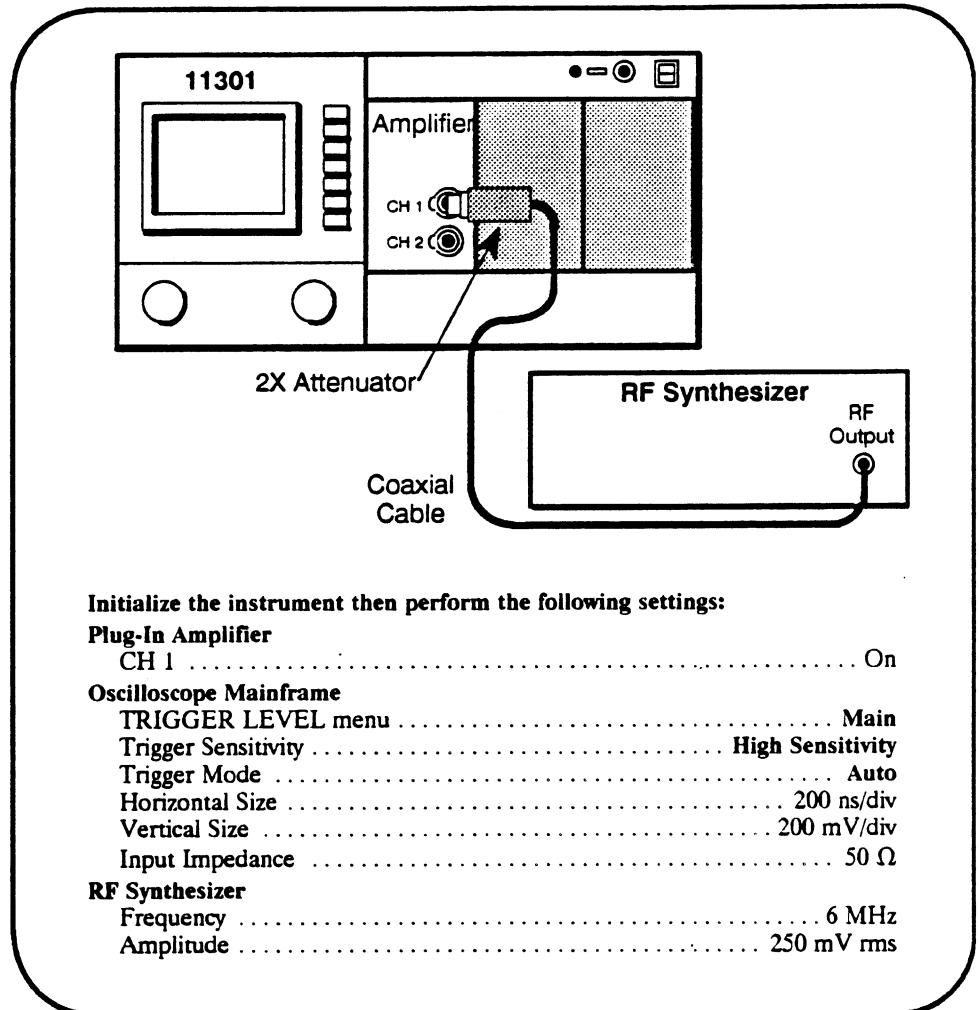

## Procedure

- Adjust the RF Synthesizer Amplitude for a waveform height of 1.75 divisions (350 mV p-p).

Throughout this test, be precise in establishing waveform heights as nearly as possible to the specification. One way this can be accomplished is by using the Vertical Cursor controls. Set **On Tracking** and adjust the  $\Delta$ VERT readout to the voltage specification of the adjustment. Then, by simultaneously using the VERTICAL POS control and adjusting the Amplitude of the RF Synthesizer, the waveform can be matched to the cursor size.

- Set **Window 1** on and adjust **Delay 1** to 0 s.
- Using the VERTICAL POS control, position the Main trace in the top half of the screen and the Window trace in the bottom half. You may need to increase the intensity of the Main and Delayed traces to see the waveforms.

- d. For the Delay 1 Trigger, select **Trig'd After Dly** and **High Sensvty**.
- e. Install a 5X attenuator in series with the 2X attenuator at the plug-in amplifier input.
- f. Adjust the TRIGGER LEVEL of both the Main and Delay 1 triggers.  
*CHECK*—to verify that stable traces can be established on the screen. You will need to use the FINE knob settings. Also, the M TRIG'D and D TRIG'D lights next to the TRIGGER LEVEL button show whether the Main and Delay triggers are active.
- g. Remove the 5X attenuator leaving the 2X attenuator in the signal path.
- h. Adjust the RF Synthesizer for a vertical amplitude of 3.5 divisions, 490 mV rms, for each waveform. If using the cursors, the amplitude is 700 mV p-p.
- i. Reinstall the 5X attenuator in the signal path.
- j. Change the trigger sensitivity of both the Main and Delay 1 triggers to **Medium Sensvty**.
- k. Adjust the TRIGGER LEVEL of both the Main and Delay 1 triggers.  
*CHECK*—to verify that stable traces can be established on the screen.
- l. Remove the 5X attenuator leaving the 2X attenuator in the signal path.
- m. Adjust the RF Synthesizer for a vertical Amplitude of 5.25 divisions, or 742 mV rms. If using the cursors, the amplitude is 1.05 V p-p.
- n. Reinstall the 5X attenuator in the signal path.
- o. Change the trigger sensitivity of both the Main and Delay 1 triggers to **Low Sensvty**.
- p. Adjust the TRIGGER LEVEL of both the Main and Delay 1 triggers.  
*CHECK*—to verify that stable traces can be established on the screen.
- q. Change the trigger sensitivity of both the Main and Delay 1 triggers to **High Sensvty**.
- r. Adjust the Main Horizontal Size to 10 ns. This will force the Delayed Horizontal Size to match.
- s. Remove the 5X attenuator leaving the 2X attenuator in the signal path.
- t. Press the VERTICAL POS button below the screen. Observe the system bandwidth in the **HF Limit** readout at the bottom of the screen and adjust the RF Synthesizer Frequency to match.
- u. Adjust the RF Synthesizer to obtain a vertical trace amplitude of 5.00 divisions, or 700 mV rms.
- v. Reinstall the 5X attenuator in the signal path.
- w. Adjust the TRIGGER LEVEL of both the Main and Delay 1 triggers.  
*CHECK*—to verify that stable traces can be established on the screen.



DO NOT adjust the Trigger Sensitivity if all the verification checks passed. Proceed to the next procedure Part.



# Trigger Sensitivity Adjustment: Main

## Setup

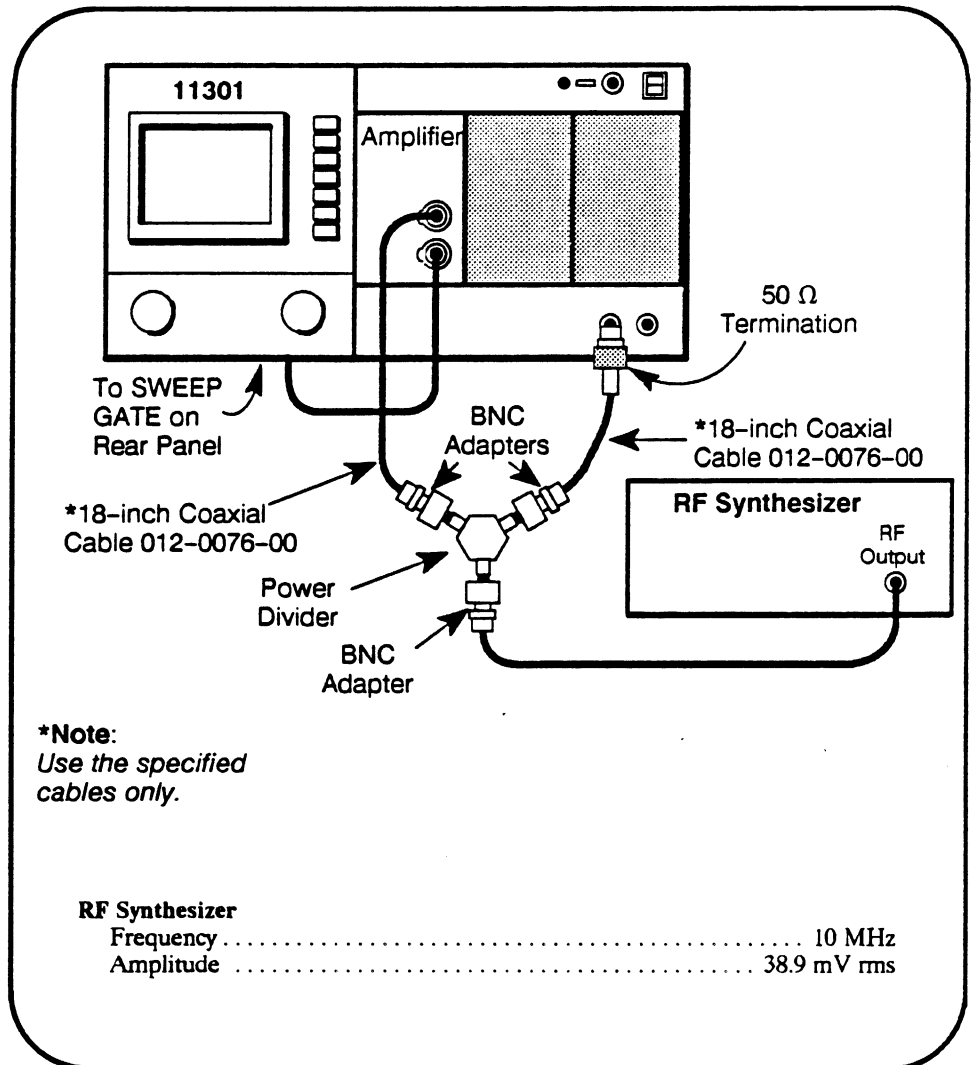

## Procedure

- a. Start the test `trig_sens_main`. Follow the instructions given on the PC.

# Trigger Sensitivity Adjustment: Delayed

## Setup

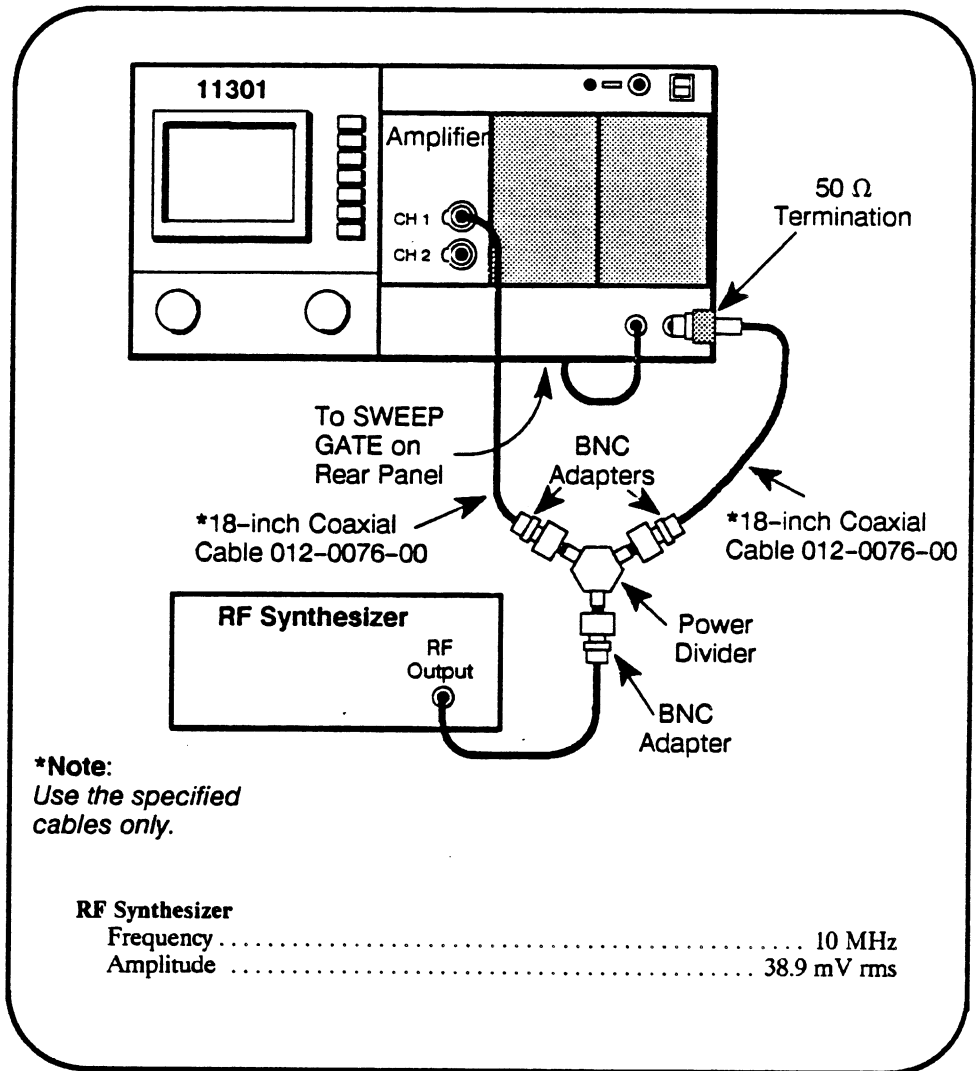

## Procedure

- a. Start the test `trig_sens_delay`. Follow the instructions given on the PC.

## Part 33 – Trigger Accuracy

### Description

This test checks the accuracy of the plug-in trigger path and the two external paths as sources to the External Trigger and to the Counter Timer.

### Internal Trigger Accuracy

#### Setup

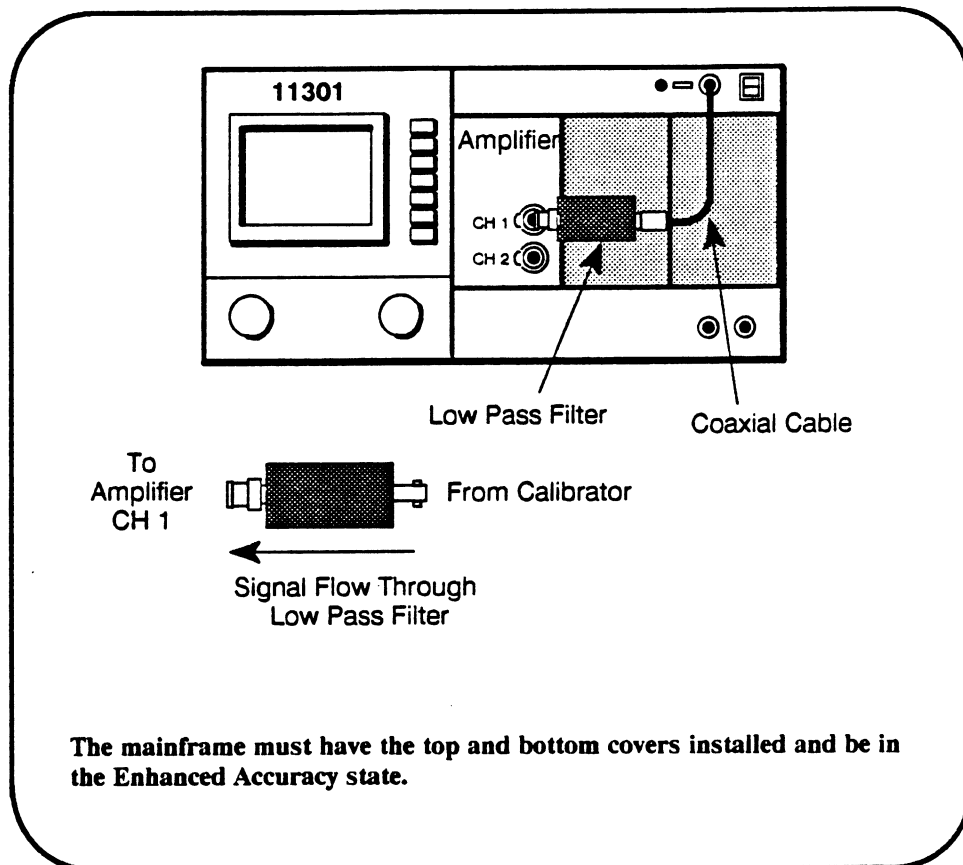

#### Procedure

- a. Start the test `int_trig_acc_pc`. Follow the instructions given on the PC.

## External Trigger Accuracy

### Setup

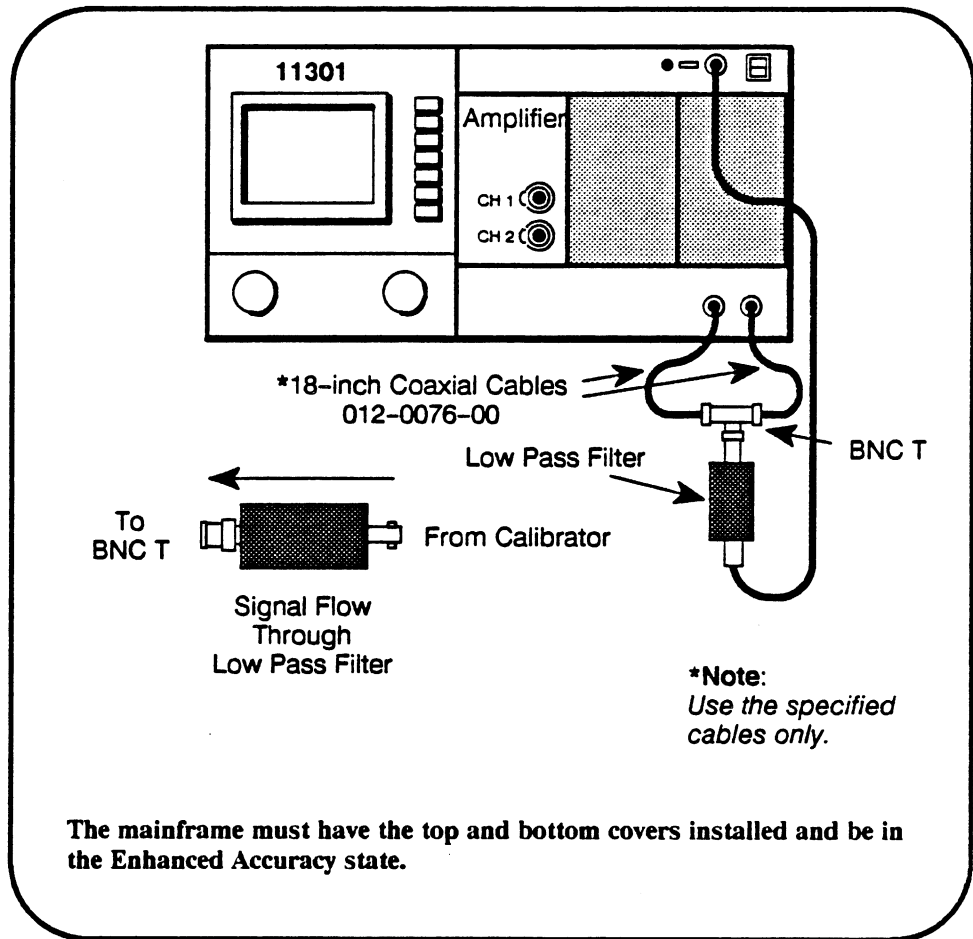

### Procedure

- Start the test `ext_trig`. Follow the instructions given on the PC.



**DO NOT** adjust the External Trigger Accuracy if all the verification checks passed. Proceed to the External Counter Timer Accuracy check.

## External Counter Timer Trigger Accuracy

### Setup

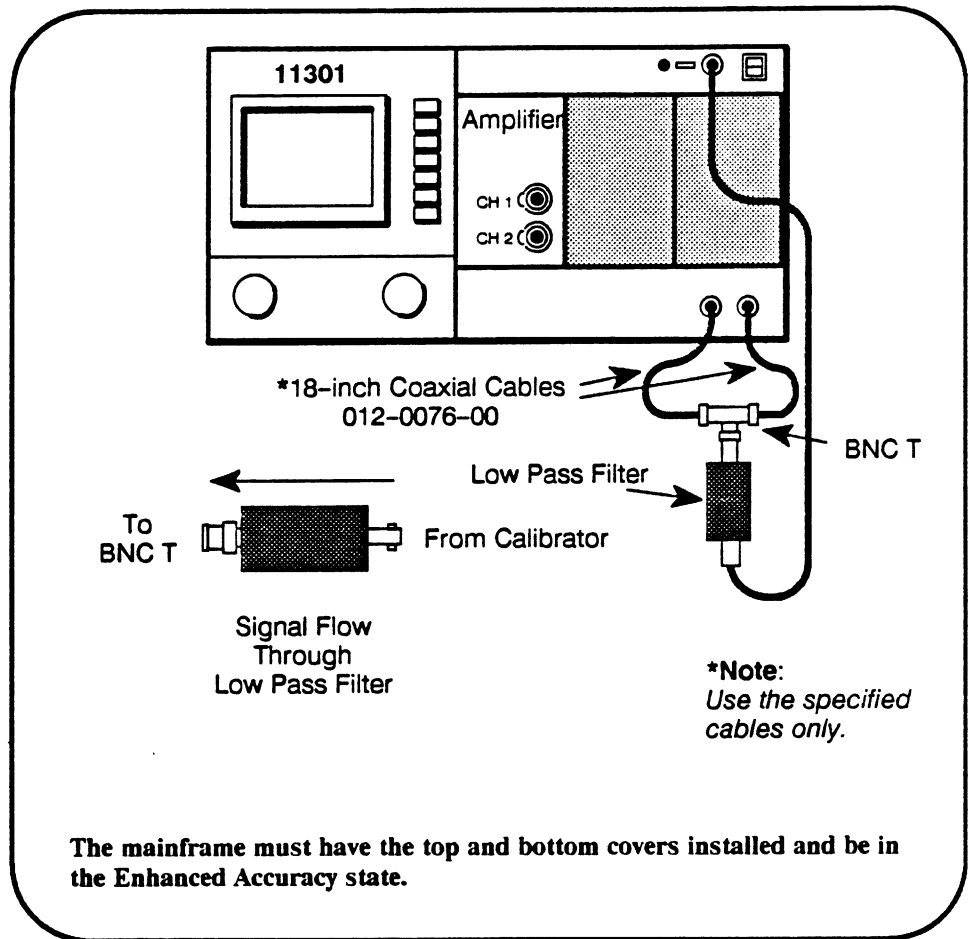

### Procedure

- a. Start the test ext\_ct. Follow the instructions given on the PC.



DO NOT adjust the External Counter Timer Trigger Accuracy if all the verification checks passed. Proceed to the next procedure Part.

---

## Part 34 – Line Trigger

---

### Description

This test checks the range of the trigger level adjustment for a line trigger source.

### Setup

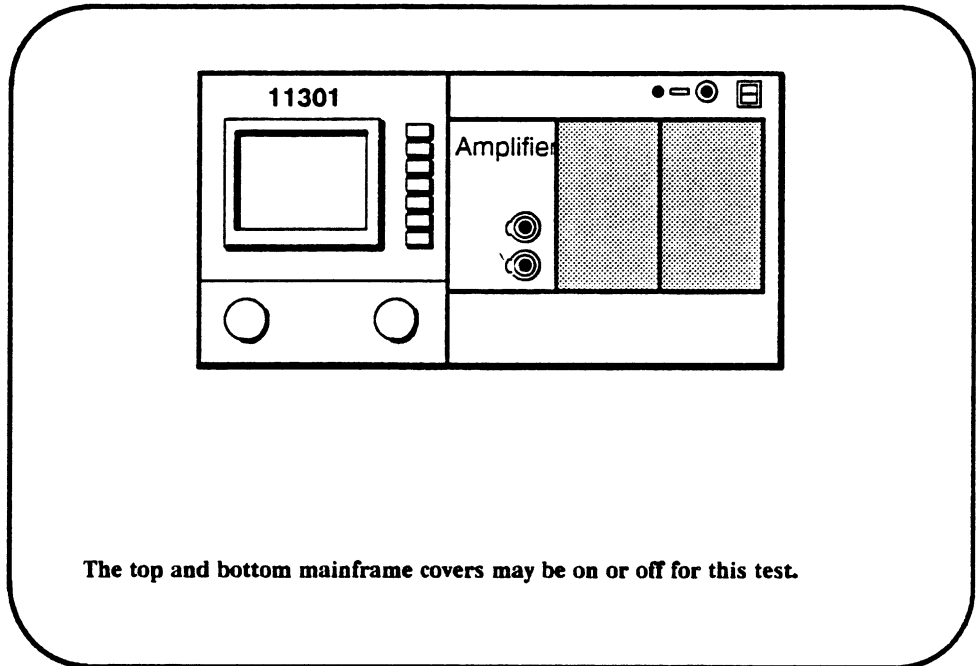

### Procedure

- a. Start the `line_trig` test and follow the PC instructions. Verification is automatic.



DO NOT proceed with adjustment unless the verification phase failed.

# Part 35 – Center Compartment X-Axis Accuracy

## Description

This test checks the accuracy of the X axis gain for the Center compartment.

## Setup

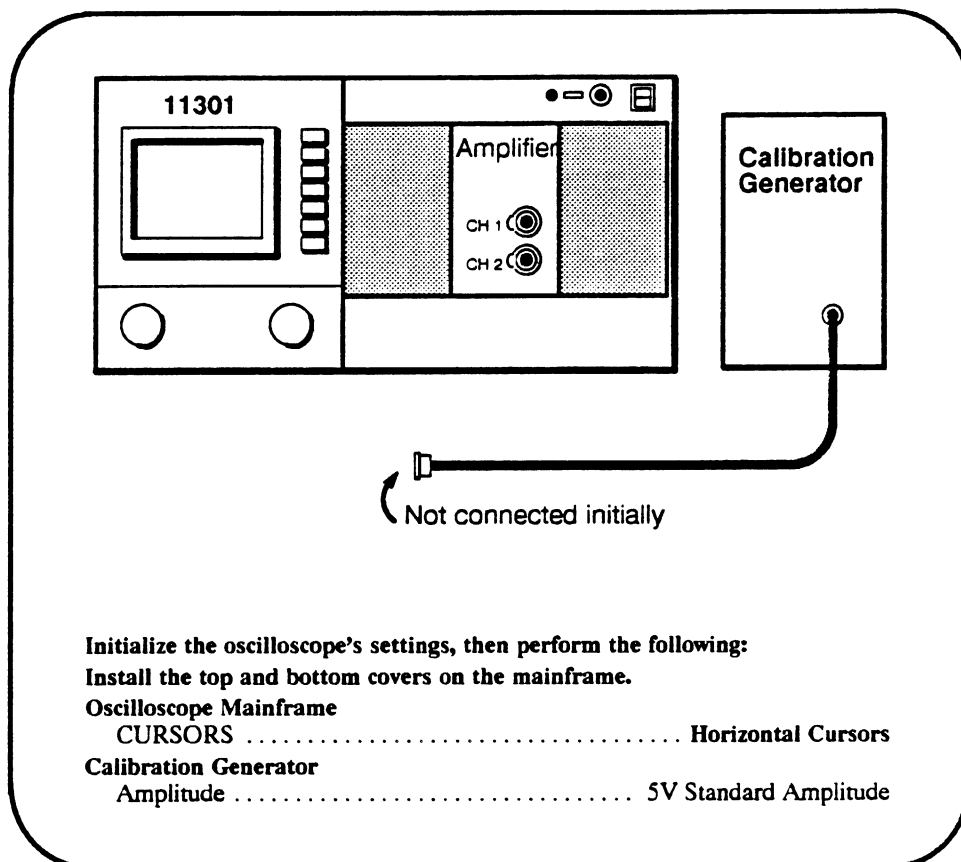

## Procedure

- Press the ENHANCED ACCURACY button twice. The instrument should be properly warmed up before starting the selfcal.
- Press the WAVEFORM button and define an XY trace representing L vs C1.
- Adjust XY INTENSITY to dim the resultant dot waveform to a level low enough to prevent possible crt damage.
- Adjust the reference cursor (left knob) to the center of the dot. Use the FINE knob adjustment.
- CHECK** – that the **Horiz Ref** readout is within specifications of Table 2-12 on the next page.
- Adjust the Horizontal Offset (press the HORIZONTAL DELAY button) to position the dot exactly at screen center.
- Adjust the Horizontal Position to its maximum value (+ 4 divs).
- CHECK** – that the dot is within 0.1 div of the plus fourth graticule.
- Adjust the Horizontal Position to its minimum value (-4 divs).

- j. **CHECK** – that the dot is within 0.1 div of the minus fourth graticule.
- k. Connect the Calibration Generator output to the Plug-In CH1 input.
- l. Use Horizontal Position to center the two dots on the screen.
- m. Re-adjust the reference cursor (left knob) to the center of the left dot, and use the right knob to adjust the other cursor to the center of the right dot.
- n. **CHECK** – that the  $\Delta$ Horiz readout is within the specifications of Table 2-12.

**TABLE 2-12**  
**Horizontal Tolerances**

Plug-In Amplifier Type	DC Balance (Step e.)	$\Delta$ Horiz Accuracy (Step n.)
11A32	$\pm 330$ mV	4.885 – 5.115 V
11A33	$\pm 280$ mV	4.865 – 5.135 V
11A34	$\pm 330$ mV	4.885 – 5.115 V



# Part 36 – Rear Panel Input/Output Signals

## Description

This test checks the functionality of the Rear Panel connectors.

## Setup

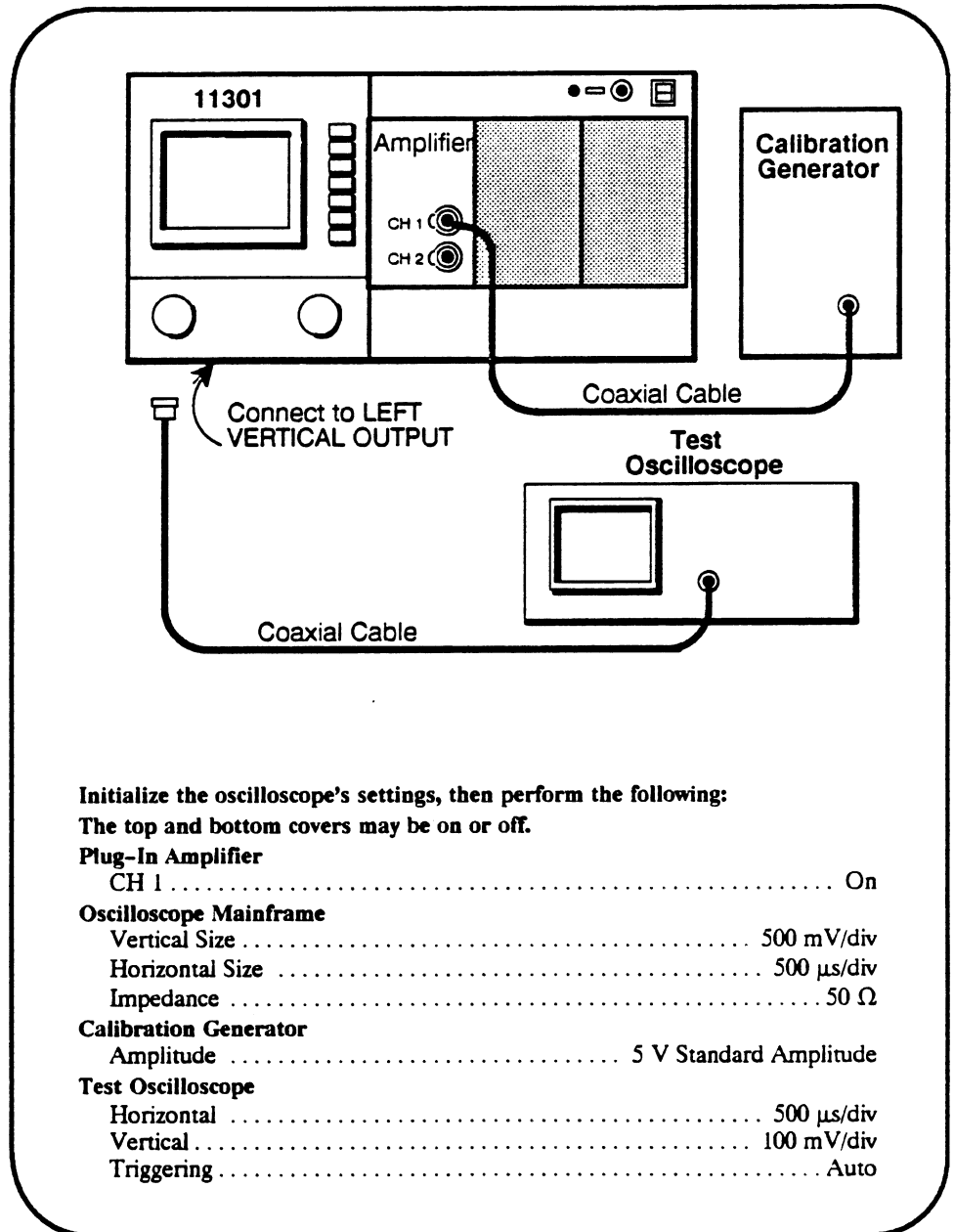

## Procedure

- Use the VERTICAL POS control to center the waveform vertically.
- CHECK**—that the signal displayed on the Test Oscilloscope shows that the bottom of the waveform is within  $\pm 175$  mV of ground.
- CHECK**—that the peak-to-peak amplitude of the signal on the Test Oscilloscope is in the range 450 - 550 mV.

- d. Disconnect the cable from LEFT VERTICAL OUTPUT. Using a BNC T adapter connect the Calibration Generator signal from the back-panel Z AXIS connector to the plug-in CH 1 input.
- e. **CHECK**—that the positive peaks of the signal are blanked on the screen.
- f. Set the Horizontal Size to 1 ms/div.
- g. Remove all cables from the plug-in amplifier and the Z AXIS. Connect a cable from the back-panel MAIN SWP OUT to the Test Oscilloscope. Set the Test Oscilloscope to 1 V/div vertical, 2 ms/div horizontal, 1 M $\Omega$  impedance, auto triggering, and negative slope trigger.
- h. **CHECK**—that the waveform bottom on the Test Oscilloscope is within  $\pm 0.5$  V of ground. **CHECK**—that the slew rate is 0.5 V/ms  $\pm 10\%$ . Over a sweep distance of 4 divisions, the waveform should rise vertically 4 divisions  $\pm 0.4$  divisions.
- i. Remove the cable from the MAIN SWP OUT and connect it to the back-panel SWEEP GATE. Adjust the Test Oscilloscope to normal (not auto) triggering, dc coupling for vertical and trigger signals, and negative trigger slope. Adjust the Test Oscilloscope trigger level to the middle of the range in which triggering occurs.

**NOTE**

*This setup of the Test Oscilloscope will be used in an upcoming step, in which the trigger level adjustment is somewhat difficult. Leave the settings on the Test Oscilloscope as they are through the end of this procedure Part.*

- j. **CHECK**—that the low level of the signal is in the range of 0 - 0.5 V and the high level of the signal is in the range of 2.4 - 5 V.
- k. On the mainframe, set the trigger mode to **Auto** and set the Main Trigger Level to its maximum value (5 V). Select the **2 ns Step Holdoff** and rotate the left knob one click. Observe that the **Holdoff** readout is in the range of 15.999999 - 16.000001 ms.
- l. Select the COUNTER mode of **Period Measure, A Ext Source**. Remove the cable from the Test Oscilloscope and use it to connect the SWEEP GATE to the A EXT INPUT.
- m. Press the TRIGGER button, select **A Ext  $\div 5$**  as the Main trigger source, to set the A EXT INPUT sensitivity. Then select **L1** as the Main trigger source.
- n. Adjust the **CT Ext A** trigger level to 1.500 V.
- o. **CHECK**—that the measured period is in the range of 15.99999 - 16.00001 ms. For Option 1T additional digits will be displayed.
- p. Select **Time TRIGGER HOLDOFF** and select **Off Measure** on the counter. Remove the cable from between the SWEEP GATE and the A EXT INPUT.
- q. Set the Horizontal Size to 10 ms/div.

- r. Connect the BNC cable from the Calibration Generator to the rear-panel TRIGGER RESET connector. Set the Calibration Generator for an Amplitude of 5 V.
- s. **CHECK**—that the mainframe sweep does not traverse the full width of the screen and that the beeper sounds continually.
- t. Connect the rear-panel TRIGGER READY output to the Test Oscilloscope.
- u. Set the Horizontal Size to 1 ms/div. Use the TRIGGER LEVEL menu to establish **Single Mode**.

**NOTE**

*When in **Single Mode** the knobs and buttons will not respond in a normal manner and the mainframe may appear to be “locked up.” Normal operation may be reestablished by removing the TRIGGER RESET signal and touching any button.*

- v. **CHECK**—that the low level of the signal on the Test Oscilloscope is in the range of 0 - 0.5 V and the high level of the signal is in the range of 2.4 - 5 V.

# Part 37 – Counter Reference Clock In/Out

## Description

This test checks the acceptance of the proper frequency range and output of the proper clock signal by the COUNTER REF CLOCK in/out connector on the rear panel.

## Setup

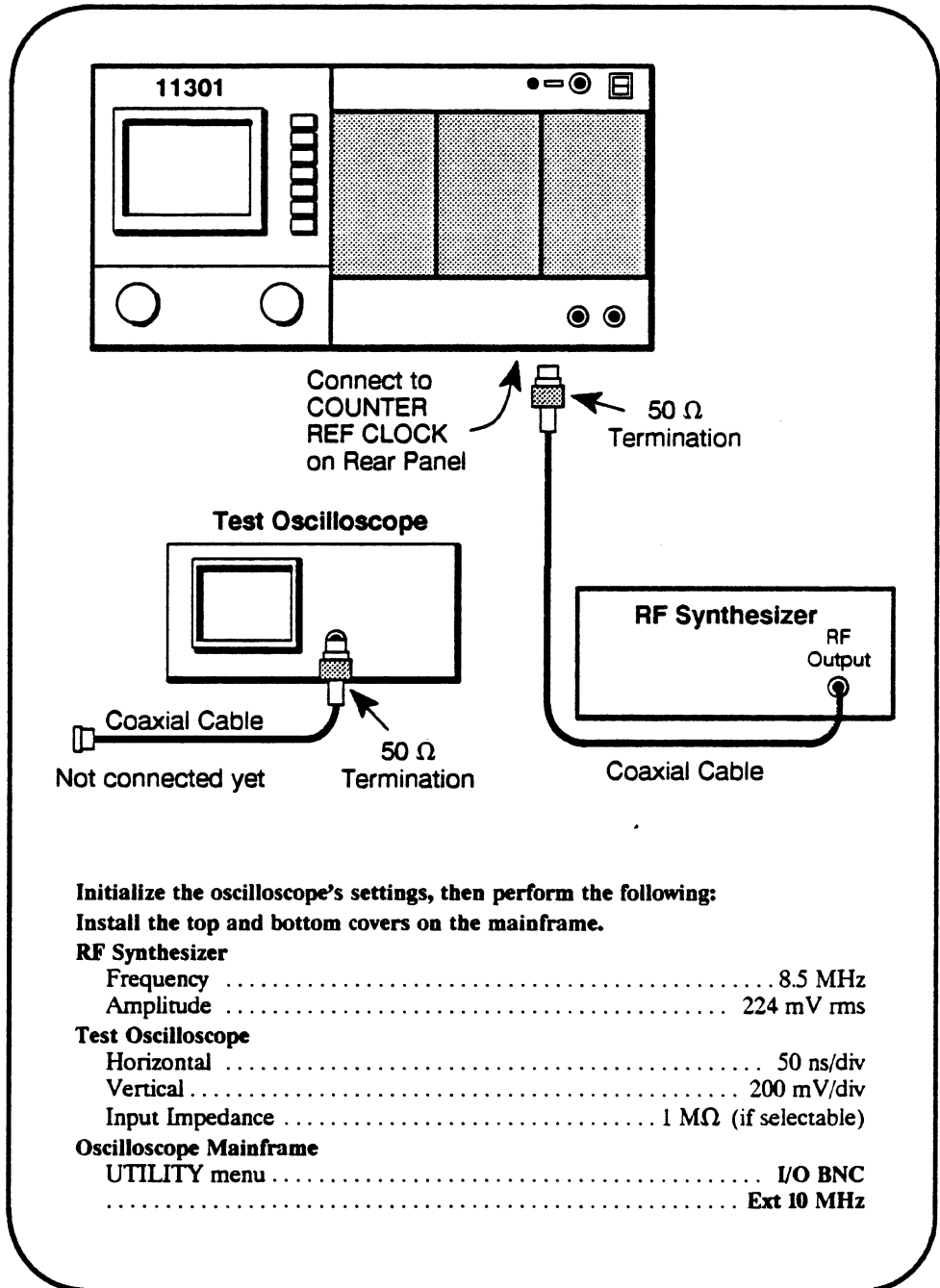

---

**Procedure**

- a. Set the RF Synthesizer to each of the following frequencies and verify that the message **Counter Timer PLL unlocked-check ext ref input** appears on the crt, or not, as indicated below. After each frequency change press the TRIGGER RESET button.

8.5 MHz	PLL Unlocked, message appears
9.9 MHz	PLL is locked, no message
10.1 MHz	PLL is locked, no message
11.5 MHz	PLL Unlocked, message appears
- b. Disconnect the coaxial cable from the COUNTER REF CLOCK connector.
- c. Select **Int** as the mode for the Ref Clock (Utility menu, I/O BNC)
- d. Connect the coaxial cable from the test scope to the rear panel COUNTER REF CLOCK connector.
- e. **CHECK**—that the p-p amplitude on the test scope is at least 500 mV.

# Part 38 – Frequency Accuracy

## Description

This test checks the accuracy of the mainframe frequency measurements with the minimum specified signal amplitude for a plug-in signal source.

## Setup

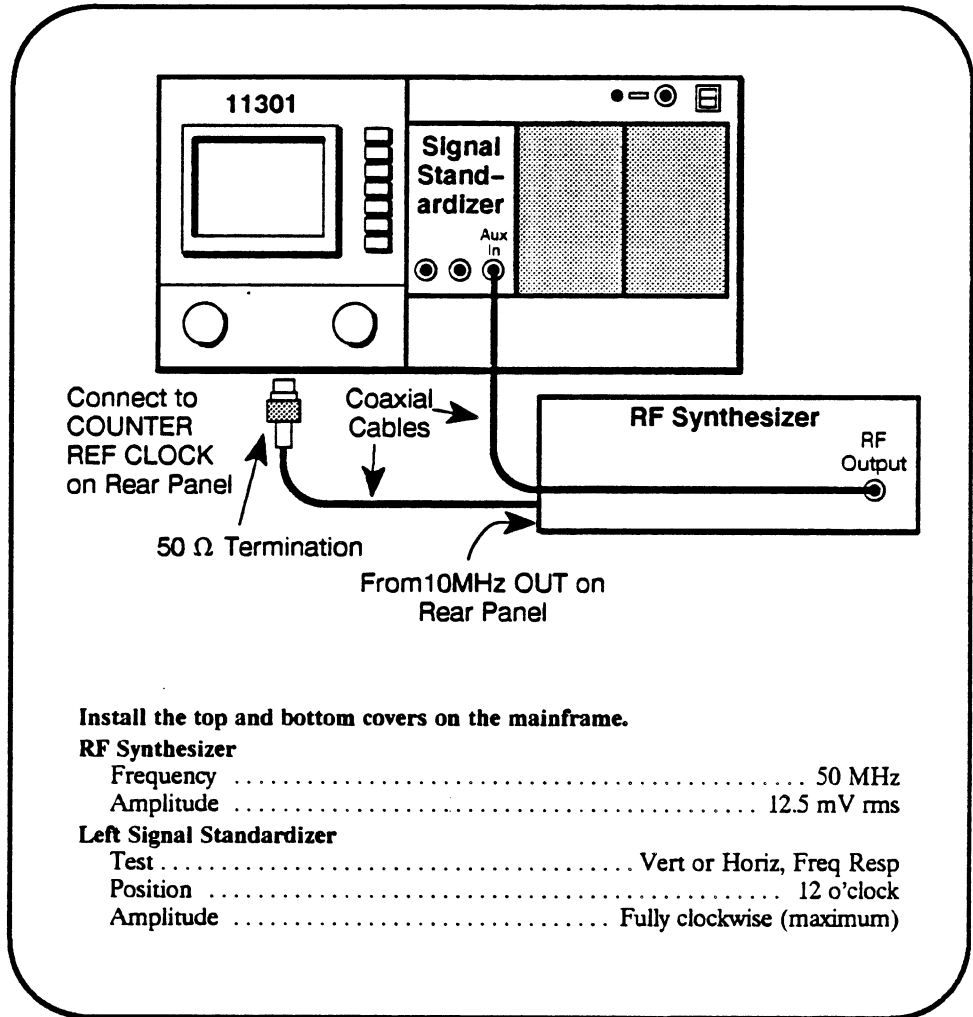

## Procedure

- a. Start test `cal_ct_freq_acc` and follow instructions on the PC. The Main Intensity may need adjustment during the test.

# Part 39 – External A and B Input Sensitivity

## Description

This test checks the sensitivity of the external A and B inputs. Frequency and ratio measurement modes are used in the verification.

## Setup

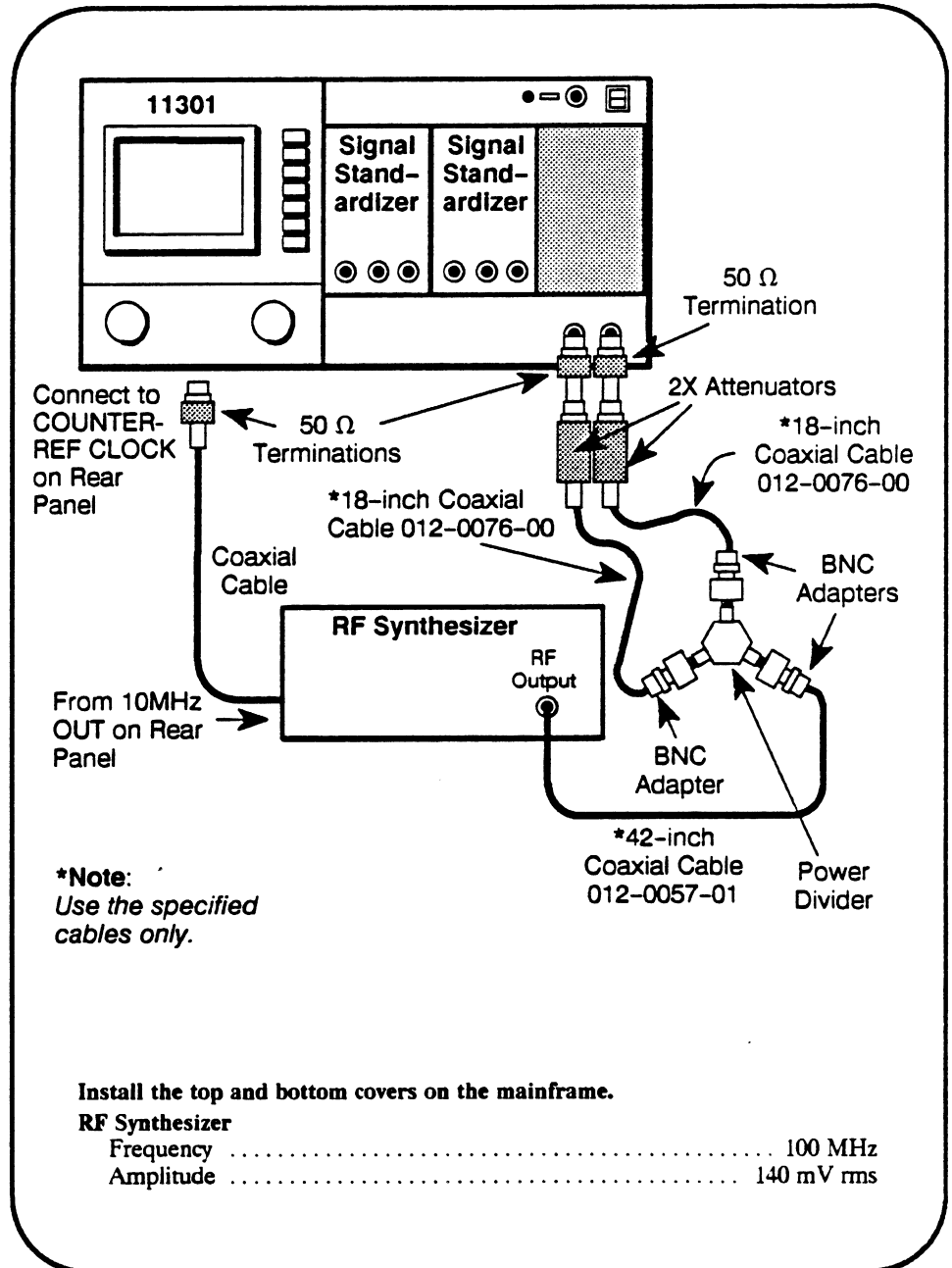

## Procedure

- a. Start the test `cal_ct_sens_ext_r`. Follow the instructions given on the PC.

## Part 40 – 2 ns Holdoff

### Description

This test verifies the agreement between the holdoff settings and the sweep repetition rate.

### Setup

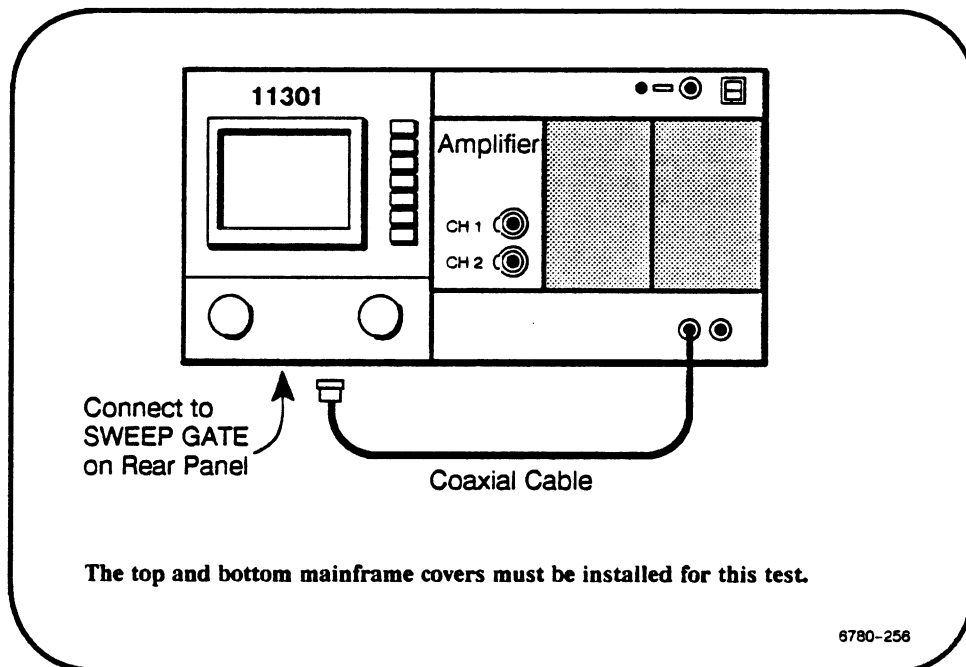

### Procedure

- Start the test `ct_2ns_ho`. Follow the instructions given on the PC.



DO NOT proceed with adjustment unless the verification phase failed.



# Part 41 – Holdoff By Events

## Description

This test verifies that Events Holdoff works at the maximum specified frequencies and that the counter chain toggles correctly with different count values.

## Setup

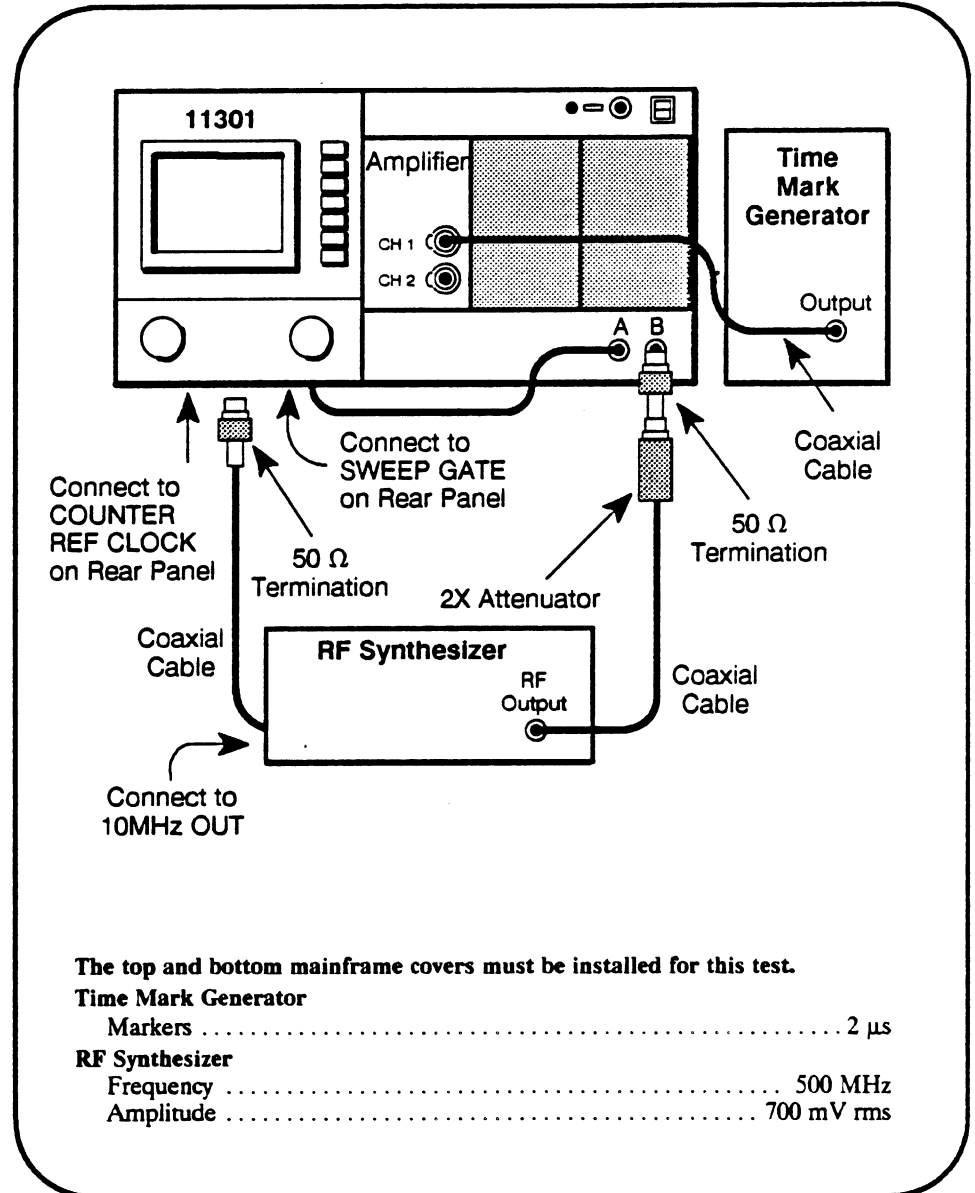

## Procedure

- a. Start the test `holdoff_by_events`. Follow the instructions given on the PC.

## Part 42 – Time Interval Using Sweeps

### Description

This test checks the accuracy of the Time Interval mode of the Counter Timer.

### Setup

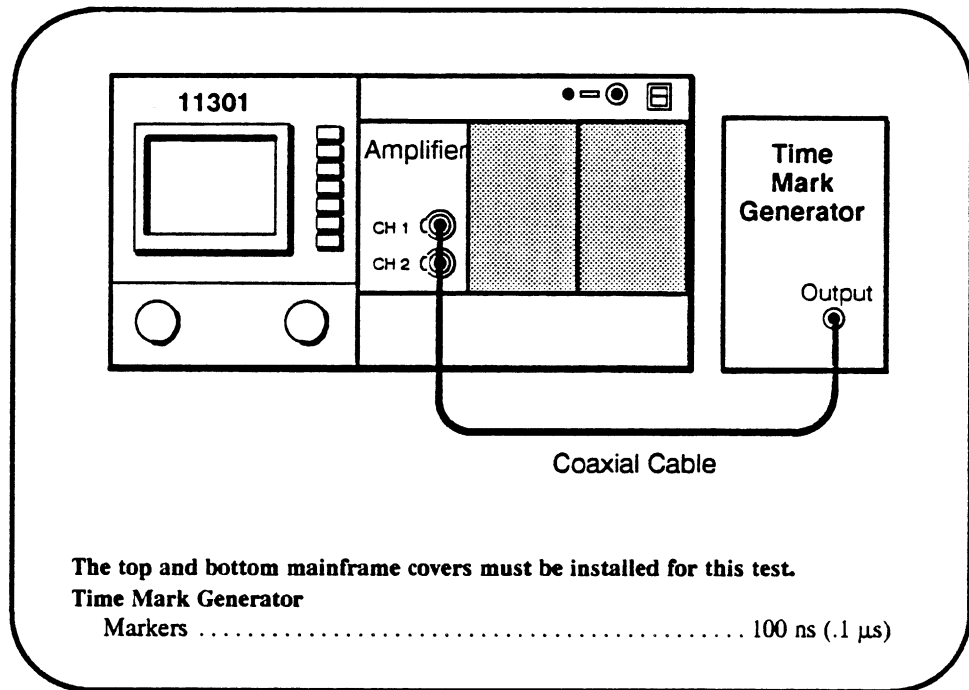

### Procedure

#### *Main to Delayed Time Interval (Runs After)*

- a. Start the test **m\_d\_runs**. Follow the instructions given on the PC.



DO NOT proceed with adjustment unless the verification phase failed.

#### *Main to Delayed Time Interval (Triggered After)*

- c. Start the test **m\_d\_trig**. Follow any instructions on the PC.



DO NOT proceed with adjustment unless the verification phase failed.

- d. When the test **m\_d\_trig** finishes proceed to step e.

#### *Delay 1 to Delay 2 Time Interval (Triggered After)*

- e. Start the test **d1\_d2\_trig**. Follow any instructions on the PC.



DO NOT proceed with adjustment unless the verification phase failed.

# Part 43 – Minimum Time Interval

## Description

This test verifies that the minimum specified width can be measured in the Time Interval mode using the External Inputs.

## Setup

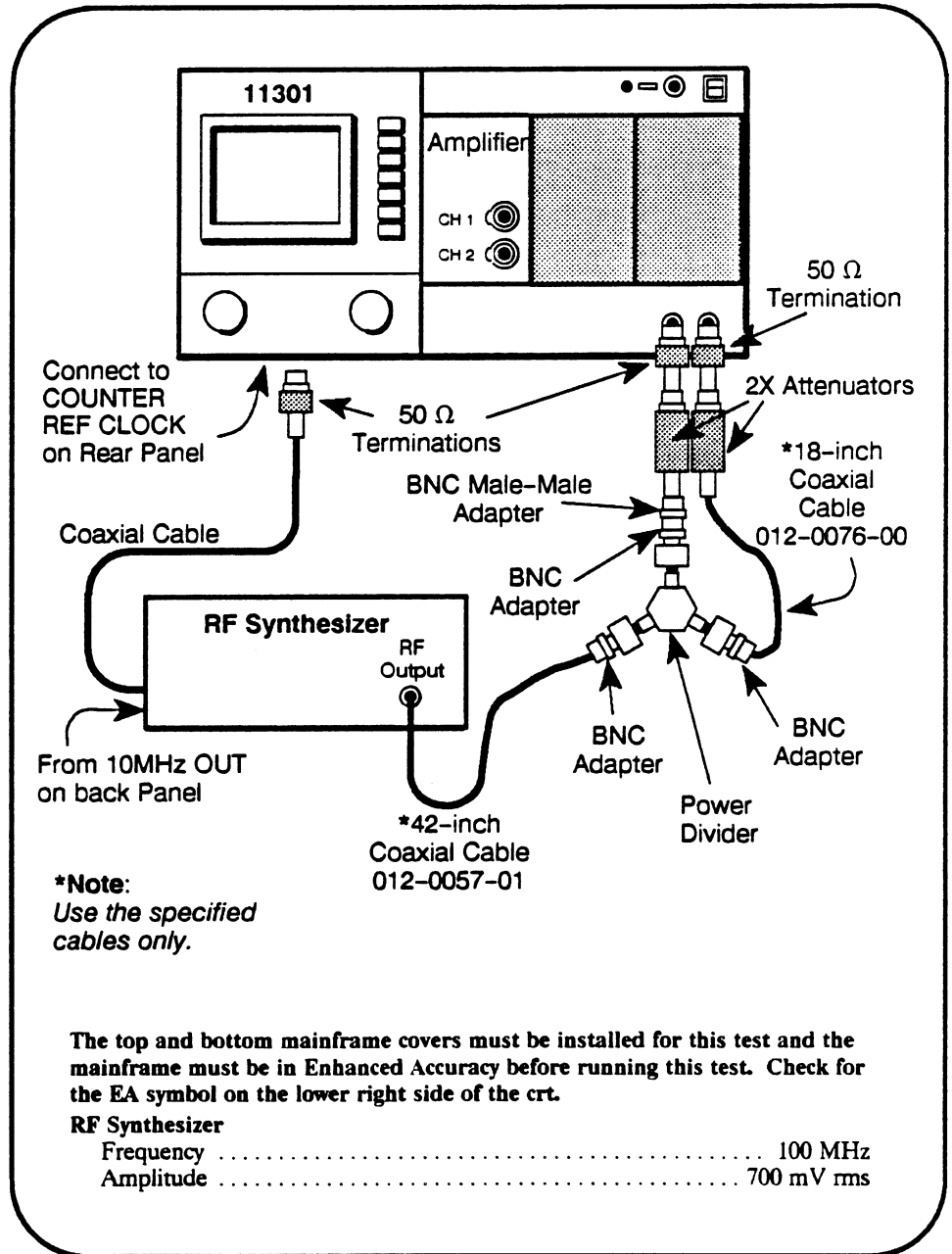

## Procedure

- a. Start the test cal\_ct\_min\_ti. Follow the instructions given on the PC.

---

## Part 44 – Store Cal Constants

---

### Description

This test permanently stores the calibration constants developed in previous procedure Parts. Calibration constants are stored in BBRAM (battery backed-up RAM) during the CATS testing. For reliable operation of the instrument these calibration constants must be moved into the EEROM. The test `save_factory` should be run whenever CATS testing is complete for a mainframe or when you expect a long delay before returning to complete the procedure on a mainframe.

### Procedure



*Do not touch any oscilloscope controls or turn off the instrument during this test. Disturbing the instrument during this test could cause loss of all calibration constant information and a non-functional instrument.*

- a. Start the test `save_factory`. Do not adjust any mainframe control during the test. The PC will indicate test completion.

---

## Part 45 – Reset DIP Switches and Set Time/Date

---

### Description

This procedure Part ensures that the mainframe DIP switches are set to their normal Open position and that the internal clock is working properly. This is the last Part of the Checks and Adjustments procedure.

### Procedure

- a. Remove the top cover if necessary, and set DIP switches 3, 4, and 5 to their Open position (see Fig. 2-1).
- b. Install top and bottom covers, then power-up the mainframe.
- c. Press the **UTILITY** button and select **Time/Date**
- d. Touch **On** under **DATE**. Verify that the date shown in the upper-right corner of the crt is correct. To change the date, use the arrows under **Select** to choose the month or number in the displayed date that you want to change. The selected item is highlighted. Change the selected item using the arrows under **Set**.
- e. When the date is correct, select **12 Hour** or **24 Hour** under **TIME**. Verify that the time shown in the upper-right corner of the crt is correct. The time can be changed in the same manner as the date.
- d. Press the **UTILITY** button again when the time and date are correct.

**THIS COMPLETES THE 11301 CHECKS AND ADJUSTMENTS PROCEDURE**



# Section 3

## Maintenance

---

This section of the manual contains information for performing preventive maintenance and corrective maintenance for the 11301 Programmable Oscilloscope.

---

### Preventive Maintenance

---

Preventive maintenance, performed regularly, can prevent instrument breakdown and may improve the reliability of the instrument. The severity of the environment to which the instrument is subjected will determine the frequency of maintenance. A convenient time to perform preventive maintenance is preceding electrical adjustment of the instrument.

### Cabinet Panel Removal

**WARNING**

*Dangerous potentials exist at several points throughout this instrument. When the instrument is operated with the covers removed, do not touch exposed connections or components. Some transistors have voltages present on their cases. Disconnect power before cleaning the instrument or replacing parts.*

The top and bottom cabinet panels (covers) provide protection from operating potentials present within the instrument. In addition, they reduce radiation of electromagnetic interference from the instrument. Fasteners retain the cabinet panels. To remove the panels, loosen the fasteners and lift the panels off. Operate the instrument with the panels in place to protect the interior from dust.

### Cleaning

The 11301 should be cleaned as often as operating conditions require. Accumulation of dirt in the instrument can cause overheating and component breakdown. Dirt on components acts as an insulating blanket and prevents efficient heat dissipation. It also provides an electrical conduction path which may result in instrument failure. The side panels reduce the amount of dust reaching the interior of the instrument. Keep the side panels in place for safety and cooling.

**CAUTION**

*Avoid the use of chemical cleaning agents that might damage the plastics used in this instrument. Use a nonresidue type of cleaner, preferably isopropyl alcohol or totally-denatured ethyl alcohol. Before using any other type of cleaner, consult your Tektronix Service Center or representative.*

## Exterior

Loose dust accumulated on the outside of the instrument can be removed with a soft cloth or small brush. The brush is also useful for dislodging dirt on and around the front-panel controls. Dirt that remains can be removed with a soft cloth dampened in a mild detergent and water solution. Do not use abrasive cleaners.

## Crt

Clean the crt faceplate with a soft, lint-free cloth dampened with denatured alcohol.

## Interior

Cleaning the interior of the instrument should seldom be necessary. The best way to clean the interior is to blow off the accumulated dust with dry, low-pressure air (such as from a vacuum cleaner). Remove any dirt that remains with a soft brush or a cloth dampened with a mild detergent and water solution. A cotton-tipped applicator is useful for cleaning in narrow spaces, or for cleaning more delicate circuit components.

**CAUTION**

*Circuit boards and components must be dry before applying power to prevent damage from electrical arcing.*

*The high-voltage circuits should receive special attention. Excessive dirt in this area may cause high-voltage arcing and result in improper instrument operation.*



## Visual Inspection

The 11301 should be inspected occasionally for such defects as broken connections, loosely-seated semiconductors, damaged or improperly installed circuit boards, and heat-damaged parts. The corrective procedure for most visible defects is obvious; however, particular care must be taken if heat-damaged parts are found. Overheating usually indicates other trouble in the instrument; therefore, correcting the cause of overheating is important to prevent recurrence of the damage.

## Periodic Electrical Adjustment

To ensure accurate measurements, check the electrical adjustment of this instrument after each 2,000 hours of operation, or every 24 months if used infrequently.

---

## Corrective Maintenance

---

Corrective maintenance consists of component replacement and instrument repair. Special techniques required to replace components in the 11301 Oscilloscope mainframe are given here.

### Power Supply Voltage Hazard

Use caution if working near any metal-faced part in the Power Supply Module.

**WARNING**

*All metal components, including any metal-faced ones, in the Power Supply Module should be considered hazardous. This is because these components are at the AC line voltage potential.*

*Always remove the line power cord before any disassembly.*

*An electric-shock hazard exists when the 11301 is NOT grounded. Do not remove the ground wire (green-yellow) that connects the power supply chassis to the mainframe.*

### Ordering Parts

When ordering replacement parts from Tektronix, Inc., include the following information:

1. Instrument type
2. Instrument serial number
3. A description of the part (if electrical, include circuit number)
4. Tektronix Part Number

## Static-Sensitive Device Classification

**CAUTION**

*Static discharge can damage any semiconductor component in this instrument.*

This instrument contains electrical components that are susceptible to damage from static discharge. See Table 3-1 for relative susceptibility of various classes of semiconductors. Static voltages of 1 kV to 30 kV are common in unprotected environments.

**TABLE 3-1**  
Relative Susceptibility to Damage From Static Discharge

Semiconductor Classes	Relative Susceptibility Levels <sup>1</sup>
MOS or CMOS microcircuits and discrete or linear microcircuits with MOS inputs (most sensitive)	1
ECL	2
Schottky signal diodes	3
Schottky TTL	4
High-frequency bipolar transistors	5
JFETs	6
Linear microcircuits	7
Low-power Schottky TTL	8
TTL (least sensitive)	9

<sup>1</sup>Voltage equivalent for levels.

1 = 100 to 500 V

2 = 200 to 500 V

3 = 250 V

4 = 500 V

5 = 400 to 600 V

6 = 600 to 800 V

7 = 400 to 1000 V (est.)

8 = 900 V

9 = 1200 V

(Voltage discharged from a 100 pF capacitor through a resistance of 100 ohms.)

Observe the following precautions to avoid damage:

1. Minimize handling of static-sensitive components.
2. Transport and store static-sensitive components or assemblies in their original containers, on an anti-static surface, or conductive foam. Label any package that contains static-sensitive assemblies or components.
3. Discharge the static voltage from your body by wearing a wrist strap while handling these components. Servicing static-sensitive assemblies or components should be performed only at a static-free work station by qualified service personnel. We recommend use of the Static Control Mat, Tektronix Part 006-3414-00, and Wrist Strap, Tektronix Part 006-3415-00.
4. Allow nothing capable of generating or holding a static charge on the work station surface.
5. Keep the component leads shorted together whenever possible.
6. Pick up components by the body, never by the leads.
7. Do not slide the components over any surface.
8. Avoid handling components in areas that have a floor or work-surface covering capable of generating a static charge.

---

## Removing and Replacing FRUs

**WARNING**

*To avoid electric-shock hazard and instrument damage, always disconnect the instrument from its power source before removing or replacing FRUs. For plug-in removal or replacement, switch the ON/STANDBY switch to STANDBY.*

The exploded-view drawings associated with the Replaceable Parts List may be helpful in the removal or disassembly of individual FRUs or subassemblies.

The top and/or bottom cover will need to be removed for most repairs. Such removal is not mentioned in each procedure. Since the covers must be removed to locate the individual circuit boards, it is assumed that they are off the instrument. Use a coin or a straight-slot screwdriver with a large size tip to loosen the fasteners. Rotating the fastener a quarter turn counter-clockwise will loosen it.

A small cover fits over the access hole on the side of the plug-in compartment. This access hole is for positioning wire cables inside the mainframe. A Torx screw secures this cover.

Whenever a specific area is mentioned (such as the right side), it will usually be in reference to the front of the 11301. If another reference is intended, it will be so described, (such as the left side, as facing the rear).

**NOTE**

*Refer to "Checks After FRU Replacement" in this section.*

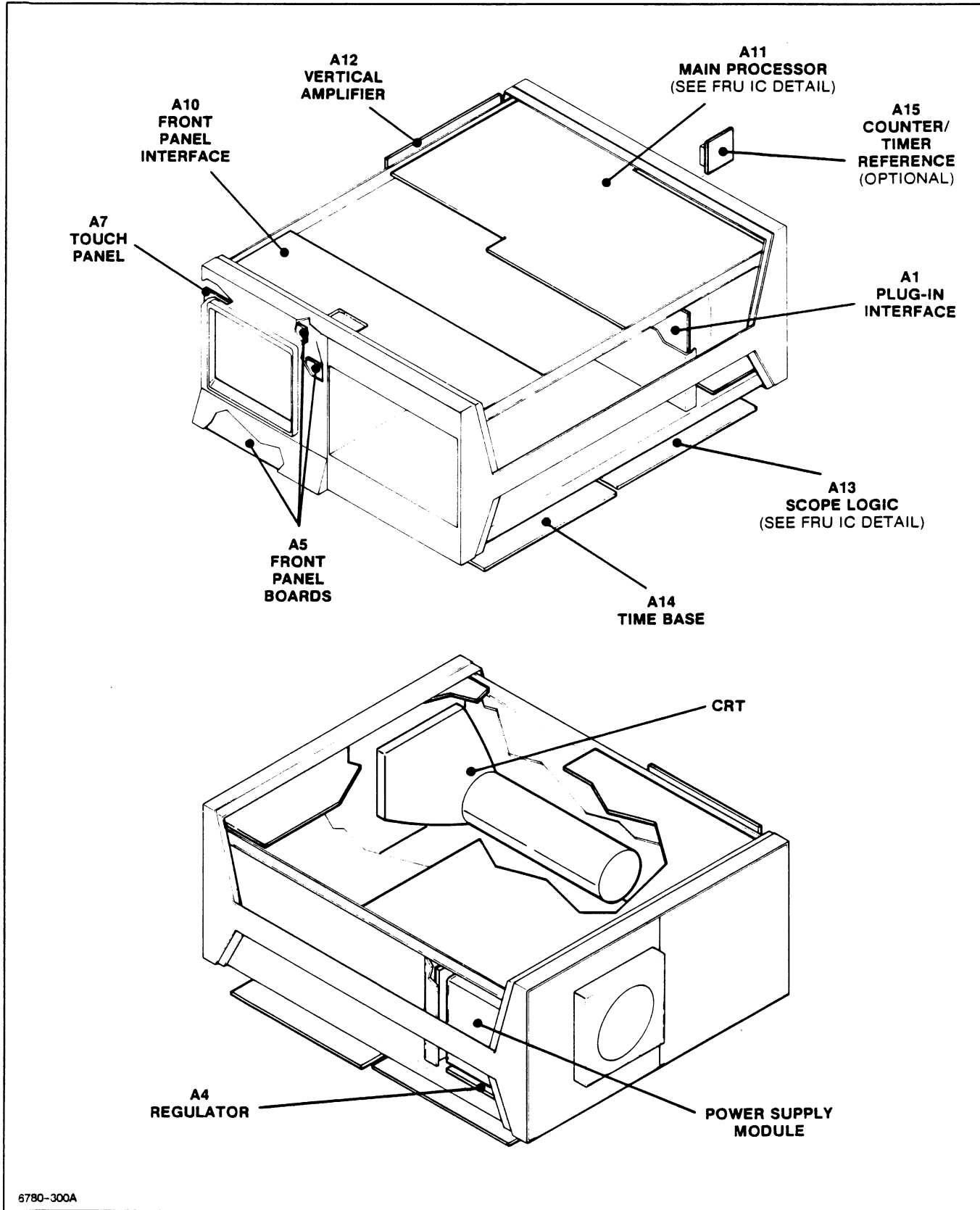
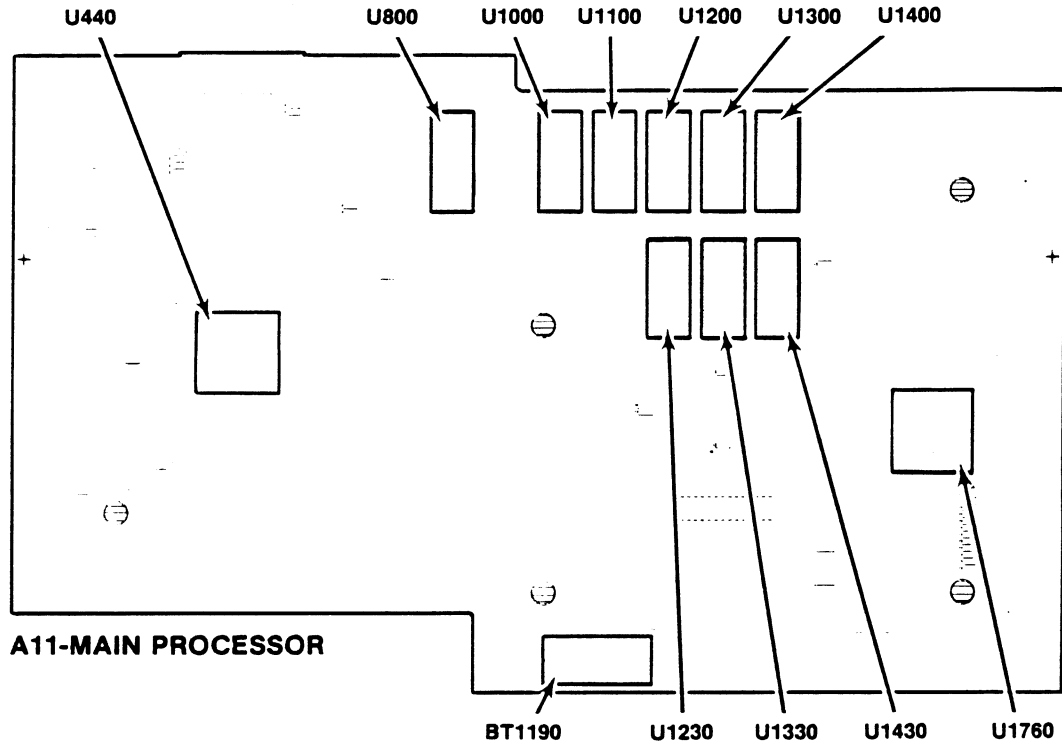
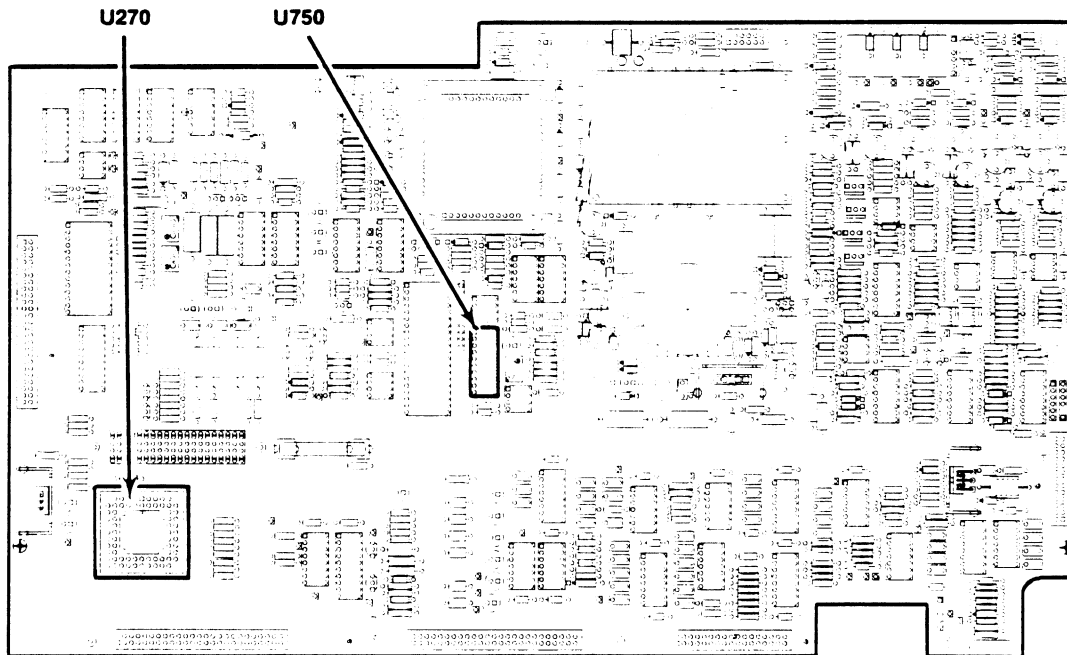

Figure 3-1. Field Replaceable Units (FRU) Locator.

**FRU (FIELD REPLACEABLE UNITS) IC DETAIL**



**A11-MAIN PROCESSOR**



**A13-SCOPE LOGIC**

6780-300B

**Figure 3-1 (cont). Field Replaceable Units (FRU) Locator.**

## Electrical Lock-on of the STANDBY/ON Power Switch

Some applications of the 11301 Programmable Oscilloscope may require that the power remain on. To electrically lock-on the power, proceed as follows:

1. Switch the STANDBY/ON Power Switch to STANDBY.
2. Remove the top cover from the 11301.
3. Locate the A11 Main Processor board as shown in Figure 3-1.
4. Locate and disconnect the J60 connector on the A11 Main Processor board (see Fig. 3-10).
5. Install a jumper (Tektronix Part 131-0993-00) over the front two pins where the J60 connector was located.



*The power will now remain on regardless of the setting of the STANDBY/ON Power Switch.*

*Do not remove or reinstall a plug-in unit while the power is on. Doing so may damage the mainframe and the plug-in.*

6. To turn off the power while the J60 jumper is in place, use the PRINCIPAL POWER SWITCH (on the rear panel).

To return to normal operation of the ON/STANDBY Power Switch, follow the preceding steps in reverse order.

An alternate procedure to electrically lock-on the power is as follows:

1. Switch the PRINCIPAL POWER SWITCH (on the rear panel) to OFF. Remove the AC power cable.
2. Position the 11301 on its left side (handle).
3. Remove the bottom cover from the instrument.
4. Locate the A4 Regulator board and the A13 Scope Logic board as shown in Figure 3-1.
5. Locate and disconnect the J71 connector from its holder on the A13 Scope Logic board. (See Fig. 3-13.)
6. Locate the J820 jumper on the A4 Regulator board. (See Fig. 3-6.)
7. Carefully lift the plastic protector located underneath the J71 cable.

### NOTE

*This protector can be bent slightly to reach the J820 jumper.*



8. Reposition the J820 jumper from its two outer pins (right side) to its two inner pins (left side). Try not to drop the jumper while moving it.
9. Reconnect the AC power cable and move the PRINCIPAL POWER SWITCH to ON.



*The power will now remain on regardless of the setting of the STANDBY/ON Power Switch.*

*Do not remove or reinstall a plug-in unit while the power is on. Doing so may damage the mainframe and the plug-in.*

10. To turn the power off while the J820 jumper is on the inner pins, use the PRINCIPAL POWER SWITCH.

To return to normal operation of the STANDBY/ON Power Switch, follow the preceding steps in reverse order.

## Power Supply Module Removal

The power supply can be slid out of the rear of the 11301 for maintenance and troubleshooting. It may also be removed to gain better access to the A1 Plug-In Interface board, or the A4 Regulator board.

To remove the Power Supply Module from the mainframe, proceed as follows:

1. Turn the mainframe on its left side (as viewed facing the rear panel). The Power Supply Module will now be at the bottom of the instrument.
2. Remove the eight Torx screws that secure the Power Supply Module (see Fig. 3-2).
3. Carefully pull the Power Supply Module part way out of the mainframe. Stop before the wires (to the A2A2 Control Rectifier board connectors) begin to stretch taut or bind.

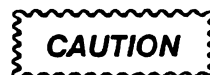

*Excessive pulling on the power supply beyond this point may damage the connector pins.*

### NOTE

*Record the connectors' locations for correct replacement. (See Fig. 3-3.)*

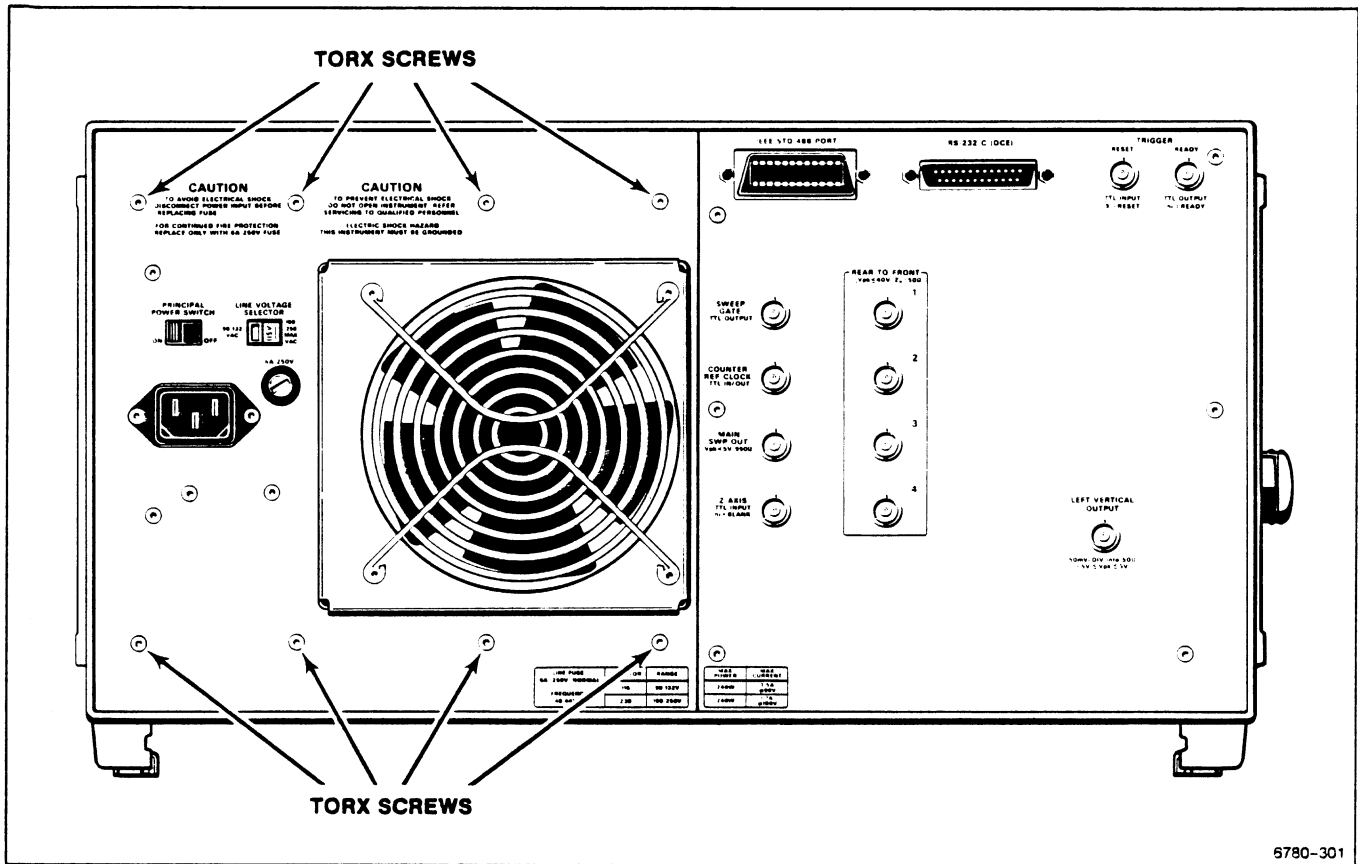

5780-301

Figure 3-2. Rear panel location of screws securing the Power Supply Module.

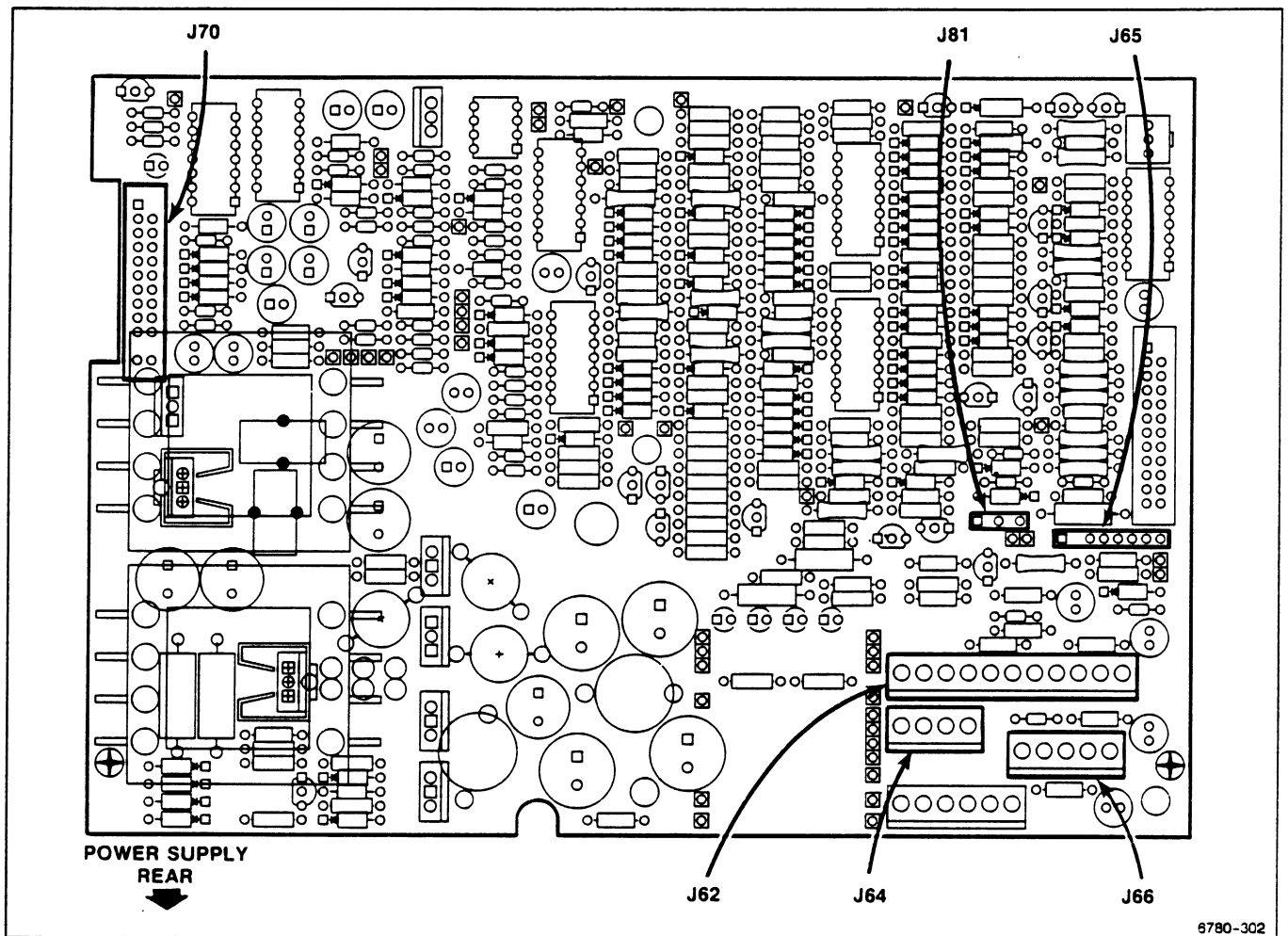

Figure 3-3. Bottom view of the A2A2 Control Rectifier board showing connector locations.

4. Remove the wire connectors from their pins on the A2A2 Control Rectifier board.
5. Remove the chassis ground (green-yellow) wire.
6. Remove the Power Supply Module.
7. To replace the Power Supply Module, follow the previous steps in reverse order.

#### NOTE

*Align the metal guides on the top of the power supply with the plastic grooves inside the upper part of the opening in the mainframe.*

*Be careful not to pinch any wires or interconnecting cables while installing the Power Supply Module.*

## Fan Motor Removal

Remove and replace the fan motor as follows:

1. Using a pencil or tape, mark the top of the fan motor housing. (It reassembles only one way.) Remove the four screws holding the assembly together.
  - Hold the housing as the last screws are removed.
2. Separate the grill and the housing from the motor.
3. Remove the two wires at their motor connections.
  - Note that the red wire is (+) and the brown wire is (-).

### NOTE

*Observe the position in which the motor is mounted. Replace it the same way, or the fan wires may not reach.*

4. Remove the fan motor.
5. To replace the fan motor, follow the removal procedure in reverse order.
  - Don't pinch the wires under the fan housing.
  - Tighten the screws securely. Remove the mark from the top of the housing.
  - Check that no wires contact the fan blades.

## Cathode-Ray Tube Removal

Remove the cathode-ray tube (crt) as follows:

### WARNING

*The crt may retain a dangerous electrical (20 kV) charge. Before removing the crt, the anode must be fully discharged. Short the anode lead from the crt to the chassis. Wait approximately ten minutes and again firmly short this lead to the chassis. Remove the crt. Then, an hour after the lead was first discharged, ground it again by touching it to the black conductive coating on the crt.*

*If 24 hours elapse between crt removal and replacement, ground the anode lead by touching it to the black conductive coating on the crt.*

*Use care when handling. Breakage of the crt causes a high-velocity scattering of glass fragments (implosion). Protective clothing and safety glasses should be worn. Avoid striking the crt on any thing that might cause it to crack or implode.*

*When storing a crt, place it in a protective carton. Otherwise, set it face down in a protected location. Be certain it is on a smooth surface with a soft mat under the crt faceplate.*

1. Position the 11301 with its right side down. Remove its top and bottom covers. Remove the access hole cover from the inner side of the left plug-in compartment.
2. Remove the six Torx screws from the rear panel plate. Allow the plate to remain suspended from its wires.
  - Protect the surfaces underneath the plate from scratches.
3. Loosen the four Torx screws (do not remove) on the crt rear retaining ring.
  - Remove the clear plastic protective cover from over the left rear corner of the A13 Scope Logic board.
  - Remove the J53 connector.
4. Open the clasp on the cable retainer that holds the J53 cable, the anode lead, and the crt base-pin socket cables.
  - Remove the J53 cable and the anode lead from the cable retainer.
  - Remove the anode lead from its keyhole recess. (The recess is part of the crt support between the crt base-pin socket and the bottom of the mainframe.)

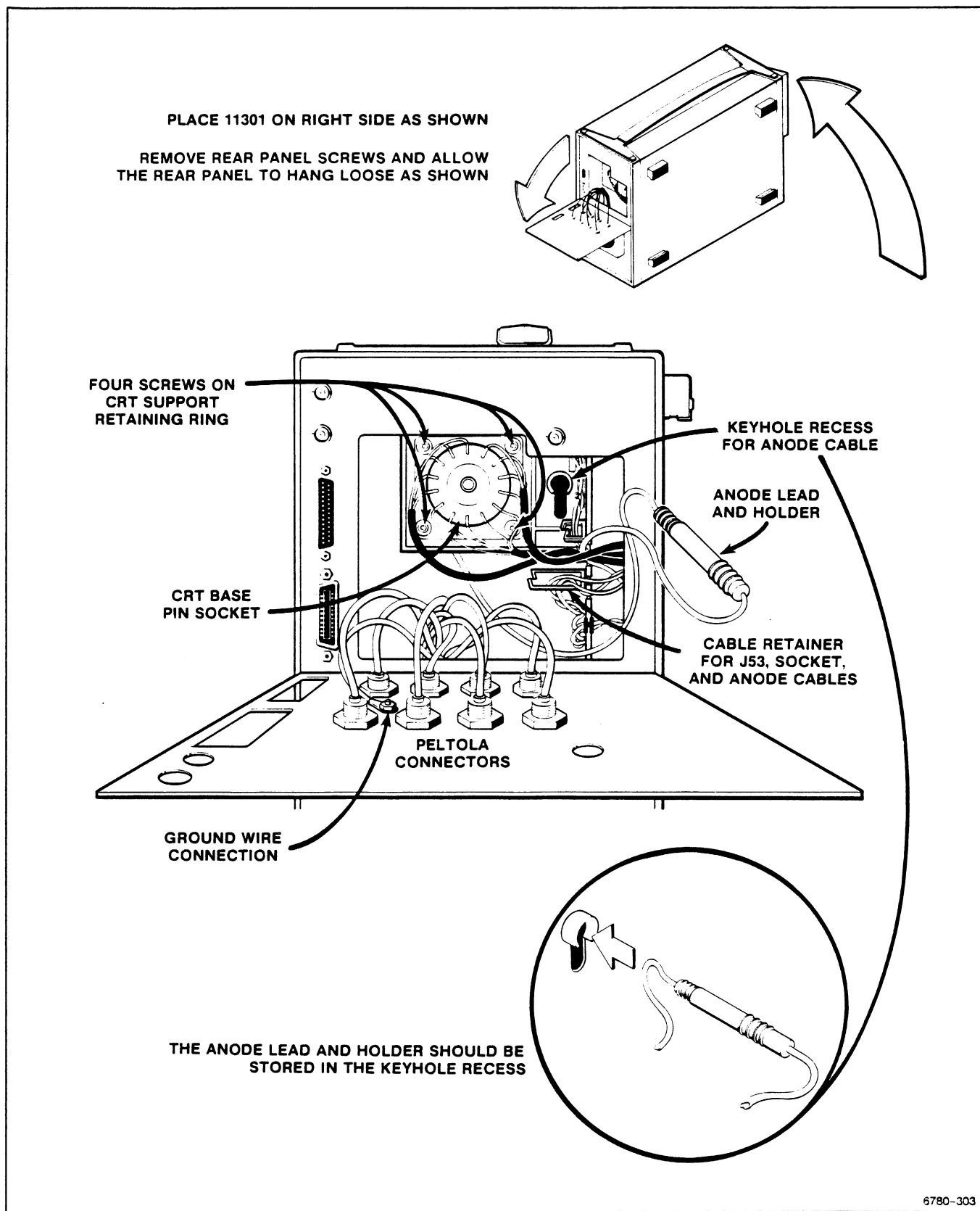

Figure 3-4. Rear view of crt base-pin socket and inside view of rear panel.

**WARNING**

*The crt anode voltage is 20 kV. Ground the anode to the chassis to discharge any stored charge remaining in the crt.*

*Wait ten minutes and ground the anode lead again.*

5. Disconnect the anode lead from its holder. Ground the anode to the chassis, as in the preceding instructions.

**WARNING**

*Ground the anode lead again one hour after the lead was first discharged. If 24 hours elapse between the removal and replacement of the crt, ground the lead by touching it to the black conductive coating on the crt.*

6. Disconnect the crt base-pin socket. Install a protective cap, if available, over the pins.
7. Remove the A7 Touch Panel board, which retains the crt. Refer to the circuit board removal procedures in this section.
8. Disconnect all six crt neck pin leads. Use care to avoid damaging the neck pins.
  - Two leads connect to the A12 Vertical Amplifier board.
  - Two leads connect to the passive network (crt termination resistor).
  - Two leads connect to the A14 Time Base board.
9. Remove the crt by sliding it slowly through the front. Check that the anode lead and the J53 cable are trailing the crt.
  - Guide the base-pin sockets as far outward as possible.
  - Pull the anode lead and the J53 cable through the grommet inside the crt shield.

**NOTE**

*The rubber pads in the front casting (at the corners of the crt faceplate) may fall out. Reinstall them if necessary.*

## Cathode-Ray Tube Replacement

### NOTE

*Before replacing the crt, check that the grid scale numbers are on the left and the "Tek" logo is on the right of the faceplate.*

Replace the crt as follows:



*The crt anode lead may need to be grounded before replacing the crt. If more than 24 hours have elapsed since the crt was removed, ground the anode lead to the black conductive coating on the crt.*

1. Route the anode lead and the J53 cable through the grommet (at the bottom inside right of the crt shield). Push the crt into place while routing the cables.

### NOTE

*Pull the cables through the rear of the 11301 so that they do not tangle inside the crt shield.*

*The base-pin socket may need to be moved around to insert the crt base into the retaining ring.*

2. Reinstall the A7 Touch Panel board. Use the procedure to replace the A7 Touch Panel board in the "Circuit Board Removal" section.



*Tighten the crt scale cover screws only with a diagonal method. DO NOT TIGHTEN IN A CLOCKWISE DIRECTION. This method will damage the corner of the crt faceplate.*

*For instructions on this diagonal method, read the CAUTION notice listed at the end of the A7 Touch Panel board removal (and replacement) procedure, in this section.*

### NOTE

*Check that the implosion shield and the lens frame are correctly seated.*

- Position the instrument on its right side.
3. Reconnect all six crt neck pin leads. Do not bend the neck pins.



4. Tighten the four screws around the crt rear retaining ring.
  - Remove the protective cap and reinstall the crt base-pin socket.
  - Reinstall the anode lead and the J53 cable into the cable retainer. Close the retainer's clasp.
5. Route the J53 cable through the middle grommet. Dress the J53 cable along the edge of the A13 Scope Logic board.
  - Reconnect the J53 connector to the A13 Scope Logic board.
  - Reinstall the clear plastic protective cover.
6. Reconnect the anode lead to its holder.
7. Put the anode lead and holder into the keyhole-shaped recess. See Figure 3-4. (The anode lead and holder fit into the round hole while the cable fits into the slot alongside it.)
8. Check that all cables are placed inside the grommets.
  - Check that all Peltola connectors (inside the rear panel plate) are connected to their BNC sockets.
9. Replace the rear panel plate. Reinstall and tighten all six Torx screws.
10. Reinstall the access hole cover on the side of the left plug-in compartment. Secure it with a Torx screw.
11. Replace the top and bottom covers.

**NOTE**

*Refer to "Checks After FRU Replacement" in this section.*

## Lithium Battery Disposal and First Aid

A lithium battery (BT1190) is mounted on the A11 Main Processor board. See Figure 3-10.

### Removal and Handling

Remove the battery by grasping it between your thumb and fingertips. Pull it from its mounting bracket.

Do not drop the battery. Short circuits or other problems can be caused by dropping.

Do not place the battery on any metal surface.

#### **WARNING**

*To avoid personal injury, observe proper procedures for the handling of lithium batteries. Improper handling may cause fire, explosion, or severe burns. Do not recharge, crush, disassemble, heat the battery above 100° C (212° F), incinerate, or expose the contents to water.*

### Storage

When storing a battery, separate it from all conductive or metal surfaces. Do not store batteries loosely nor dump them into bins.

Store them in their original shipping container or individually wrapped in plastic.

### Board Cleaning

If present, battery salts will usually appear as a white powder upon contact with a circuit board. These salts may react with one or more layers of the board material, resulting in permanent damage and/or open traces.

Clean the salts from the board immediately with a brush and water. Any boards that were in contact with battery salts (for more than a few minutes) must be thoroughly tested for possible damage.

## Disposal

Dispose of the Lithium battery in accordance with local, state, and federal regulations.

Typically, small quantities (less than 20) can be safely disposed of with ordinary garbage in a sanitary landfill.

Larger quantities must be sent by surface transport to a Hazardous Waste Disposal Facility. The batteries should be individually packaged to prevent shorting. Then, pack them into a sturdy container that is clearly labeled, “**Lithium Batteries – DO NOT OPEN**”.

## Replacement

Check the (+) polarity on the replacement battery matches the (+) mark on the circuit board. Replace the battery by inserting it into its mounting bracket.

## Emergency & First Aid Information

<b>Manufacturer:</b>	<b>Panasonic</b>
<b>Battery Type:</b>	<b>Lithium Poly–Carbon monoflouride, BR 2/3 A</b>
<b>Solvent (electrolyte):</b>	<b>Gama Butyrlactone</b> is of low toxicity. It can cause some eye and respiratory irritation. The solvent may be released during venting, according to the manufacturer. (Venting is an out gassing of battery material.) This is usually caused by short circuiting (for more than a few seconds) or by overheating.
<b>Solute:</b>	<b>LIBF4</b>
<b><u>Should you come in contact with battery solvent</u></b>	
<b>By:</b>	<b>Do This:</b>
<b>Contact with skin</b>	Wash promptly with plenty of water.
<b>Contact with eyes</b>	Flush immediately with plenty of water and use an emergency eye wash, if available. Report to a medical professional for treatment.
<b>Inhalation</b>	Leave the area and get fresh air. Report to a medical professional for treatment.
<b>Ingestion</b>	Non-toxic according to laboratory testing. However, report to a medical professional for advice.

**In case of venting, clear the immediate area.** Venting will usually last only a few seconds.

## Front Panel Assembly Removal

Remove the Front Panel Assembly as follows:

1. Set the 11301 up on its right side. Remove the top and bottom covers. Remove the access hole cover from the inner side of the plug-in compartment.
2. Pull off the Intensity Control knob. Remove the 7/16-inch nut and washer from its shaft.
3. Disconnect the J57, J73, J74, and J76 connectors from the A10 Front Panel Interface board. See Figure 3-9.
4. Remove the 1/4-inch nut from behind the top left corner of the front casting.

### NOTE

*Removal of the J72 connector from the A10 Front Panel Interface board can help to reach this nut.*

5. Remove the two Torx screws from behind the bottom left of the front casting.
6. Set the 11301 right side up.
7. Pull the Front Panel Assembly out until its bottom clears the front casting. Move its top outward about three inches away from the casting.
  - Withdraw the J73 cable, via the access hole, through the upper chassis plastic channel and its slot in the front casting.
  - Withdraw the J74 cable, via the access hole, through the upper chassis plastic channel and its slot in the front casting.
  - Remove the J76 cable through the front casting.

To replace the Front Panel Assembly, follow the previous steps in reverse order.

## Circuit Board Removal

All of the circuit boards in the 11301 are mounted on the chassis. Pin connectors are used for electrical interconnection with chassis-mounted components and other circuit boards.

To determine the location of a circuit board, see the view in Figure 3-1.



*After removing a circuit board from the instrument, place it upon a non-conducting surface. This will minimize the chance of static charge damage to the integrated circuits and/or related circuitry.*

Some parts mounted on a board must be retained for use with the new assembly. These parts might include interconnecting plugs, support posts, and some wiring.

### NOTE

*Refer to "Checks After FRU Replacement" in this section.*

## A1 Plug-In Interface Board

Remove and replace the A1 Plug-In Interface board as follows:

1. Set the 11301 right side up. Remove its top cover.
2. Remove the plug-in units.
3. Remove the nine Torx screws securing the interface connector receptacles to the chassis. See Figure 3-5.
4. Disconnect all connectors from the A11 Main Processor board. See Figure 3-10. Note the position of their index triangles so that the connectors can be correctly replaced.
  - Remove the five board-retaining Torx screws.
  - Remove the mounting posts from the RS-232-C and GPIB connectors on the rear panel. Move the plastic cable protector flange off the right side of the chassis.
  - Gently remove the A11 Main Processor board by lifting it.

### NOTE

*The J90 interconnecting pins from the A1 Plug-In Interface board hold the board firmly. Lift the board carefully so that neither this connector nor the A11 Main Processor board is damaged.*

*A plastic pin guide covers the Plug-In Interface connector underneath the A11 Main Processor board. This guide may come off when the board is removed. Replace the pin guide if it does come off.*

5. Remove the Power Supply Module. See "Power Supply Module Removal" in this section.
  - Remove the connectors (except for J81) from the A2A2 Control Rectifier board.

**NOTE**

*Record the locations of the connectors to replace them correctly.*

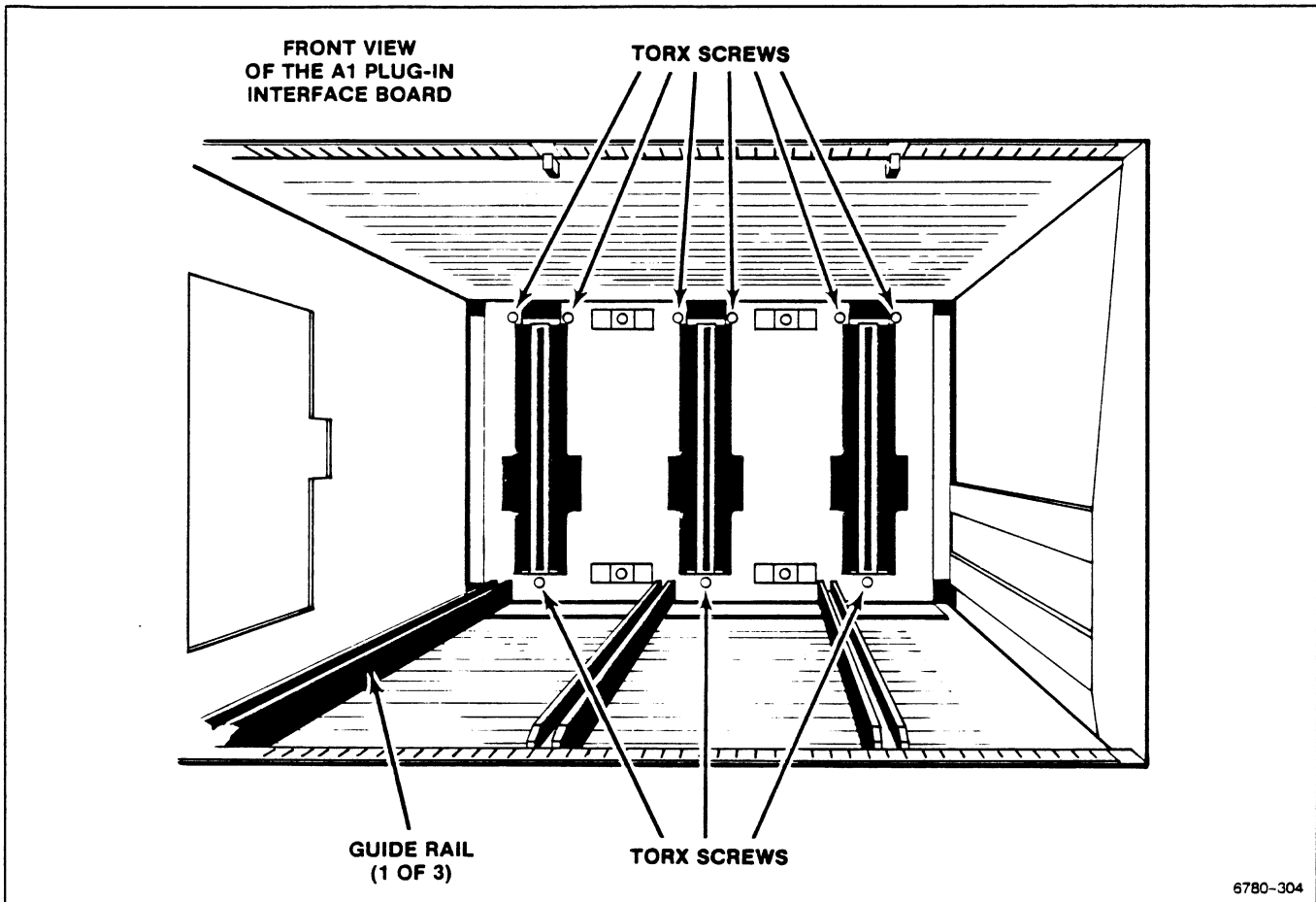

**Figure 3-5. Plug-in compartment showing mounting screws for the A1 Plug-In Interface board.**

6. Disconnect the J57 connector from the A4 Regulator board (see Fig. 3-6).

**NOTE**

*If the (optional) A15 Counter/Timer Reference Board is installed, disconnect the J40 connector. (See Fig. 3-6.)*

- Remove the two Torx screws from the metal heatsink at the rear of the board. There are holes provided in the chassis, across from these screws, to insert a screwdriver.

**NOTE**

*The A4 Regulator board is now unfastened from the chassis. However, it is still connected to the A1 Plug-in Interface board.*

- Carefully disconnect the J95 and J96 interconnecting pins from the A1 Plug-In Interface board by pulling the A4 Regulator board towards the rear.
  - Remove the A4 Regulator board.
7. Position the 11301 on its right side and remove the bottom cover.
  8. Disconnect the A13 Scope Logic board, see “Circuit Board Removal” in this section. The cables from the board to the crt do not need to be completely removed from the rear panel area. Allow the board to remain suspended from the chassis.
  9. The A1 Plug-In Interface board can be removed from either side of the chassis.

**NOTE**

*Mark each of the wire connectors so that they can be correctly replaced.*

- Cut the three plastic cable tiedowns attached to the bottom of the board. These tiedowns keep the wires separated between the connector receptacles.
- Remove the J64 cable (from the A2A2 Control Rectifier board) through the chassis opening beside the A1 Plug-In Interface board. Remove the Peltola connectors from the A1 Plug-In Interface board.
- Remove the A1 Plug-In Interface board.

To replace the A1 Plug-In Interface board, follow the previous procedure in reverse order. Additional instructions follow:

1. Reconnect the Peltola connectors to the board.

**NOTE**

*Replace the three plastic cable tiedowns to the bottom of the A1 Plug-In Interface board.*

- Return the J64 cable through the chassis opening to where the A2A2 Control Rectifier board will be installed.
- Check that the plastic pin guides remain attached to the connectors on each side of the A1 Plug-In Interface board.
- Reinstall the nine Torx screws when the board is replaced to the instrument. Tighten all the screws.

**CAUTION**

*The (black) plug-in guide rails (see Fig. 3-5) must touch the chassis by the A1 Plug-In Interface Connector receptacles. If these guide rails have been removed or moved out of position, realign them against the chassis. Otherwise the plug-ins may not seat fully into the connector receptacles.*

*The screws holding these rails are located under the A13 Scope Logic board.*

2. To replace the A13 Scope Logic board, see the replacement procedure for that board in this section.

**NOTE**

*Make certain that the plastic pin guide on P91 is in place before reinstalling the circuit board. The interconnecting pins usually align vertically. However, they may not always align horizontally. Check the pins before reinstalling the board.*

3. Inspect the interconnecting pins of J95 and J96 on the A4 Regulator board. Check that the pin tips are straight and evenly spaced.
  - Reconnect the J57 connector to the board.
  - Reinstall the A4 Regulator board by inserting the J95 and J96 interconnecting pins into their connectors on the A1 Plug-In Interface board.
  - Reinstall the two Torx screws to the metal heatsink at the rear of the A4 Regulator board. There are two holes provided in the chassis, across from these screws, to insert a screwdriver.

**NOTE**

*If the power supply-mainframe ground (green-yellow) wire was removed, reconnect it before the power supply installation.*

4. Reinstall the Power Supply Module. See "Power Supply Module Removal" in this section.

**NOTE**

*The plastic (J71 cable) protector may interfere with the reinstallation of the power supply. Make certain that the cable protector is flat against the chassis. Guide the power supply across the cable protector.*

- Replace the bottom cover on the instrument. Turn the instrument right side up.



5. Check that the plastic pin guide on the A1 Plug-In Interface board connector is installed.

**NOTE**

*The interconnecting pins of J90 usually align in a vertical direction. But, they may not always align horizontally. Check the pins before reinstalling the A11 Main Processor board.*

- Move the flange of the cable protector out of the way. Move the J60 cable away from the chassis. Check that no wires will be pinched under the board.
  - Reinstall the A11 Main Processor board. Follow the replacement instructions given in the A11 Main Processor board removal procedure in this section.
6. Replace the top cover on the instrument.

# A4 Regulator Board

Remove and replace the A4 Regulator board as follows:

1. Remove the Power Supply Module. Refer to "Power Supply Module Removal" in this section.
2. If it is on its side, set the 11301 right side up.
3. Disconnect the J57 connector from the A4 Regulator board. See Figure 3-6. Note the index triangle locations for correct reconnection.

**NOTE**

*If the (optional) A15 Counter/Timer Reference board is installed, remove the J40 connector (See Fig. 3-6.)*

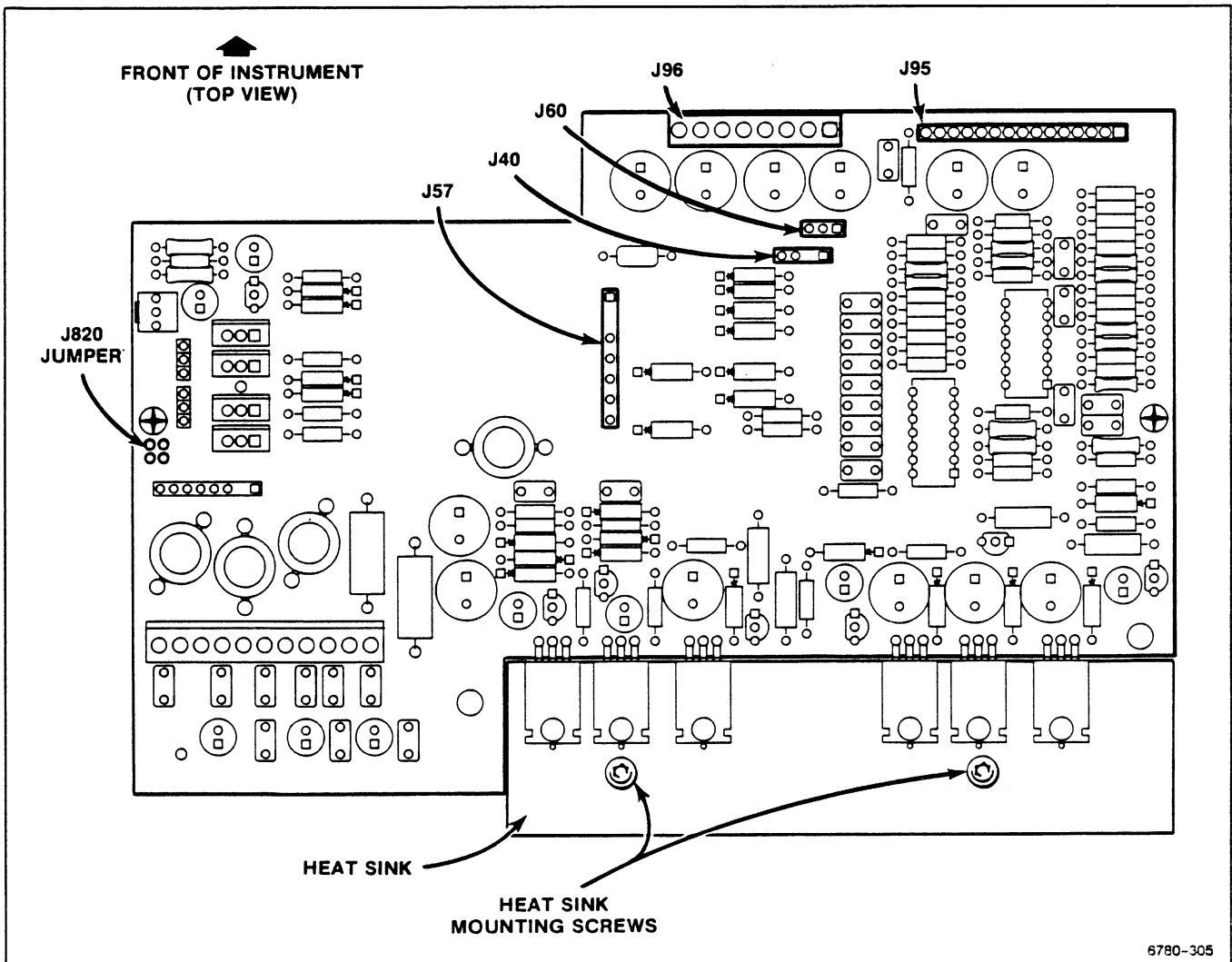

Figure 3-6. Connector and screw locations for the removal of the A4 Regulator board.

4. Remove the two Torx screws from the metal heatsink attached to the rear of the board. See Figure 3-6.

**NOTE**

*The A4 Regulator board is now unfastened from the chassis. However, it remains connected to the A1 Plug-In Interface board through interconnecting pins.*

5. Carefully disconnect pins J95 and J96 from the A1 Plug-In Interface board by pulling the A4 Regulator board towards the rear.
6. Remove the A4 Regulator board.

To replace the A4 Regulator board, follow the removal instructions in reverse order.

**CAUTION**

*Use care when reconnecting pins J95 and J96 to the A1 Plug-In Interface board. Should it become necessary, the A13 Scope Logic board may be removed to view these pins through the mainframe chassis. See the A13 Scope Logic board removal procedure in this section.*

**NOTE**

*Match the index triangle on the pin connectors with the corresponding triangle on the circuit board. Correct locations of the pin connectors are shown in the circuit board illustrations.*

## A7 Touch Panel Board

Remove the A7 Touch Panel board as follows:

1. Set the 11301 on its right side.
  - Remove the top cover.
2. Follow the removal (or replacement) procedure for the Front Panel Assembly in this section.
  - Set the instrument right side up.
3. Disconnect connectors J87 and J88 from the A10 Front Panel Interface board. See Figure 3-9.
  - Do not remove these cable connectors from the A7 Touch Panel board. The connectors are very difficult to reinstall on the board when it is in the instrument.
4. Remove the four retaining screws from the Crt Scale Cover (bezel) by using a diagonal method. See Figure 3-7. (Start with the #1 screw and follow the arrows to #4.)

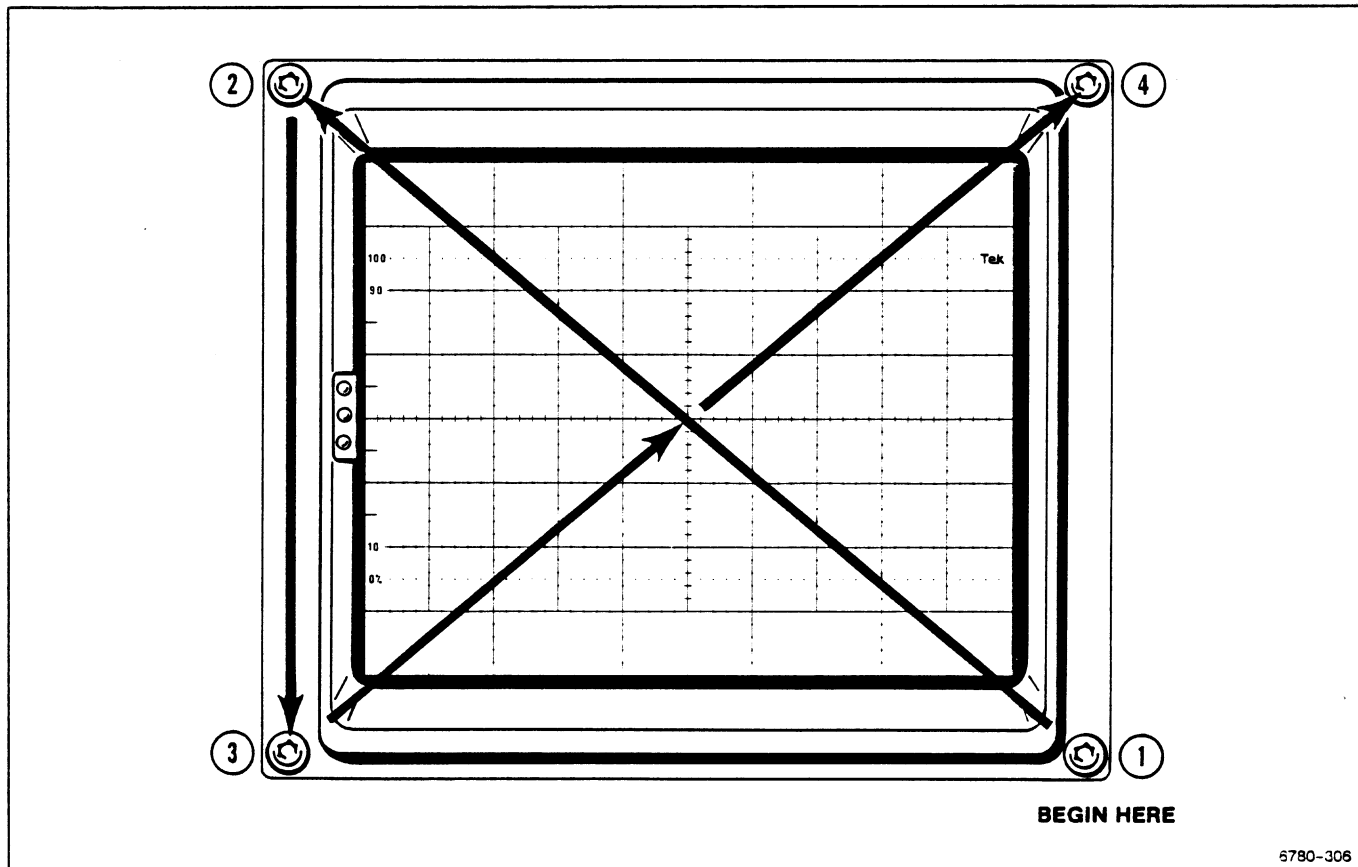

Figure 3-7. The diagonal method to remove (and to reinstall) the retaining screws on the 11301 crt scale cover.

**CAUTION**

*Do not remove or reinstall these screws by using a clockwise method. This will damage the corners of the crt faceplate.*

5. Remove the Crt Scale Cover.

**NOTE**

*If the Crt Scale Cover is replaced because of a defect, reinstall the EMI gaskets on each side.*

- The Crt Implosion Shield can be removed now. See “Implosion Shield Removal” in this section.

6. Remove the A7 Touch Panel board. (See Figure 3-8.)

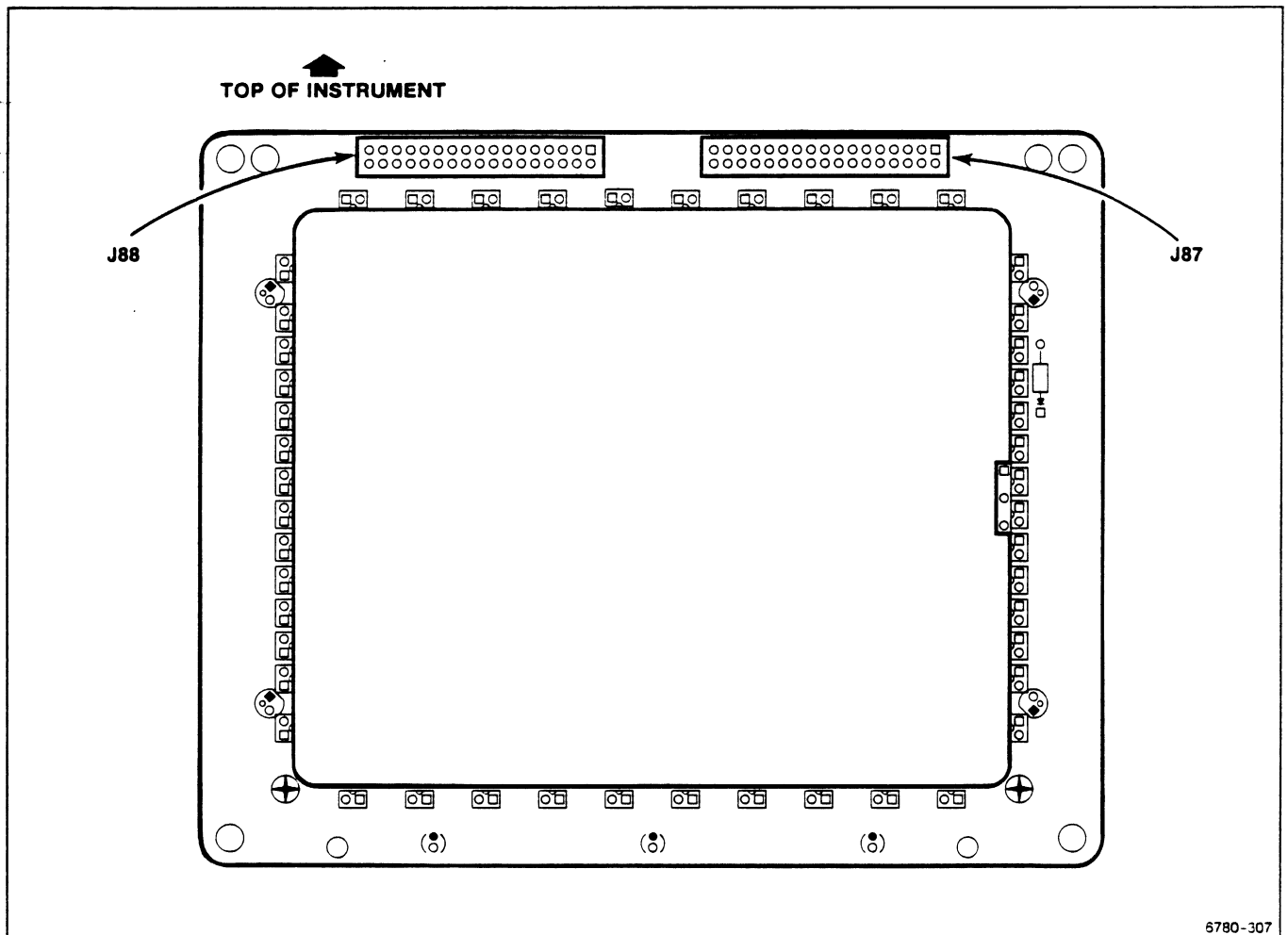

**Figure 3-8. Connector locations for the removal of the A7 Touch Panel board (inside view).**

- Withdraw cables J87 and J88 through the front casting.



*The Crt Implosion Shield may be loose and could fall off. Hold it against the A7 Touch Panel board.*

*The Implosion Shield can easily be scratched. Protect it while it is removed.*

7. The lens frame, the graticule light assembly, and the A7 Touch Panel board make up a single part. They are ordered as such (P/N 067-8835-XX).

**NOTE**

*The lens frame is press-fitted to the A7 Touch Panel board. The two can be separated, if desired.*

*To remove the lens frame, insert a thin, flat object, such as a metal rule, between the surfaces. Carefully pry the corners apart a little at a time.*

*To replace the lens frame, match the notched area on its inside edge with the camera power terminal on the A7 Touch Panel board. Press the corner surfaces together.*

Replace the A7 Touch Panel board by following the previous procedure in reverse order. Read the following NOTE and CAUTION first.

**NOTE**

*Check to see that the lens frame and implosion shield are mounted correctly. They should be against the crt scale cover (bezel) and crt faceplate respectively.*



*IMPORTANT: Reinstall the four retaining screws in the crt scale cover and tighten them diagonally. See Figure 3-7.*

*Begin with the FIRST screw and tighten it lightly until it stops turning. Next, go diagonally across the cover to the SECOND screw. Tighten it lightly until it stops turning. Then drop down to the THIRD screw and tighten it firmly. Go diagonally across the cover to the FOURTH screw. Tighten it firmly.*

*Next, go to the SECOND screw and tighten it firmly. Then return to the FIRST screw and tighten it firmly.*

Do not use a clockwise method to tighten these crt scale cover screws. That will damage the corners of the crt faceplate. An unnecessary removal and replacement of the crt could be the result.

## A10 Front Panel Interface Board

Remove the A10 Front Panel Interface board as follows:

1. Position the instrument right side up. Remove its top cover.
2. Remove connectors J59, J58, J88, J87, J57, J76, J72, J74, J75, J73, and J78. See Figure 3-9 for their locations.
3. A bracket is attached to the right front of the A10 Front Panel Interface board for the instrument's calibrator connections. Remove the 1/4-inch nut from this bracket. It is located behind the upper right front corner of this instrument.
4. Remove the four board-retaining screws.
5. Remove the A10 Front Panel Interface board.

To replace the A10 Front Panel Interface board, follow the previous procedure in reverse order.

### NOTE

*When the circuit board is reinstalled and its retaining screws are reattached, do not immediately tighten the screws. First, reinstall and tighten the nut to the calibrator bracket. Then tighten all the board-retaining screws.*

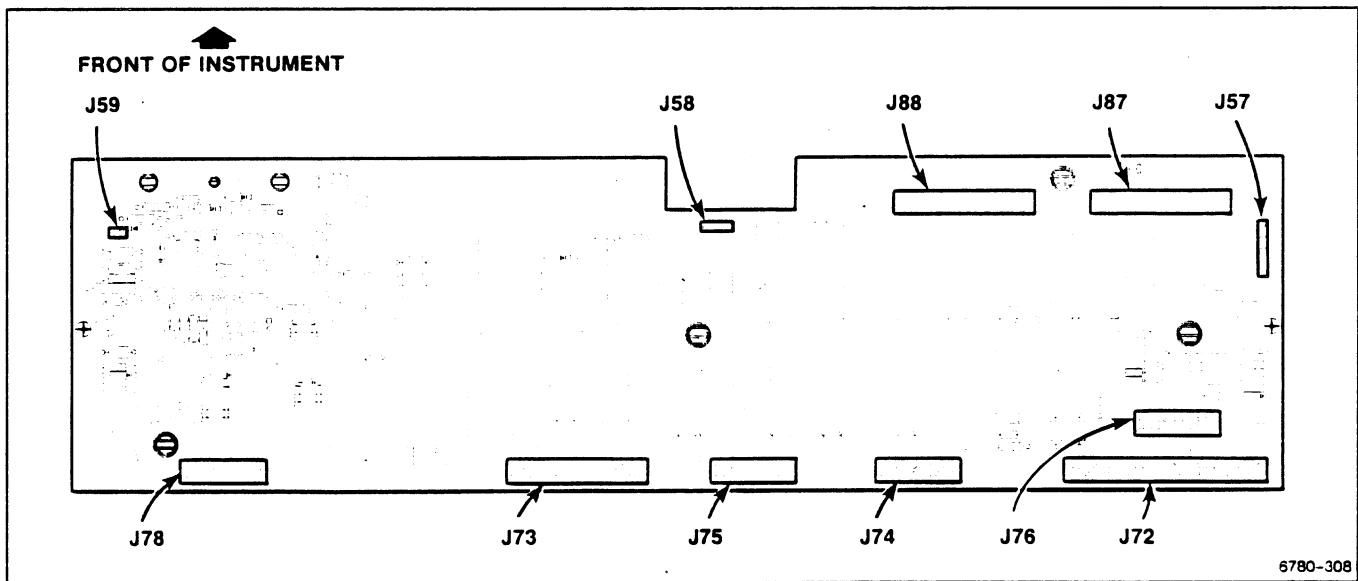

Figure 3-9. Connector locations for removal of the A10 Front Panel Interface board.



## A11 Main Processor Board

Remove the A11 Main Processor board as follows:

1. Set the 11301 right side up. Remove the top cover.
2. Disconnect connectors J78, J66, J72, J56, J24, J25, J41, J42, J60, and J71. See Figure 3-10.

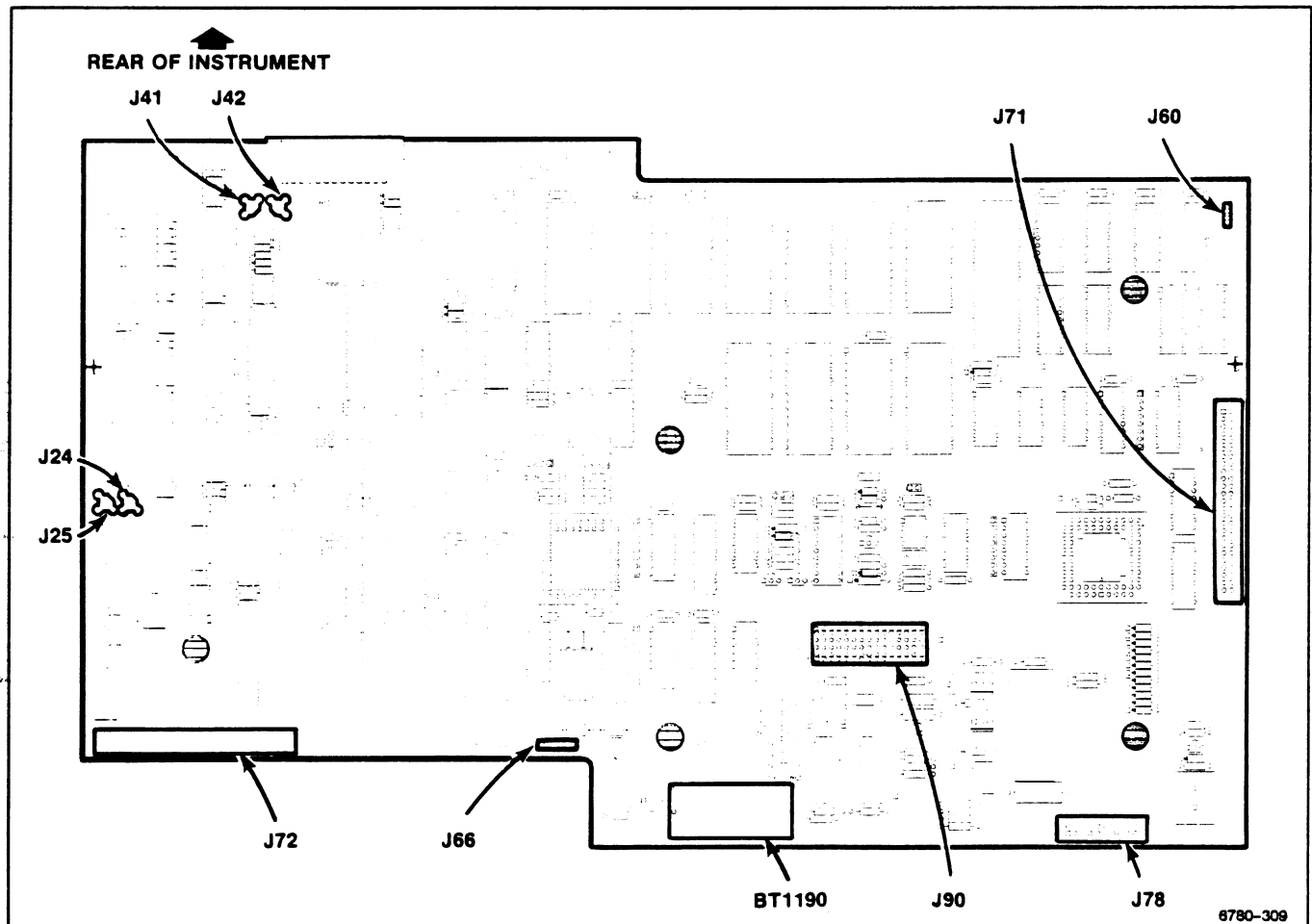

**Figure 3-10. Connector locations for removal of the A11 Main Processor board.**

3. Remove the hex mounting posts from the connectors on the rear panel as follows:
  - For the RS-232-C posts, use a 3/16-inch nutdriver.
  - For the GPIB posts, use a 1/4-inch nutdriver.
4. Move the plastic (cable protector) flange off the right side edge of the frame.
5. Remove the five board-retaining Torx screws.

6. Gently remove the A11 Main Processor board by lifting it from the chassis.

**CAUTION**

*The J90 interconnecting pins (of the A1 Plug-In Interface board) securely hold the A11 Main Processor board. The A11 Main Processor board should be lifted cautiously to prevent damage to either the connector or the circuit board.*

*A plastic pin guide covers the pins of the A1 Plug-In Interface board connector underneath the A11 Main Processor board. This guide may come off when the A11 Main Processor board is removed. Replace the guide if it does come off.*

**WARNING**

*A lithium battery (BT1190) is mounted on the A11 Main Processor board. This battery requires special handling for disposal. Refer to "Lithium Battery Disposal and First Aid" in this section.*

To replace the A11 Main Processor board, follow the previous procedure in reverse order. Additional instructions follow:

1. Move the J60 connector cable away from the board's position. Be certain that all wires are out of the way. Check that the plastic flange is moved off the side. See that the pin guide is on the connector of the A1 Plug-In Interface board.
2. Set the board into the 11301 so that the rear panel connectors are installed first. Next, align the pin guides with the holes in the board, at either end of the J90 connector. Press down on the board to connect the pins.
  - Check that all pins entered the J90 connector, and are about the same height.
3. Loosely reinstall the five board-retaining Torx screws.
  - Reinstall and tighten the hex posts on the rear panel connectors.

**NOTE**

*The RS-232-C hex posts have lockwashers which can be used to identify them.*

- Tighten the screws.

4. Reconnect the ten connectors. See Figure 3-10. Dress their cables.

**NOTE**

*The J41 and J42 Peltola cables are unmarked. To reconnect them, put the "outside" (Ready) Peltola into the "outside" J41 socket. The "inside" (Reset) Peltola plugs into the "inside" J42 socket.*

*The J60 connector cable is extra long. Dress it along and underneath the All Main Processor board and under the J71 connector.*

5. Move the plastic (cable protector) flange towards the inside of the 11301.
6. Reinstall the top cover.

# A12 Vertical Amp Board

Remove the A12 Vertical Amp board as follows:

1. Position the instrument on its right side. Remove its top and bottom covers.



*Do not lift the trim covers to remove them, they will break. There is a clip on the back of the cover which slides over the end of the side frame section.*

*To remove the trim cover, move each cover towards the end of the instrument where it is located. (The front cover moves towards the front and the rear cover moves towards the rear.) Moving the cover about 1/8 of an inch will release the clip. Then the cover can be lifted from the instrument. (See Fig. 3-11.)*

2. Remove the Torx screws from the (left side) front and rear decorative trim covers.
3. Remove the Torx screw from the center of the left side frame section. Remove the other two screws from its ends. Remove the frame section.

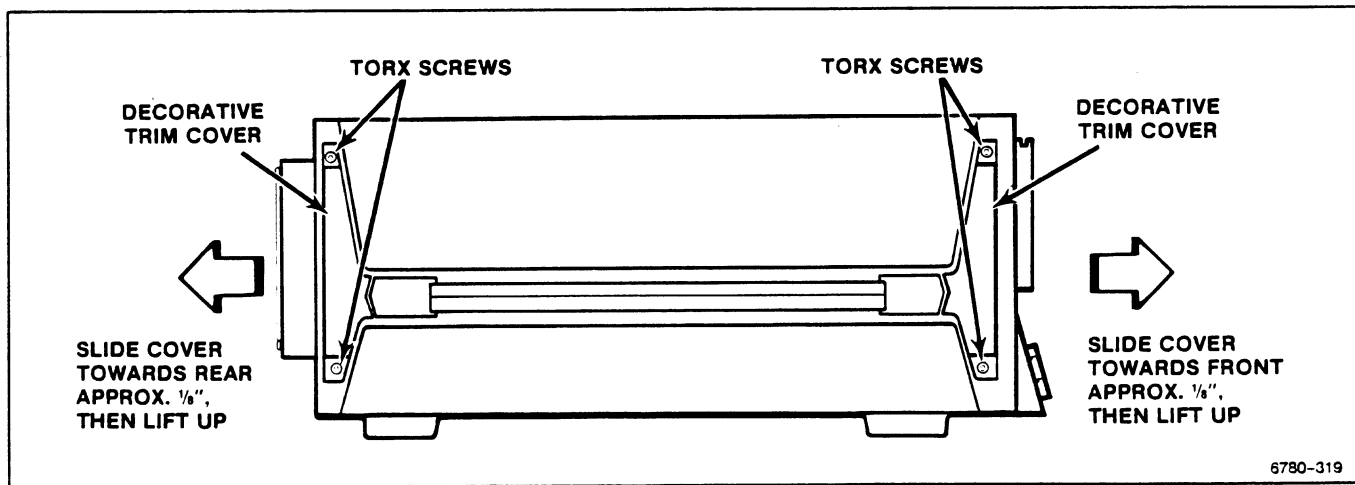
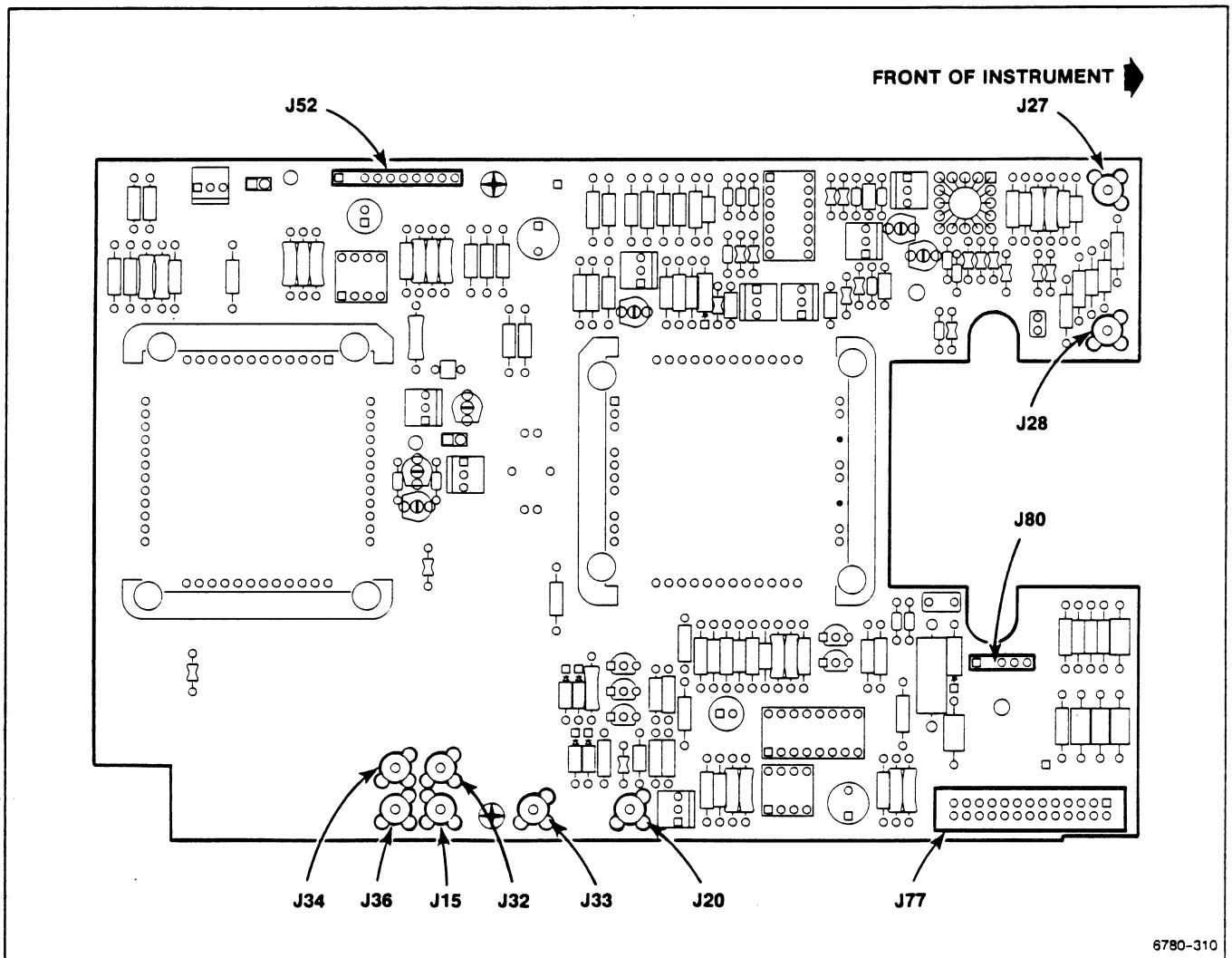

**Figure 3-11. Removal of left side decorative trim covers.**

4. Disconnect all connectors from the board. See Figure 3-12.
  - Remove the two crt deflection leads from the (rear) neck pinwires.

**NOTE**

*Do not remove or disturb the two crt leads from the front neck pin wires.*



**Figure 3-12. Connector locations for removal of the A12 Vertical Amp board.**

5. Remove the two board-retaining Torx screws.
6. Remove the A12 Vertical Amp board. Lift the front end of the board outward and slide the rear part past the chassis frame.

To replace the A12 Vertical Amp board, proceed as follows:

1. Reinstall the A12 Vertical Amp board. Insert its rear edge into the circuit board guide mounted on the rear casting. Lower the board into place over its spacer posts. Reinstall and tighten the board-retaining screws.
2. Reconnect all wire connectors. Reconnect the crt deflection leads to the rear neck pin wires.

**NOTE**

*Use care when reconnecting the deflection leads. Do not bend their respective crt neck pins.*

3. Reinstall the side frame section. Reinstall its screws and tighten them.
4. Reinstall the decorative trim covers to the front and rear of the side frame section. Slide their retaining clips (on the inside of each cover) into place. Reinstall the cover Torx screws and tighten them.
5. Replace the top and bottom covers on the instrument. Turn the instrument right side up.

## A13 Scope Logic Board

Remove the A13 Scope Logic board as follows:

1. Position the 11301 on its right side. Remove its bottom cover.
2. Remove the screws from the rear panel plate. Allow the plate to hang from its wires. Protect the surfaces underneath the plate from scratches.
3. Disconnect all the connectors from the A13 Scope Logic board. See Figure 3-13.

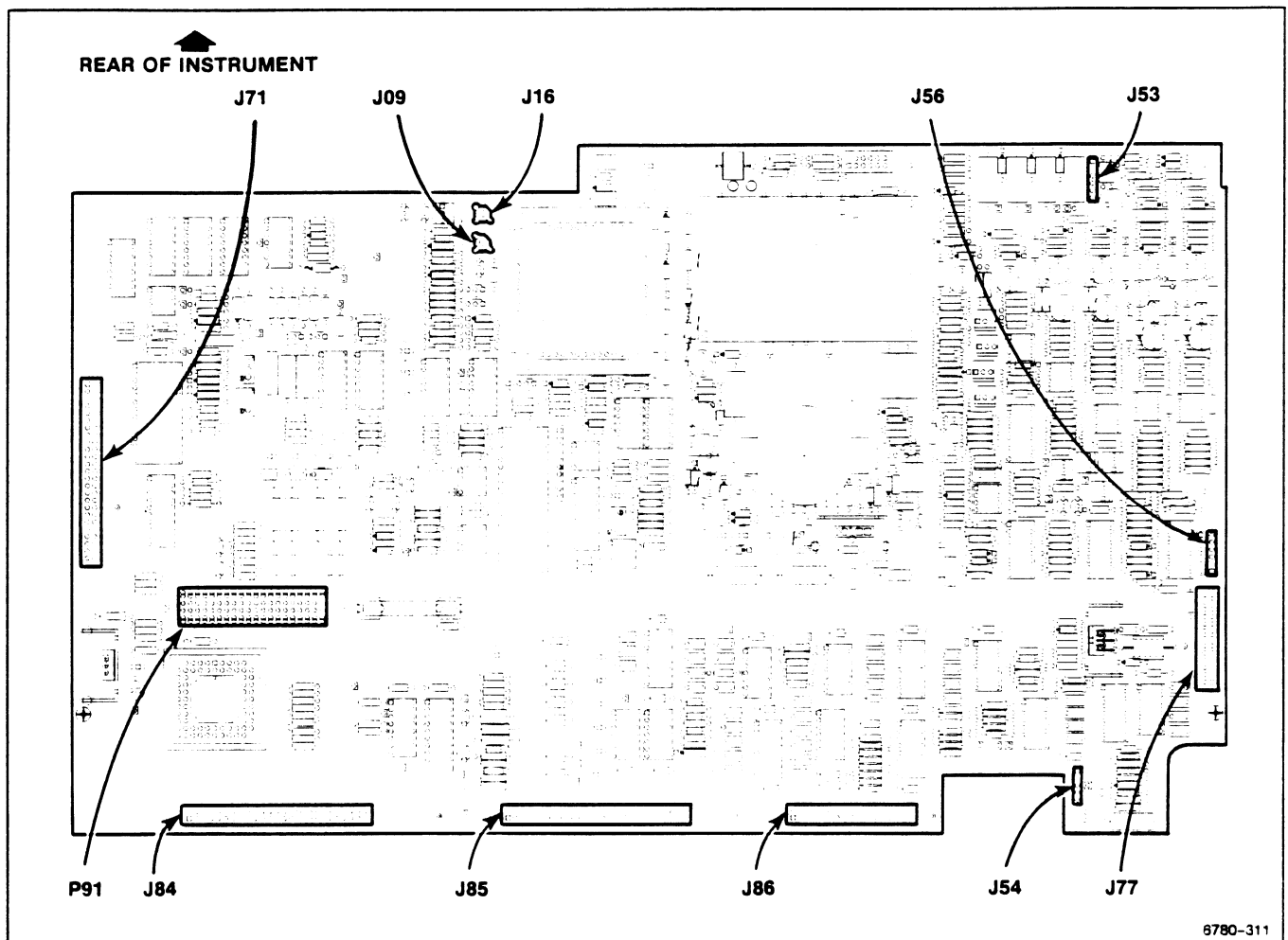

Figure 3-13. Connector locations for removal of the A13 Scope Logic board.

4. Pull the anode lead from its keyhole recess under the crt socket. See Figure 3-4.

**WARNING**

*The crt anode voltage is 20 kV. The crt may retain a dangerous electrical charge. The anode lead must be fully discharged upon removal. Ground the anode lead to the chassis. Wait approximately ten minutes and again firmly ground this lead to the chassis. Remove the crt. An hour after the anode lead was first discharged, ground it once more by touching it to the black conductive coating on the crt.*

*If 24 hours elapse between the removal and replacement of the crt, ground the anode by touching it to the black conductive coating on the crt.*

- Remove the anode lead from its holder. Discharge it to the chassis by following the preceding instructions.
5. Remove the crt base-pin socket from the crt. Remove its three cables held fast by a cable retainer. This retainer is located behind the middle grommet inside the rear panel plate.
    - Turn the 11301 on its top, with the bottom side up.
  6. Remove the Torx screws from the metal, high voltage shield. Remove the shield from the A13 Scope Logic board.
    - Remove the seven board-retaining Torx screws and the four 1/4-inch spacer posts from around the multiplier.
  7. Push the plastic (cable protector) flange off the edge of the chassis. It is located over the side edge underneath connector J71. If left in place, the flange might catch the side of the circuit board.

**CAUTION**

*The interconnecting pins (from the A1 Plug-In Interface board) firmly hold the A13 Scope Logic board's P91 connector. Therefore, the board should be lifted cautiously to prevent damage to either the connector or the circuit board.*

8. Remove the A13 Scope Logic board.

**NOTE**

*A plastic pin guide covers the A1 Plug-In Interface board connector. If this guide comes off when the A13 Scope Logic board is removed, reinstall it.*



To replace the A13 Scope Logic board, proceed as follows:

**NOTE**

*The 11301 should be turned on its top with its bottom side up.*

1. Hold the board over its approximate location.
  - Thread the anode holder cable and the base-pin socket cables through their grommets into the rear panel.
  - Check that no wires will be pinched under the board.
  - Align the pin guides with the board's pin holes at either end of connector P91.

**NOTE**

*The interconnecting pins from the A1 Plug-In Interface board usually align vertically. However, they might not always align horizontally. Check the pins before reinstalling the board.*

- Press down on the board to connect the pins. Check that all pins re-enter the connector and are about the same height.
  - Check that cable J71 remains flat against its plastic cable protector.
2. Position the 11301 on its right side.



*The crt anode lead may need to be grounded before replacing the crt. If more than 24 hours have elapsed since the crt was removed, ground the lead to the black conductive coating on the crt.*

- Reconnect the anode lead into its holder. Slide the anode and cable into their keyhole recess of the crt support beneath the crt socket. See Figure 3-4. Dress the other end of the anode cable into the uppermost grommet.
3. Reinstall the crt base-pin socket. Replace the three crt socket cables into their cable retainer.
    - Reconnect connector J53 to the A13 Scope Logic board. Route the cable into the center grommet. Dress the cable underneath the socket and anode cables along the edge of the board.
    - Check that all Peltola connectors are inserted into their BNC sockets on the rear panel plate.
    - Place all cables into their grommets. Check that there won't be any wires caught behind the plate.

4. Reinstall the rear panel plate. Reinstall the six Torx screws to the plate. Tighten the screws.
5. Reinstall the four 1/4-inch spacer posts around the multiplier on the A13 Scope Logic board. Tighten the posts.
  - Reinstall the seven board-retaining Torx screws and tighten them.
  - Push the flange of the plastic cable protector into place underneath the J71 connector.
6. Reconnect all connectors to the board. See Figure 3-13.

**NOTE**

*The J23 and J26 Peltola cables (to the A14 Time Base board) are dressed alongside the J84 and J85 connectors on the front edge of the board. These cables lie near the adjoining edges of the circuit boards. Dress them in between the four holders of the J84 and J85 connectors.*

*If the (optional) A15 Counter/Timer Reference board is not installed, the J26 Peltola cable will be removed.*

7. Replace the metal high voltage shield over the (multiplier) spacer posts.



*Do not over tighten the spacer posts, they may break off.*

- Reinstall the four Torx screws into the spacer posts and tighten.
8. Replace the bottom cover. Set the 11301 right side up.

# A14 Time Base Board

Remove the A14 Time Base board as follows:

1. Set the 11301 on its right side. Remove the bottom cover.
2. Remove the 1/4-inch nut that holds the EXTERNAL TRIGGER & COUNTER INPUTS bracket to the front casting. This nut is located behind the lower right front corner.
3. Disconnect the two leads from the crt horizontal neck pins. These are located on the upper rear edge of the board.
4. Disconnect all connectors. See Figure 3-14.
5. Remove the seven board-retaining Torx screws.
6. Remove the A14 Time Base board.

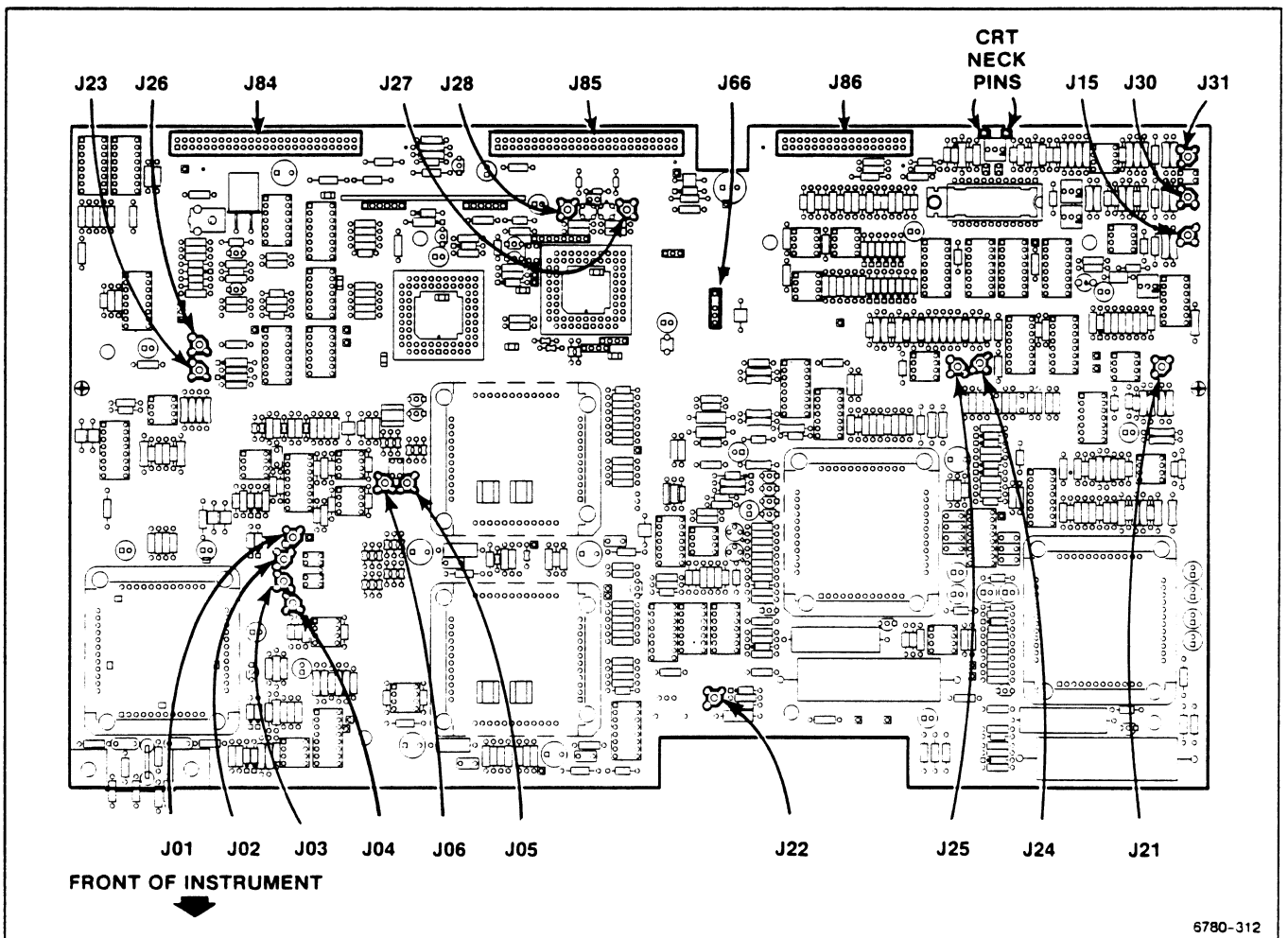

Figure 3-14. Connector locations for removal of the A14 Time Base board.

To replace the A14 Time Base board, proceed as follows:

1. Check that all wires are out of the way.
2. Replace the A14 Time Base board.
  - Align the BNC connectors on the EXTERNAL TRIGGER AND COUNTER INPUTS bracket with their respective holes in the front casting.
3. Loosely reinstall the seven board-retaining Torx screws.
  - Reinstall the 1/4-inch nut to the bracket and tighten it.
  - Tighten the Torx screws.
4. Reconnect all connectors and the crt neck pin leads.

**NOTE**

*The J23 and J26 Peltola cables are dressed alongside the J84 and J85 connectors on the rear edge of the board. These cables lie near the adjoining edges of the circuit boards. Dress them in between the four holders of the J84 and J85 connectors.*

*If the (Optional) A15 Counter/Timer Reference board is not installed, the J26 Peltola cable will be removed.*

5. Replace the bottom cover. Set the 11301 right side up.

## A15 Counter/Timer Reference Board

The A15 Counter/Timer Reference board is an 11301 instrument option (number 1T). If installed, it is mounted on the chassis inside the rear panel.

Remove the A15 Counter/Timer Reference board as follows:

1. Position the 11301 on its left side, as facing the rear.
2. Remove the six Torx screws from the rear panel plate. (See Figure 3-16.)
3. Ease the rear panel plate away from the rear casting. Allow the plate to remain suspended from its wire connections.
  - Protect the surfaces underneath the plate from scratches.
4. As viewed from the rear, the A15 Counter/Timer Reference board (see Fig. 3-15) is located to the left of the crt socket.

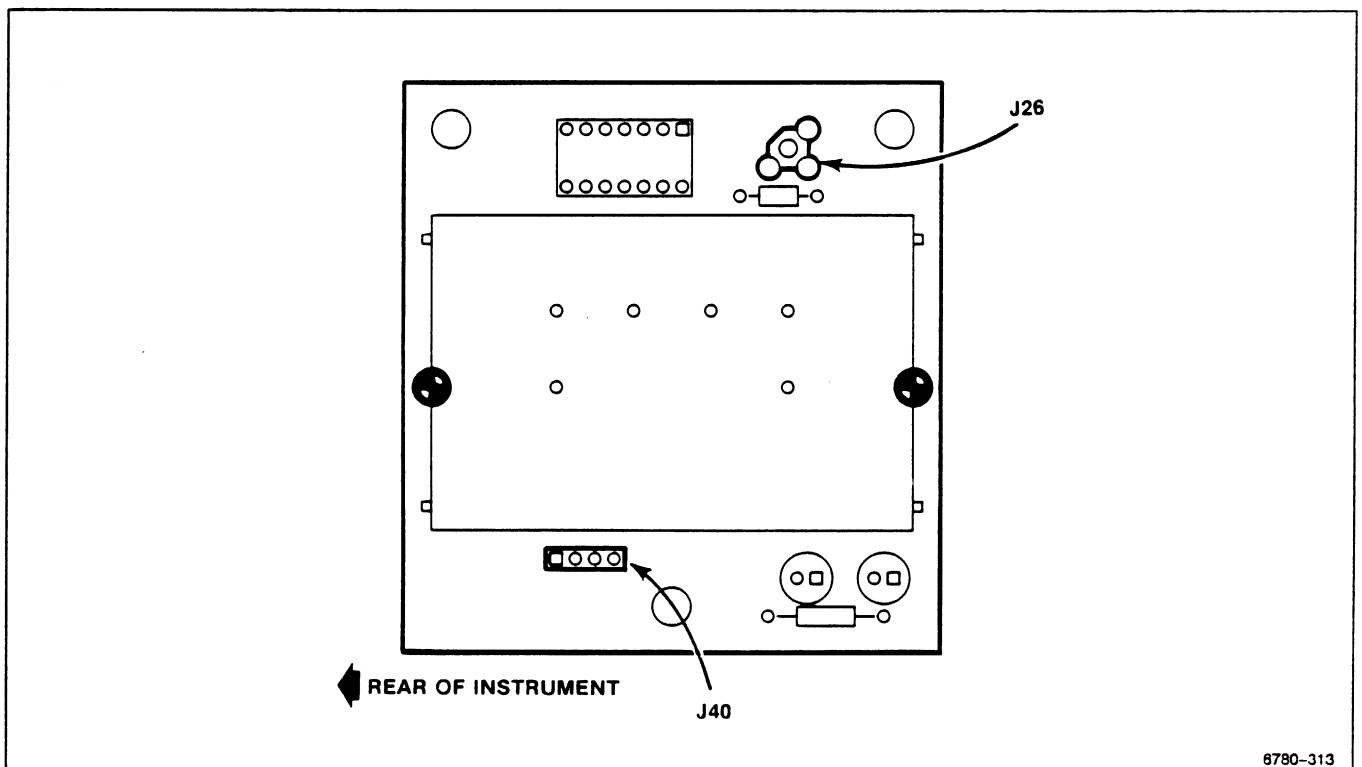

Figure 3-15. Connector locations for removal of the A15 Counter/Timer Reference board (option 1T).

5. Remove the two connectors from the board.
  - J26 originates on the A14 Time Base board.
  - J40 originates on the A4 Regulator board.

6. Unfasten the retainers from the three circuit board supports.
7. Remove the A15 Counter/Timer Reference board.

To replace the A15 Counter/Timer Reference board, follow the preceding steps in reverse order.

**NOTE**

*Be certain that all Peltola connectors are reinstalled into their BNC sockets before reinstalling the rear panel plate.*

## Rear Panel Plate Removal

Remove the rear panel plate as follows:

1. Remove the six Torx screws from the rear panel plate. See Figure 3-16.

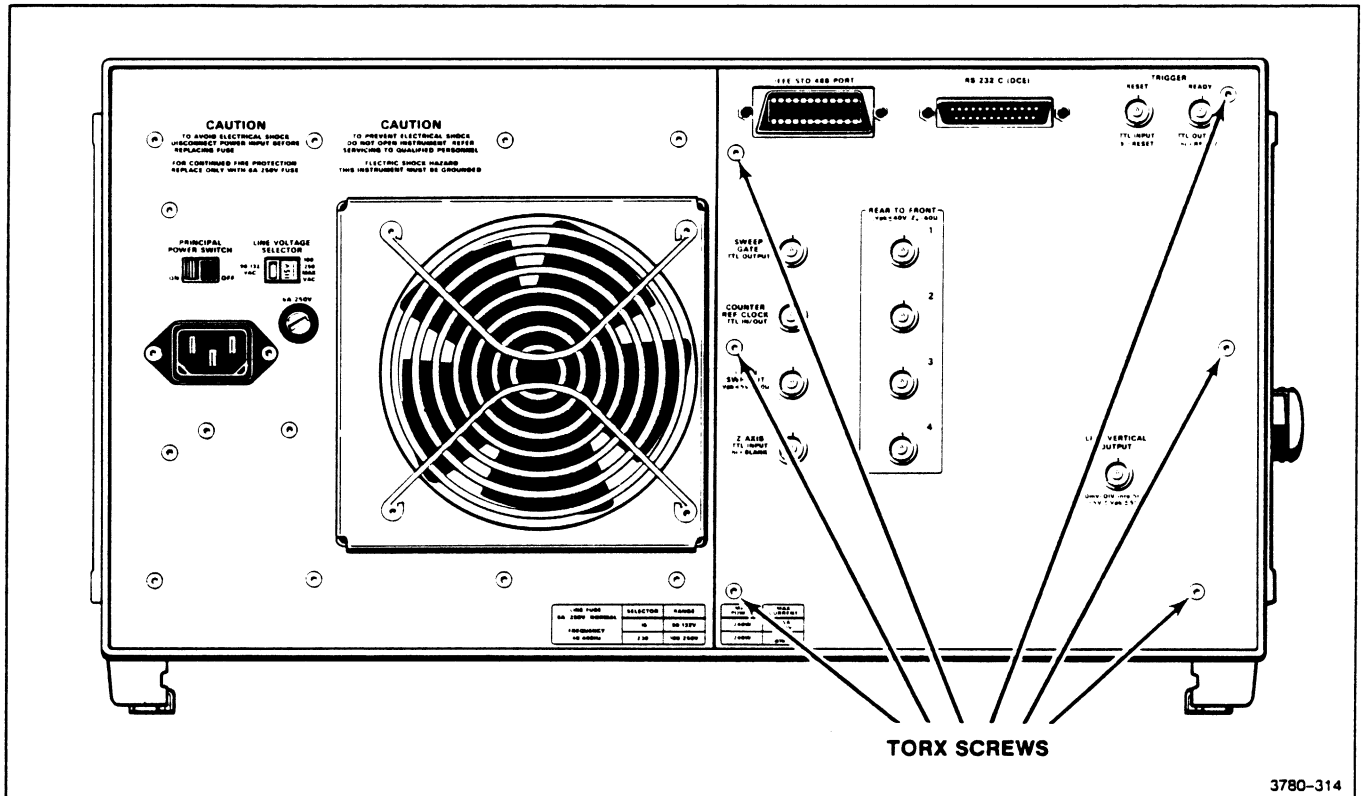

Figure 3-16. Location of rear panel plate mounting screws.

2. Place the 11301 on its right side, as facing the front.
3. Ease the rear panel plate away from the rear casting. Allow it to remain suspended from its wire connections.
  - Protect the surfaces underneath the plate from scratches.
4. Remove the 5/16-inch nut from the ground wire connection.
  - Remove the ground wire.

### NOTE

*Record the locations of the Peltola wires so that they can be correctly reconnected.*

5. Remove the Peltola connectors.

6. Remove the rear panel plate.

To replace the rear panel plate, follow the previous instructions in reverse order.

**NOTE**

*Be certain that all wires are out of the way before reinstalling the rear panel plate.*

*Check that all Peltola connectors are reinstalled into their BNC sockets.*



## R80 Crt Termination Network

Remove the R80 Crt Termination Network as follows:

1. Position the instrument on its right side. Remove its top and bottom covers.



*Do not lift the trim covers to remove them, they will break. There is a clip on the back of the cover which slides over the end of the side frame cover.*

*To remove the trim cover, move each towards the end of the instrument where it is located. (The front cover moves towards the front and rear cover moves towards the rear.) Moving the cover about 1/8-inch will release the clip. Then, the cover can be lifted from the instrument. (See Fig. 3-11.)*

2. Remove the Torx screws from the left side front and rear decorative trim covers.
3. Remove the Torx screw from the left side frame section. Remove the other two screws from its ends. Remove the frame section.
4. Remove the two crt leads from the front neck pin wires.
5. Remove the two Torx screws that hold the Crt Termination Network, R80, to the bracket mounted on the left side frame section.
6. Remove the Crt Termination Network.

To replace the R80 Crt Termination Network, follow the preceding steps in reverse order.



*Use care when reconnecting the front neck pin wires. Do not bend their respective crt neck pins.*

## FRU IC Replacement

### “Slam-Pack” Integrated Circuits

“Slam-Pack” ICs are located on the A11 Main Processor board and the A13 Scope Logic board.

Some of the IC covers have raised, ridged heatsinks. Others may have flat covers without heatsinks. The IC is oriented to its socket by a flat corner. The other corners are notched to fit the edges of the socket. The flat-edged corner of the IC aligns with a spring (small metal tab) at one corner of the socket.

To remove a Slam-Pack IC, proceed as follows:

1. While holding the cover in place, unfasten its holding clip by pushing it aside. It may help to push down slightly on the cover.
2. Remove the cover slowly to prevent the IC from falling out.

#### NOTE

*Observe the index of the IC before removing it.*

3. Remove the IC with tweezers.

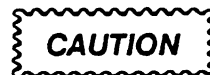

*Avoid touching the IC or the socket contacts with your fingers. Finger oils can lower reliability.*

Replace the Slam-Pack IC as follows:

1. Using tweezers put the flat edge of the replacement IC against its index spring.



*Check that the spring is not bent by the flat corner.*

2. Arrange the other corners with tweezers to fit evenly at the edges of the socket.
3. Push the end tabs of the cover into the holders at one end of the socket.
4. Push down on the cover. Hold it there while moving the holding clip over the tabs on the opposite end of the cover.

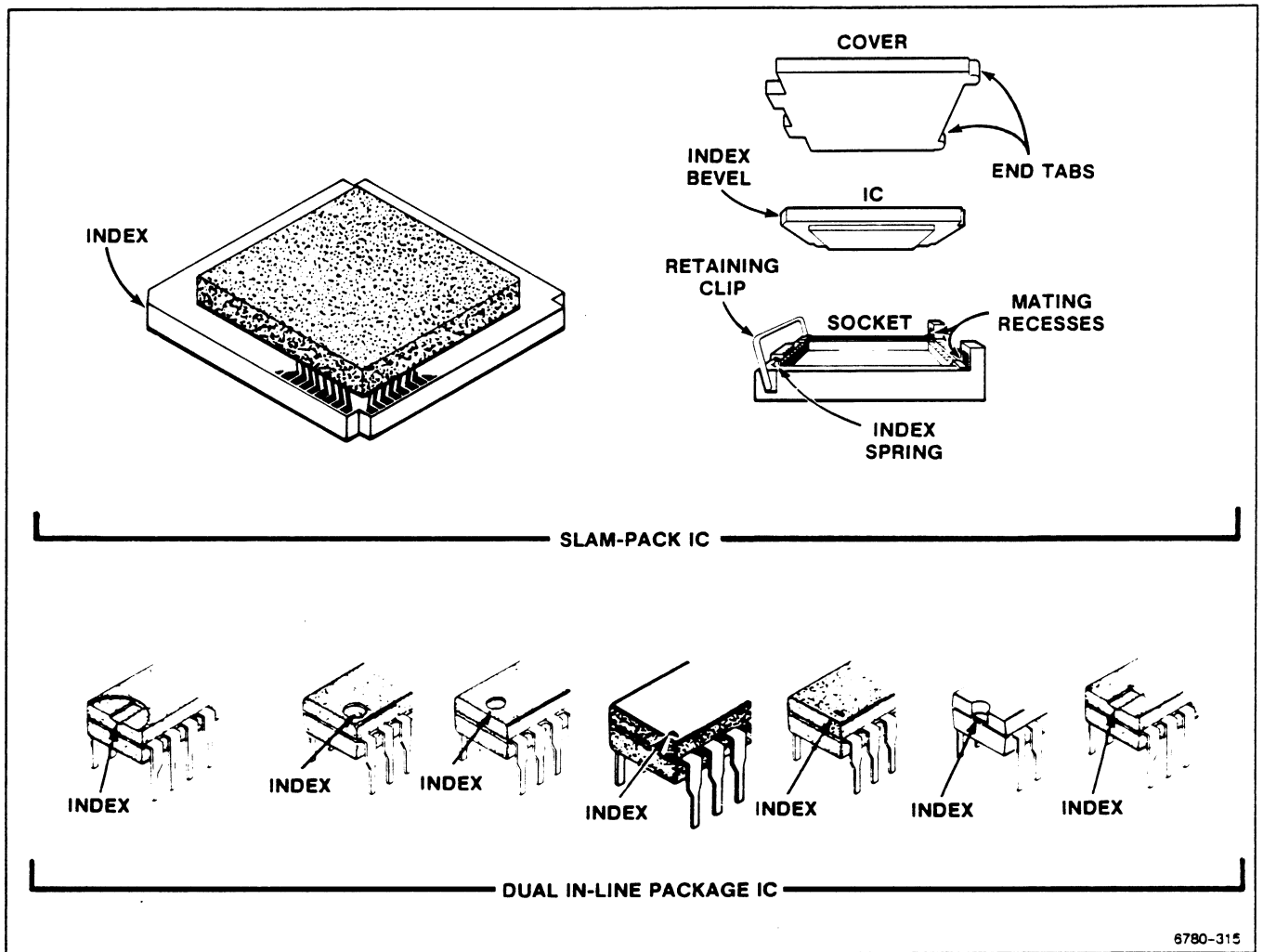

Figure 3-17. IC lead indexing diagram.

## Firmware Integrated Circuits (“Dual In-Line Package” ICs)

The firmware ICs are located on the A11 Main Processor board. See Figure 3-1 for the IC locations.

All the ICs are ordered by a single Tektronix Part Number. (Individual ICs cannot be ordered separately.) The total firmware kit number is 020-1577-XX.

### Preliminary Verification Procedure

1. Set the ON/STANDBY switch to ON.
2. Press the ENHANCED ACCURACY button and observe that the enhanced accuracy cycle is completed without failure. If failure does occur, do not proceed with this procedure until the instrument has been repaired.

### Firmware Upgrade Procedure



*The instrument is extremely vulnerable during firmware version changes. If this procedure is not followed precisely, the instrument will have to be completely recalibrated.*

*All settings previously saved during power down will be lost as a result of this procedure.*

To remove and replace the firmware ICs, proceed as follows:

### WARNING

*Dangerous shock hazards may be exposed when the instrument covers are removed. Before proceeding, ensure that the PRINCIPAL POWER SWITCH is in the OFF position. Then disconnect the instrument from the power source. Disassembly should only be attempted by qualified service personnel.*



*Observe all the special precautions mentioned under the heading “Static-Sensitive Device Classification” in this section.*

1. Make sure that the PRINCIPAL POWER SWITCH is set to OFF.

2. Install a 11000-series plug-in unit in the left plug-in compartment.
3. Remove the top cover from the 11301.
4. Set number 2 and number 4 dip switches on the A11 Main Processor board to their closed positions.
5. Replace U1000, U1100, U1200, U1230, U1300, U1330, U1400, and U1430 on the A11 Main Processor board with the new EPROMs. See Figure 3-1 for the location of these ICs.
6. Store EPROMs that were removed from the A11 Main Processor board in an antistatic carrier.



*Be certain that pin 1 is positioned correctly when replacing ICs.*

#### NOTE

*Use IC insertion-extraction pliers to remove and replace the ICs. See Figure 3-18 for an illustration of these pliers.*

*Do not use the label on the IC for an index because it may be applied with one of two orientations. See Figure 3-17 for the correct indexing information.*

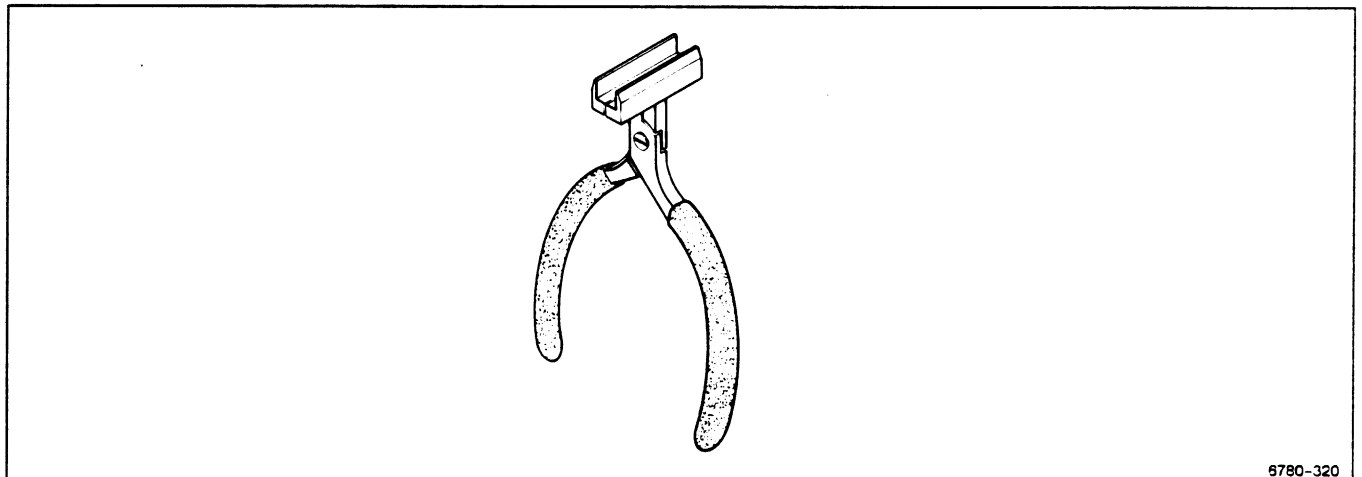

**Figure 3-18. IC insertion-extraction pliers.**

7. Turn the **PRINCIPAL POWER SWITCH** to **ON**. Initially the **PROCESSOR diagnostic (BBr Quick)** test will fail; this will only occur during the first power-up sequence following the firmware installation.
8. Press the **Disp Adj** button and wait for the screen message **Diagnostics Are Complete**.
9. Adjust **Focus, Astigmatism, and Trace Rot**.

10. Press the ENHANCED ACCURACY button and observe that the Enhanced Accuracy cycle is completed without a failure. If failure does occur, a complete instrument recalibration is necessary.
11. Turn the PRINCIPAL POWER SWITCH to OFF.
12. Set number 2 and number 4 dip switches to the open position.
13. Replace the 11301 top cover.

## Cables and Connectors

A cabling diagram (see Fig. 3-19) is provided to show the interconnecting cables between the various circuit boards, modules, and assemblies. Use this diagram for a reference when you are removing and/or replacing cables on these units.

### Restoring Factory Calibration

To restore factory calibration if it has been lost, proceed as follows:

1. Turn the ON/STANDBY switch to STANDBY.
2. Remove the lithium battery (BT1190) from its holder on the A11 Main Processor board. Refer to “Lithium Battery Handling, Disposal, and First Aid” in this section for battery removal instructions.
3. Short circuit the terminals of the battery holder.
4. Remove the short circuit.
5. Reinstall the battery.
6. Turn the ON/STANDBY switch to ON.
7. Return to Step 10 of the Firmware Upgrade Procedure.

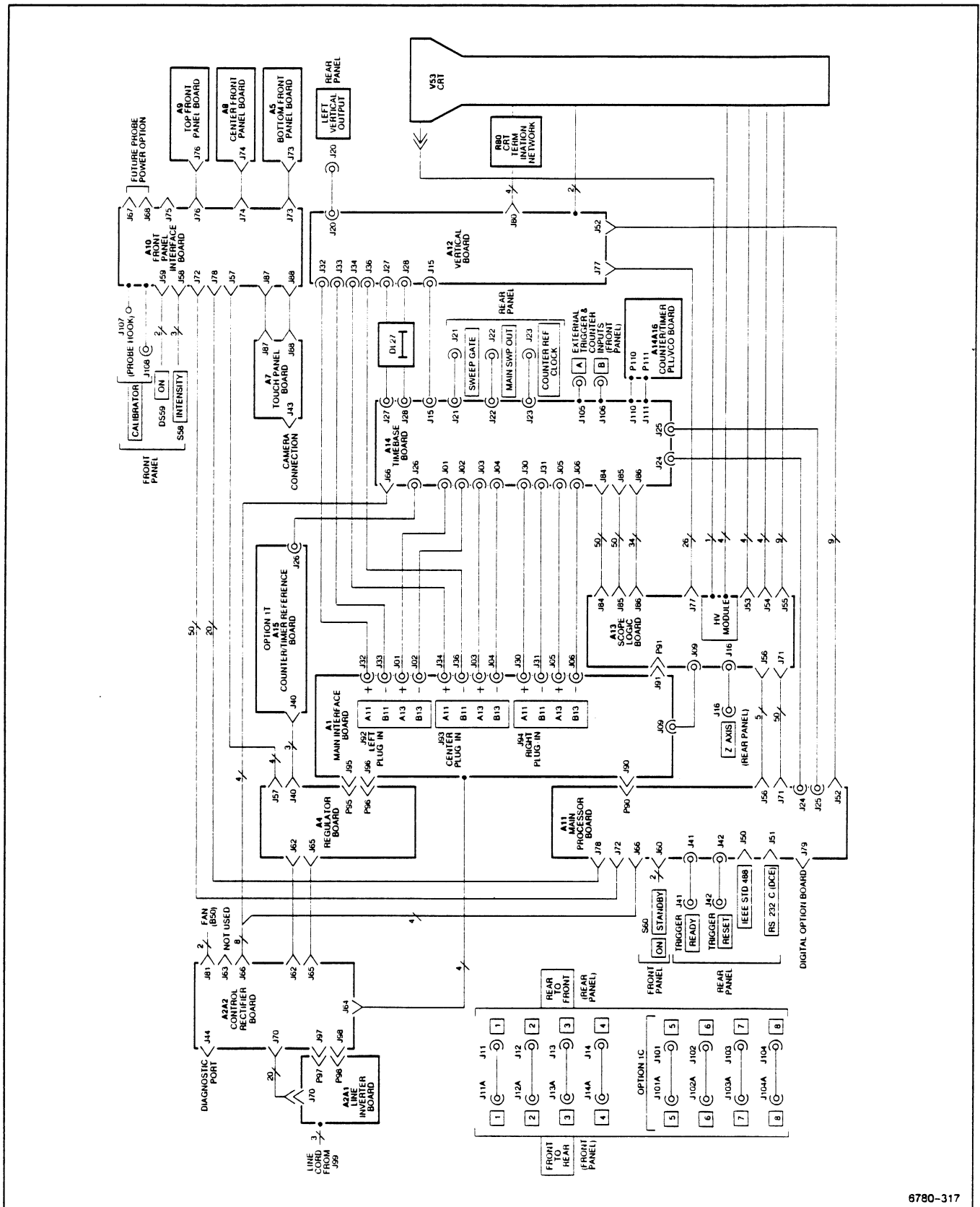

Figure 3-19. 11301 Cabling Diagram.

## Interconnecting Pins

Two methods of interconnection are used to electrically connect circuit boards with other boards and components. When the interconnection is made with a coaxial cable, a special end-lead connector plugs into a socket on the board. Other interconnections are made with a pin soldered into the board.

Two types of connectors are used for these interconnecting pins. If the connector is mounted on a plug-on board, a special socket is soldered into the board. If the connector is on the end of a lead, an end-lead pin connector is used which mates with the interconnecting pin. The following information provides the removal and replacement procedure for the various types of interconnecting methods.

## Coaxial-type End Lead Connectors (Peltolas)

Color coding of wires may be helpful to connect a Peltola connector to its socket on a circuit board. The wire insulation's color, or its colored stripe, is the same as the color represented by the last digit of the JXX component number. (EXAMPLE: a green wire would connect to a J05 socket number.) Some Peltolas may have small bands with the number written on them, while others may have no markings at all.

## Multi-Pin Connectors

The pin connectors used to connect the wires to the interconnecting pins are clamped to the ends of the associated leads.

Some of the pin connectors are grouped together and mounted in a plastic holder. The overall result is that these connectors are installed and removed as a multi-pin connector. If the individual end-lead pin connectors are removed from the plastic holder, note the order of the individual wires for correct replacement into the holder.

To remove or replace damaged multi-pin connectors, remove the old pin connector from the end of the lead and clamp the replacement connector to the lead.

Pin 1 on multi-pin connectors is designated with a triangle (or arrowhead). A triangle, dot, or square printed on circuit boards denotes pin 1. When a connection is made to a circuit board, the orientation of the triangle on the multi-pin holder is determined by the index (triangle, dot, or square) printed on the circuit board. See Figure 3-20. Most circuit-board mounted connectors have a triangle index mark.

### NOTE

*Some multi-pin connectors are keyed by a gap between the pin 1 and 3 positions in the holder. (A small plastic plug covers the pin 2 position on the end of the holder.) There is a corresponding gap between pins 1 and 3 on the circuit board.*

*Align the plug in the multi-pin holder with the gap between the circuit board pins. The connector is then ready to be installed*



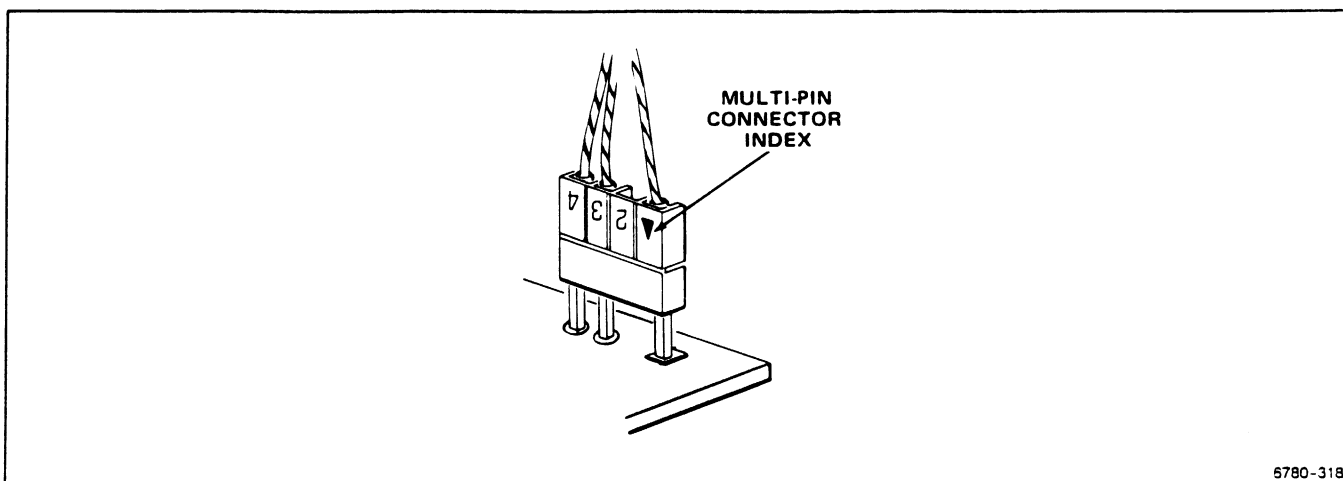

**Figure 3-20. Orientation of multi-pin connectors.**

Many of the larger gray-colored multi-pin ribbon connectors have a red line along one side of their attached wire cables. This red line indicates the location of pins 1 and 2 and also the location of the triangle index mark.

Some of the gray-colored ribbon cables may be stamped with the number of their connectors.

To remove these ribbon connectors, grasp the white pull-tab (fastened into the connector, if there) and pull it loose from the holder. If there isn't a white pull-tab present in the connector, grasp the ends of the connector instead. Pull it straight out from the connector socket.

## Implosion Shield Removal

Remove the Implosion Shield as follows:

1. Follow steps 1 through 5 of the A7 Touch Panel board removal procedure, in this section.
2. Tilt the A7 Touch Panel board outward at its bottom. Do not remove the J87 or J88 cables through the front casting.
3. Remove the Implosion Shield from the bottom. No further disassembly of the A7 Touch Panel board is required.



*Use care when handling the Implosion Shield. It can easily be scratched or marred. Protect the surfaces of the shield while it is out of the instrument.*

To replace the Implosion Shield, proceed as follows:

1. Reinstall the Implosion Shield to the A7 Touch Panel board. The Implosion Shield can be reinstalled either side out. But, it must align with the A7 Touch Panel board.
2. Follow the procedure to replace the A7 Touch Panel board, in this section. After reading the replacement instructions, begin at step 5.
  - Be certain to heed the CAUTION regarding the instructions to reinstall the crt scale cover screws. It is located at the end of the A7 Touch Panel board replacement procedure.

## FRU Fuses

There are several FRU fuses in the 11301. Replace each fuse with another of the proper type and rating as described in the Replaceable Parts list. For more information on FRU fuses refer to Fuse Troubleshooting later in this section.

## Line Fuse

The line fuse (F99) is mounted in a fuseholder that is accessible on the rear panel of the Power Supply Module.

### NOTE

*Line fuse F99 is used for both 115 V and 230 V operation. It is not necessary to change the fuse when switching the LINE VOLTAGE SELECTOR switch between 115 V and 230 V.*

## Circuit Board Fuse

A13F560 (Tektronix Part 159-0021-00) is a 2A cartridge fuse mounted in fuse clips on the A13 Scope Logic board.

If this fuse is faulty, remove it from the clips and replace it with a fuse of the proper type and rating.

## Checks After FRU Replacement

After certain FRUs are replaced, they must be checked or adjusted as described here.

### Crt



*Do not turn the instrument power on after replacing the crt until you have read the following information.*

After the crt has been replaced according to the instructions in this section, the following adjustments and checks should be made.

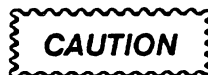

*A bright dot may appear on the screen of the new crt after it has been installed. To avoid possible damage to the crt, adjust the grid bias (R952) to extinguish the bright dot when the instrument is turned on. Refer to "Display Quality" in Section 2 for the location of this adjustment. The final adjustment of R952 must be performed when the instrument has fully warmed up. For now, adjust R952 so that no trace or readout is visible when the character and trace intensities are set to their minimum values.*

1. Adjust the front-panel Focus and Astigmatism controls for the best display.
  - Adjust R1600 on the A13 Scope Logic board (refer to "Part 8 – Display Quality" in Section 2 of this manual for the adjustment location) for the clearest display.
  - Readjust the front-panel Focus and Astigmatism controls for the best display.
  - Repeat the previous adjustments until the display is usable.



*Follow the instructions in "Mainframe Preparation" in Section 2 before performing the following adjustments.*

2. Perform the following adjustments as described in Section 2:
  - Part 12 – Vertical Center
  - Part 13 – Magnified Registration
  - Part 15 – Plug-In Interface Gains
  - Part 19 – Beam Registration (Do only the **grat\_prep** adjustment using the PC.)
  - Run the **autocal\_vert** test from the PC menu. When this test has completed, the readout display should be properly aligned to the crt graticule.
  
3. Verify crt performance by completing the following checks and adjustments (as described in Section 2) in the order listed. To verify the performance of the entire instrument, it will be necessary to perform the complete Checks/Adjustment procedure given in Section 2.
  - Part 2 – Extended Diagnostics
  - Part 7 – Front Panel Display Adjustments
  - Part 8 – Display Quality
  - Part 10 – Spot Shift
  - Part 12 – Vertical Center
  - Part 13 – Magnified Registration
  - Part 15 – Plug-in Interface Gains (all subsections)
  - Part 16 – Vertical Center (Second Pass)
  - Part 17 – Sweep Slew Rate Selfcal
  - Part 18 – Sweep Gains
  - Part 19 – Beam Registration
  - Enhanced Accuracy
  - Part 20 – Cursor to Graticule Match
  - Part 23 – Intensity Settings
  - Part 24 – Install Instrument Covers
  - Part 25 – Sweep Timing Accuracy
  - Part 28 – Vertical High Frequency Response
  - Part 44 – Store Cal Constants
  - Part 45 – Reset DIP Switches

## Crt Termination Network

After the Crt Termination Network has been replaced, perform the following checks and adjustments:

### NOTE

*To verify the performance of the entire instrument, perform the following checks and adjustments and then perform the entire Checks/Adjustments procedure described in Section 2.*

1. Follow the instructions in “Mainframe Preparation” in Section 2.
2. Perform the following checks and adjustments described in Section 2:
  - Part 12 – Vertical Center
  - Part 15 – Plug-in Interface Gains (Vertical Gain section only)
  - Part 28 – Vertical High Frequency Response

### NOTE

*When adjusting the vertical amplifier step response, optimize the following items before altering other amplifier adjustments: the lead dress of the wires from the Crt Termination Network to the crt, and the setting of the adjustable resistor on the Crt Termination Network.*

- Part 12 – Vertical Center
- Part 15 – Plug-in Interface Gains (Vertical Gain section only)
- Part 19 – Beam Registration (Perform Vertical section only)
- Enhanced Accuracy
- Part 24 – Install Instrument Covers
- Part 28 – Vertical High Frequency Response (Recheck performance with the covers on and the instrument warmed up.)
- Part 44 – Store Cal Constants
- Part 45 – Reset DIP Switches

## A1 Plug-In Interface Board

After the A1 Plug-In Interface board has been replaced according to the instructions in this section, the following checks should be performed:

1. Run the Extended Diagnostics (refer to Section 2).
2. Set DIP Switch number 4 on the A11 Main Processor board to its closed position. Refer to “Mainframe Preparation” in Section 2 for the location of this switch.
3. Install an 11000-Series plug-in in the left plug-in compartment. If an additional plug-in unit is available, install it in the center plug-in compartment.
4. Turn the instrument power on and wait for the self-test and new configuration adjustment processes to complete.
  - Select Enhanced Accuracy by pushing the front panel ENHANCED ACCURACY button twice. When the Enhanced Accuracy process is complete, check that the **Self calibration completed successfully** message appears on the screen.
  - If one plug-in unit is being used, move it to the center plug-in compartment. If two plug-in units are being used, move the center plug-in unit to the right plug-in compartment.
  - Run Enhanced Accuracy again and check for the **Self calibration completed successfully** message.
  - If one plug-in unit is being used, move it to the right plug-in compartment.
  - Run Enhanced Accuracy again and check for the **Self calibration completed successfully** message.

## A7 Touch Panel Board

After the A7 Touch Panel board has been replaced according to the instructions in this section, the following checks and adjustments should be made.

1. Follow the instructions in “Mainframe Preparation” in Section 2.
2. Perform the following checks and adjustments (as described in Section 2):
  - Part 3 – Touch Screen
  - Part 19 – Beam Registration
  - Enhanced Accuracy
  - Part 20 – Cursor to Graticule Match
  - Part 44 – Store Cal Constants
  - Part 45 – Reset DIP Switches

To verify the performance of the entire instrument, complete all the checks and adjustments presented in Section 2 in the normal sequence.

## A10 Front Panel Interface Board

After the A10 Front Panel Interface board has been replaced according to the instructions in this section, the following checks and adjustments should be performed.

1. Follow the instructions in “Mainframe Preparation” in Section 2.
2. Perform the following checks and adjustments (as described in Section 2):
  - Part 3 – Touch Screen
  - Part 19 – Beam Registration
  - Enhanced Accuracy
  - Part 20 – Cursor to Graticule Match
  - Part 22 – Front Panel Calibrator
  - Part 24 – Install Instrument Covers
  - Part 44 – Store Cal Constants
  - Part 45 – Reset DIP Switches

To verify the performance of the entire instrument, complete the entire Checks/Adjustments procedure as described in Section 2.



## A11 Main Processor Board

### NOTE

*Do not remove the A11 Main Processor board until it has been determined if the calibration constants can be saved.*

The A11 Main Processor board contains memory in which the instrument's calibration constants are stored. These constants should be saved, if possible, to speed up recalibration of the instrument when the board is replaced.

### Establishing a Set of Calibration Constants

The calibration constants can be saved by two methods (Method 1 and Method 2 below). The correct method depends on the particular situation.

If it is not possible to save the calibration constants, the default constants that are loaded into the memory of the replacement A11 Main Processor board may be used. Refer to Method 3.

If the calibration constants have been destroyed but there is no hardware failure of the A11 Main Processor board, a new set of calibration constants can be loaded. Refer to Method 4.

Select the method that is appropriate for your particular situation and follow the instructions for that method. After completing those instructions, refer to "Readjustment" which follows "Method 4."

### Method 1

This is the preferred method for situations in which either Method 1 or Method 2 can be used. In some instruments, the calibration constants can be physically removed from the original A11 Main Processor board and installed in the replacement board. The calibration constants are stored in a non-volatile memory (EEROM) IC (U800). This IC is mounted in a socket on the A11 Main Processor board. (In some earlier instruments U800 was soldered on the board. If this is the case, refer to Method 2.)



*Observe all special precautions mentioned under the heading "Static-Sensitive Device Classification" earlier in this section.*

If the calibration constants in the original A11 Main Processor board are believed to be good, remove U800 from the original board and install it in the replacement board.

To power up the replacement board, proceed as follows:

1. Install the new board and connect all the connectors.
2. With the instrument power off, remove the lithium battery (BT1190) from the new A11 Main Processor board and momentarily short across the terminals of the battery holder.
3. Replace the battery.
4. Set DIP switch numbers 2, 3, 4, and 5 on the A11 Main Processor board to their closed positions. Refer to "Mainframe Preparation" in Section 2 for the location of this switch.
5. Turn on the instrument and wait for the full power-up process to complete (approximately one minute).
6. Set DIP switch 2 on the A11 Main Processor board to its open position.
7. Adjust focus and astigmatism via the front-panel controls as required.

## Method 2

This method should be considered if Method 1 is not feasible. In order to use this method, communication with the original A11 Main Processor board must be possible through the RS-232 port.

In this method, calibration constants stored in the original A11 Main Processor board are transferred to a data file on the PC. The calibration constants are then transferred to the replacement board after it is installed in the mainframe.

To transfer the calibration constants from the original A11 Main Processor board to a data file, proceed as follows:

1. Set DIP switch number 5 on the A11 Main Processor board to its closed position. Refer to "Mainframe Preparation" in Section 2 for the location of the switch.
2. Select **utility** from the main menu of the PC.
3. Select the **dut\_const > file** test and follow the instructions on the screen. This test takes two to three minutes to complete. (Refer to Section 2 for additional information on this test.)

To transfer the data file to the replacement board, proceed as follows:

1. Install the new A11 Main Processor board. See the removal and replacement procedure in this section.
2. Set DIP switch numbers 2, 3, 4, and 5 to their closed positions. Refer to "Mainframe Preparation" in Section 2 for the location of this switch.
3. Turn on the instrument and wait for the full power up process to complete (wait about one minute). Set DIP switch number 2 to its open position.
4. Select **utility** from the main menu of the PC.
5. Select the **const\_file > dut** test and follow the instructions on the screen.
6. Press the DISP ADJ menu button on the 11301 and adjust the focus and astigmatism with the front-panel controls.

### Method 3

Replacement A11 Main Processor boards are shipped with the EEROM loaded with a default set of calibration constants. If Methods 1 and 2, as described above, are not usable, these default values are sufficient to begin the readjustment process.

To power up the instrument with a new A11 Main Processor board, proceed as follows:

1. Set DIP switch numbers 2, 3, 4, and 5 on the A11 Main Processor board to their closed positions. Refer to "Mainframe Preparation" in Section 2 for the location of this switch.
2. Turn on the instrument and wait for the full power up process to complete (wait about one minute). Set DIP switch number 2 to its open position.
3. Press the DISP ADJ menu button and adjust the focus and astigmatism with the front-panel controls.

### Method 4

If the A11 Main Processor board is functioning properly but has lost its calibration constants, it is possible to load a file of default calibration constants from a file located on the Calibration diskette.

1. Set DIP switch numbers 2, 3, 4, and 5 on the A11 Main Processor board to their closed positions. Refer to "Mainframe Preparation" in Section 2 for the location of this switch.
2. Connect the PC to the oscilloscope as described in Section 2.
3. Turn on the instrument and wait for the full power-up process to complete (wait about one minute). Set DIP switch number 2 to its open position.
4. Select **utility** from the main menu of the PC.
5. Select the **const\_file > dut** test. Follow the instructions on the screen and transfer the file named default.301. (For additional information on the file transfer program refer to Section 2.)
6. Press the DISP ADJ menu button and adjust the focus and astigmatism with the front-panel controls.

### Readjustment

If the calibration constants have been successfully saved, perform the following checks and adjustments (as described in Section 2):

- Extended Diagnostics
- Part 5 – A to D Converter
- Part 7 – Front Panel Display Adjustments
- Part 9 – Stored Waveform Vectors
- Enhanced Accuracy
- Part 24 – Install Instrument Covers
- Part 36 – Rear Panel Input/Output Signals
- Part 44 – Store Cal Constants
- Part 45 – Reset DIP Switches
- Set Clock and Calendar

If the calibration constants have not been saved, perform the following checks and adjustments (as described in Section 2):

- Extended Diagnostics
- Part 5 – A to D Converter
- Part 7 – Front Panel Display Adjustments
- Part 9 – Stored Waveform Vectors
- Part 15 – Plug-in Interface Gains
- Part 17 – Sweep Slew Rate Selfcal
- Part 18 – Sweep Gains
- Part 19 – Beam Registration
- Enhanced Accuracy
- Part 20 – Cursor to Graticule Match
- Part 22 – Front Panel Calibrator
- Part 23 – Intensity Settings
- Part 24 – Install Instrument Covers
- Part 25 – Sweep Timing Accuracy
- Part 32 – Trigger Sensitivity
- Part 33 – Trigger Accuracy
- Part 34 – Line Trigger
- Part 35 – Center Compartment X-Axis Accuracy
- Part 36 – Rear Panel Input/Output Signals
- Part 40 – 2 ns Holdoff
- Part 42 – Time Interval Using Sweeps
- Part 44 – Store Cal Constants
- Part 45 – Reset DIP Switches
- Set Clock and Calendar

To verify the performance of the entire instrument, complete all the checks and adjustments presented in Section 2 in the normal sequence.

---

## A12 Vertical Amp Board

Replace the A12 Vertical Amp board as described in the removal and replacement procedure in this section.

After replacing the board proceed as follows:

1. Adjust the focus and astigmatism with the front-panel controls.
2. Follow the instructions in “Mainframe Preparation” in Section 2.
3. Perform the following checks and adjustments as described in Section 2:
  - Part 7 – Front Panel Display Adjustments
  - Part 12 – Vertical Center
  - Part 15 – Plug-in Interface Gains (Perform only the Vertical Gain section)
  - Part 16 – Vertical Center (Second Pass)
  - Part 19 – Beam Registration (Perform only the **grat\_prep** adjustment using the PC)
  - Run the **autocal\_vert** test from the PC menu. When this test has completed, the readout display should be properly aligned to the Crt graticule.
4. To verify the performance of the A12 Vertical Amp board, perform the checks and adjustments (as described in Section 2) listed below:
  - Part 2 – Extended Diagnostics
  - Part 7 – Front Panel Display Adjustments
  - Part 10 – Spot Shift
  - Part 11 – Readout Jitter (Vertical section only)
  - Part 12 – Vertical Center
  - Part 15 – Plug-in Interface Gains (Vertical Gain section only)
  - Part 16 – Vertical Center (Second Pass)
  - Part 19 – Beam Registration (Perform Vertical section only)
  - Enhanced Accuracy
  - Part 20 – Cursor to Graticule Match
  - Part 22 – Front Panel Calibrator
  - Part 23 – Intensity Settings
  - Part 24 – Install Instrument Covers
  - Part 28 – Vertical High Frequency Response
  - Part 29 – Vertical/Measurement Accuracy
  - Part 36 – Rear Panel Input/Output Signals

- Part 44 – Store Cal Constants
- Part 45 – Reset DIP Switches

To verify the performance of the entire instrument, complete all the checks and adjustments presented in Section 2 in the normal sequence.

## A13 Scope Logic Board



*Do not turn the instrument power on after replacing the A13 Scope Logic board until you have read the following information.*

After the A13 Scope Logic board has been replaced according to the instructions in this section, the following adjustments and checks should be made.



*A bright dot may appear on the instrument's crt screen after the new A13 Scope Logic board has been installed. To avoid possible damage to the crt, adjust the grid bias (R952) to extinguish the bright dot when the instrument is turned on. Refer to "Display Quality" in Section 2 for the location of this adjustment. The final adjustment of R952 must be performed when the instrument has fully warmed up. For now, adjust R952 so that no trace or readout is visible when the character and trace intensities are set to their minimum values.*

1. Adjust the focus and astigmatism controls with the front-panel controls for the best display.
  - Adjust R1600 on the A13 Scope Logic board (refer to "Display Quality" in Section 2 of this manual for the adjustment location) for the clearest display.
  - Readjust the focus and astigmatism controls with the front-panel controls for the best display.
  - Repeat the previous adjustments until the display is usable.
2. Follow the instructions in "Mainframe Preparation" in Section 2.
3. Perform the following adjustments as described in Section 2:
  - Part 15 – Plug-in Interface Gains
  - Part 19 – Beam Registration (Perform only the **grat\_prep** adjustment using the PC.)
  - Run the **autocal\_vert** test from the PC menu. When this test has completed, the readout display should be properly aligned with the crt graticule.

4. To verify the performance of the A13 Scope Logic board, perform the checks and adjustments (as described in Section 2) listed below:
- Part 2 – Extended Diagnostics
  - Part 4 – CVR Accuracy
  - Part 6 – ACVS Gain
  - Part 7 – Front Panel Display Adjustments
  - Part 8 – Display Quality
  - Part 15 – Plug-in Interface Gains
  - Part 16 – Sweep Slew Rate Selfcal
  - Part 18 – Sweep Gains
  - Part 19 – Beam Registration
  - Enhanced Accuracy
  - Part 20 – Cursor to Graticule Match
  - Part 22 – Front Panel Calibrator
  - Part 23 – Intensity Settings
  - Part 24 – Install Instrument Covers
  - Part 36 – Rear Panel Input/Output Signals
  - Part 40 – 2 ns Holdoff
  - Part 42 – Time Interval Using Sweeps
  - Part 44 – Store Cal Constants
  - Part 45 – Reset DIP Switches

To verify the performance of the entire instrument, complete all the checks and adjustments presented in Section 2 in the normal sequence.

## A14 Time Base Board

After the A14 Time Base board has been replaced according to the instructions in this section, the following adjustments and checks should be made.

1. Adjust the focus and astigmatism controls with the front-panel controls for the best display.
2. Perform the following checks and adjustments (as described in Section 2):
  - Part 7 – Front Panel Display Adjustments
  - Part 13 – Magnified Registration
  - Part 15 – Plug-in Interface Gains (Perform only the Horizontal XY Gain section.)
  - Part 17 – Sweep Slew Rate Selfcal
  - Part 18 – Sweep Gains (Perform only the Adjustment section.)
  - Part 19 – Beam Registration (Perform only the **grat\_prep** adjustment using the PC.)
  - Run the **autocal\_vert** test from the PC menu. When this test has completed, the readout display should be properly aligned to the crt graticule.
3. To verify the performance of the A14 Time Base board, perform the checks and adjustments (as described in Section 2) listed below:
  - Part 2 – Extended Diagnostics
  - Part 6 – ACVS Gain
  - Part 7 – Front Panel Display Adjustments
  - Part 10 – Spot Shift
  - Part 11 – Readout Jitter (Horizontal section only)
  - Part 13 – Magnified Registration
  - Part 14 – XY Phase
  - Part 15 – Plug-in Interface Gains (Horizontal XY section only)
  - Part 17 – Sweep Slew Rate Selfcal
  - Part 18 – Sweep Gains
  - Part 19 – Beam Registration (Perform Horizontal section only)
  - Enhanced Accuracy
  - Part 20 – Cursor to Graticule Match
  - Part 21 – Reference Oscillator
  - Part 24 – Install Instrument Covers
  - Part 25 – Sweep Timing Accuracy



- Part 26 – Delta Delay Accuracy
- Part 27 – Probe Skew Range
- Part 29 – Vertical/Measurement Accuracy
- Part 30 – Trigger Filters
- Part 31 – Trigger Noise and Sensitivity
- Part 32 – Trigger Sensitivity
- Part 33 – Trigger Accuracy
- Part 34 – Line Trigger
- Part 35 – Center Compartment X-Axis Accuracy
- Part 36 – Rear Panel Input/Output Signals
- Part 37 – Counter Reference Clock In/Out
- Part 38 – Frequency Accuracy
- Part 39 – External A & B Input Sensitivity
- Part 40 – 2 ns Holdoff
- Part 41 – Holdoff By Events
- Part 42 – Time Interval Using Sweeps
- Part 43 – Minimum Time Interval
- Part 44 – Store Cal Constants
- Part 45 – Reset DIP Switches

To verify the performance of the entire instrument, complete all the checks and adjustments presented in Section 2 in the normal sequence.

## A15 Counter/Timer Reference Board

After the A15 Counter/Timer Reference board has been replaced according to the instructions in this section, the following adjustment (as described in Section 2) should be performed:

- Part 21 – Reference Oscillator

---

# Troubleshooting

---

This section provides the information necessary to troubleshoot a faulty instrument to the Field Replaceable Unit (FRU) level. In most cases an FRU is a circuit board. The primary means for troubleshooting is to use the error index code output from the Extended (Ext) Tests Diagnostics and cross-reference them to the suspect circuit boards in the FRU Guide tables below. After the faulty FRU is replaced, some recalibration of the instrument is normally required (this is discussed further below). In addition, other troubleshooting techniques are described at the end of this section to help identify a faulty crt, Crt Termination, Distributed Capacitance Plate, Power Supply Assembly, or Regulator board.

## Diagnostics Overview

Diagnostics are composed of two stages. The first is the Kernel Diagnostics that verifies the main processor and its associated hardware such as ROM, RAMs and control signals. After all the Kernel Diagnostics have passed without failure, the second-stage Self-Test Diagnostics run.

The Self-Test Diagnostics verify the remainder of the instrument circuitry. A Self-Test fault causes the instrument to enter Ext Test Diagnostics. The Ext Tests Diagnostics are a superset of the instrument's Self-Tests. These diagnostics allow selective, interactive testing.

Other Troubleshooting, at the end of this section, lists the circuits that Diagnostics do not fully test.

## Level 0: Kernel Diagnostics

The processor cannot execute code correctly with Kernel errors present. The Kernel Diagnostic output is used as a troubleshooting tool when repairing kernel faults. Once the kernel is functioning, the Self-Test Diagnostics and Ext Tests Diagnostics test the remainder of the instrument. For more information on power-up kernel failures, refer to Table 3-2.

## Level 1: Self-Test Diagnostics

The Self-Test Diagnostics consist of power-up diagnostic software routines that verify instrument functionality. The Self-Test Diagnostics are invoked automatically at power-up, manually with a front-panel menu, or externally through the GPIB and RS-232-C ports. Once invoked, these routines run automatically without operator intervention. If a test failure occurs, then the instrument ceases testing. Refer to GPIB/RS-232-C for external interface information.

**Kernel Verification**

Kernel verification is performed at power-up and can be invoked from the normal (non-power-up) operating mode.

**Power-Up Mode**

The instrument's resources may be severely limited at power up, so when diagnostic error information is output, it is in a very simple form. Diagnostic test errors are displayed with the front-panel MENU LEDs. When the diagnostic tests run without error, all the LEDs on the front panel MENU LEDs are off. If a fault is detected, two of the MENU's LEDs blink to identify the device causing the fault. Until any front-panel button is pressed, testing is halted. The two-LED device codes are given in Table 3-2 where a "\*" indicates a lit LED.

**Normal (Non-Power-Up) Mode**

In the non-power-up mode, the instrument has already powered-up and established that the Kernel is operational. When diagnostics are invoked in non-power-up situations, the tests run as described under Instrument Verification in this section.

**Instrument Verification**

Instrument Verification diagnostics are run with a high-level interface over one of the instrument's communication facilities.

**Power-Up Mode**

While the instrument's verification power-up tests are running, all the LEDs on the front panel are off; except during the routine that tests their operation.

If a fault is detected, the instrument halts testing and displays the Block menu (refer to Test Menu Examples in this section). The Block that failed is highlighted in the menu.

When all the tests are completed without a fault, the instrument powers-up normally.

**Normal (Non-Power-Up) Mode**

While the diagnostic tests are running, all the LEDs on the front panel are off; except again, during the routine that tests their operation.

When all tests are completed without a fault, the instrument responds to either of the following invocation sources:

- **Front Panel** – Touch the **Self-Test** entry in the **UTILITY** menu to invoke testing.

If the Self-Test Diagnostics pass, then the message **Self-Test completed successfully** is displayed. If the Self-Test Diagnostics fail, then the message **Self-Test failure** is displayed.

- **RS-232-C/GPIB** – Send the **TEST** command to the instrument to invoke the Self-Tests. The normal GPIB protocol of an SRQ with a status byte follows when testing is complete.

If the controller requires more information, it may send the **TEST?** query command. The instrument then returns either a **TEST PASS** or **TEST <index>** message. For detailed information on the GPIB/RS-232-C, refer to System Mode (GPIB and RS-232-C) in this section.

**TABLE 3-2**  
**Power-up Kernel Failure Codes**

MAJOR MENU LEDs							
DEVICE BEING TESTED			WAVEFORM		UTILITY	STR/RECL	DISPLAY
			TRIGGER	MEASURE			
							NUMERIC
DRAM U1620			*	*			
DRAM U1920			*		*		
DRAM U1600			*		*		
DRAM U1900			*			*	
DRAM CTRL U1500			*				*
RAM Addr & data line shorts			*				*
DRAM U1720						*	*
DRAM U1820						*	*
DRAM U1700					*		*
DRAM U1800			*				*
ROM U1200			*	*			
ROM U1430			*		*		
ROM U1300			*			*	
ROM U1400			*				*
ROM U1100				*	*		
ROM U1330				*		*	
ROM U1000				*			*
ROM U1230				*			*
BDRAM U1130					*	*	
BDRAM U900					*		*

---

## Level 2: Extended Tests Diagnostics

Extended (Ext) Tests Diagnostics consist of all Level 1 routines plus many additional routines. These additional routines include those requiring operator intervention and those considered too lengthy for the power-up sequence. Front-panel menu selections invoke the Ext Tests Diagnostic routines individually or in groups. Alternatively, you can connect an ANSI 3.64 compatible terminal to the RS-232-C port and use it to run the Ext Tests Diagnostics. The terminal displays the same menu selections as the front panel. The single key commands provide control that parallels the touch panel interface.

External System control is also available from a GPIB or RS-232-C controller. With system control, all the automatic tests are invoked at once. These diagnostics run similarly to the Self-Test Diagnostics; except that the testing continues after a fault is detected.

### Index Code Conventions

The diagnostics provide test index codes for rapid identification of a failed test. This code is then referenced to the appropriate test description. Index codes are constructed using the following conventions:

1. Each code is prefaced with a source ID: M, L, C, or R. M identifies the mainframe and L, C, and R identify the LEFT, CENTER, and RIGHT plug-ins, respectively.
2. The first hex digit identifies the test BLOCK.
3. The second hex digit identifies the test AREA.
4. The third hex digit identifies the test ROUTINE.
5. The fourth hex digit is for additional fault information that each ROUTINE uses.

### Front Panel

Front-panel control is possible only through the touch panel. The display shows both test menus and test status information. Refer to the Test Menu Examples that follow, for typical displays. To access the Extended Diagnostic menu, touch Ext Tests in the UTILITY menu.

Except during the routine that tests their operation, knobs and buttons are inactive during diagnostic operation. Also note that display integrity is intermittent during testing, since some tests disrupt the display.

Test Menu Examples

Figures 3-21 and 3-22 show sample displays of the Block and Area menus. Line numbers 1 through 16 were added on the right side of each example for reference.

BLOCK MENU				line #
BLOCK=Front Panel	AREA=All Areas	ROUTINE		1
				2
ALL BLOCKS	INDEX	FAULTS		3
Processor	pass			4
Front Panel	M2410	1		5
Scope Logic	pass			6
Timebase	pass			7
Vertical	pass			8
Left 11axxx	pass			9
Center 11axxx	pass			10
Right plug-in	R????			11
				12
				13
				14
on	off	off	off	15
VERBOSE	LOOP	HALT/ERR	RUN	16

6781-322

Figure 3-21. Block menu sample display.

AREA MENU				line #
BLOCK=Front Panel	AREA=Touch Panel	ROUTINE		1
				2
ALL AREAS	INDEX	FAULTS		3
Buttons	pass			4
Leds	pass			5
Knobs	pass			6
Touch Panel	M2410	1		7
FPCalibrator	pass			8
				9
				10
				11
				12
				13
				14
on	off	off	off	15
VERBOSE	LOOP	HALT/ERR	RUN	16

6781-323

Figure 3-22. Area menu sample display.

Test Menu Area

In Figures 3-21 and 3-22 the Test Menu Area is located from line 3 to line 14 on the display. Various menus use the Test Menu Area differently.

**Block and Area Menus**

Each line on the display is divided into the following three fields:

- Title
- Failure Code
- Failure Count

These fields are located on the display as shown in Figure 3–23.

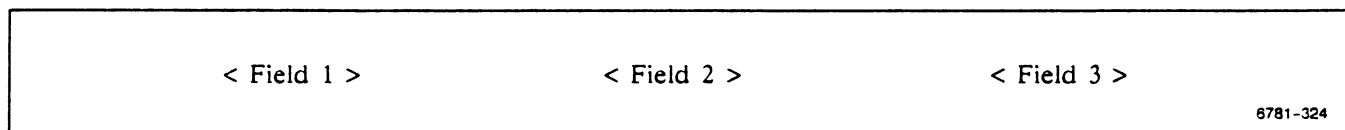

**Figure 3–23. Block and Area display fields.**

The following is a brief summary for each field shown in Figure 3–23.

**Field 1** This field contains Block and Area titles, which become highlighted when touched (selected).

The default selection is at the top of the list (ALL < tests > ).

**Field 2** This field is blank before a test is run. After the tests are complete, pass/fail code information is displayed. If no faults are detected pass is displayed. Field 2 is not touch-selectable.

If faults are detected, then ZNNNN (first error code) is displayed. The Z is an M for a mainframe fault and the L, C, or R variable is for the LEFT, CENTER, or RIGHT plug-in faults, respectively.

Z???? is displayed for plug-ins or options not installed.

Z---- is printed if a test returns NO pass or fail information.

**Field 3** This field displays the number of failures, nnnnn, that were accumulated during the last time that all or part of the Block or Area test was run. This field is not touch-selectable.

For Block menus, the displayed number indicates the number of failures that occurred during the last time that the Block test was run.

For Area menus, the displayed number indicates the number of failures that occurred during the last time that the Area test was run.

**Routine Menus**

Routine menus vary according to the tests performed, but some common features of all routine menus are:

**Field 1** The title field is the only touch-selectable field. This field is used to select a routine in the Block and Area menus.

**Fields 2, 3, 4, 6** These fields indicate the first error, if an error occurs. If no errors occur, then the information in these fields is from the last test.

**Field 5** This field is a decimal number and contains an accumulation of all the failures that the test recorded the last time it ran.

Although Routine menus vary depending on the application, there are four basic configurations: One for analog tests, two for digital tests, and one for memory tests.

**Analog and Digital Test Menus**

The unique features of the Analog and Digital Test Routine Menus follow, along with illustrations (refer to Fig. 3-24 and 3-25) showing the layout of their displays.

**Fields 2, 3, & 4** This field is either a hex or floating point number. This field displays the minimum and maximum test values allowed as well as the actual values.

**Field 6** This field contains an index code and uses the same format as the Block and Area menus.

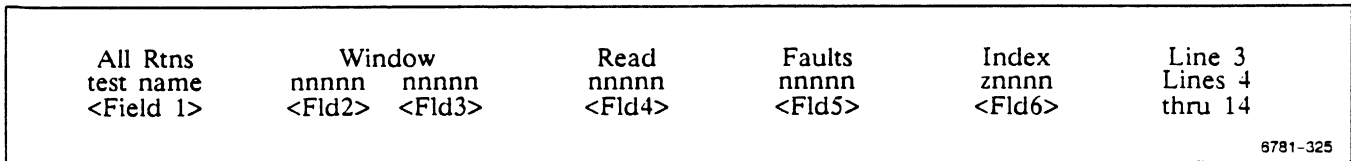

**Figure 3-24. Display of Analog Test Menu.**

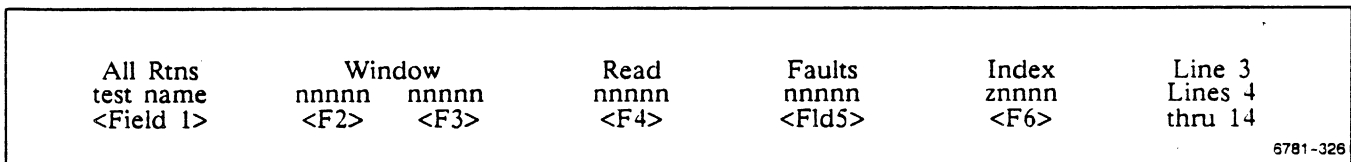

**Figure 3-25. Display of a Plug-in Digital Test Menu (plug-in diagnostics only).**

**Mainframe Digital Test Menu**

The unique features of the Mainframe Digital Test Routine Menu follow, along with an illustration (refer to Fig. 3-26) showing its layout of the display.

**Field 2** This field is a hex number indicating the desired test results.

**Field 3** This field is a hex number indicating the test deviation allowed from the desired value (Field 2).

**Field 4** This field is a hex number indicating the actual test result.

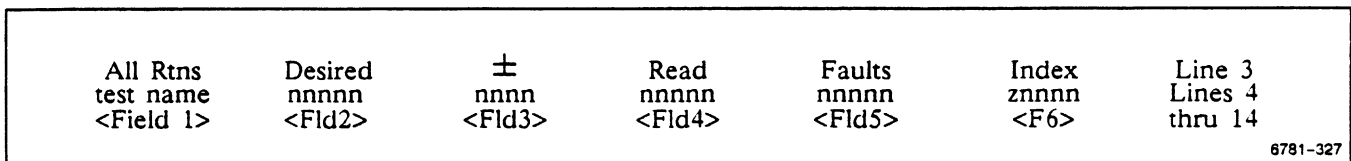

**Figure 3-26. Display of Mainframe Digital Test Menu.**



### Memory Test Menu

The unique features of the Memory Test Routine Menu follows, along with an illustration (refer to Fig. 3-27) showing the layout of its display

**Field 2** This field is a hex number indicating the address of the test.

**Field 3** This field is a hex number indicating the desired value. This is normally the value written.

**Field 4** This field is a hex number indicating the actual value read.

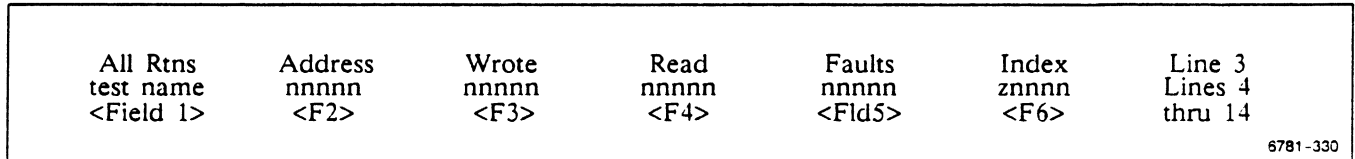

**Figure 3-27. Display of Memory Test Menu.**

### Test Status Area

The Test Status areas are located at the top and bottom of the display on lines 1, 15, and 16. All the diagnostic menus use the Test Status Area in the same way. Figure 3-28 shows the display location of fields in the Test Status areas.

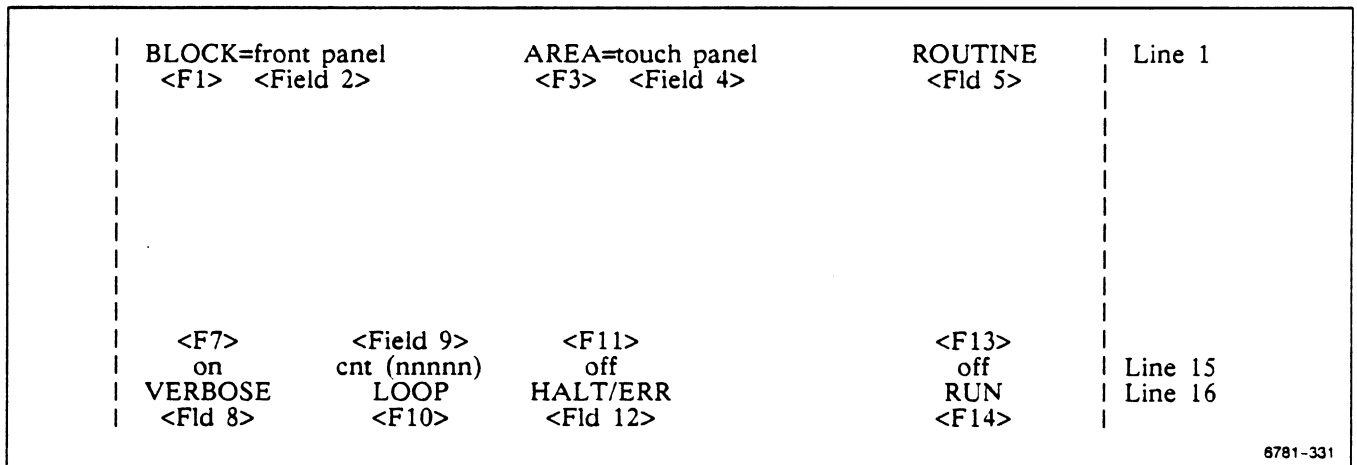

**Figure 3-28. Test Status areas of the display.**

The display fields shown in Figure 3-28 are used as follows:

- Field 1** This field displays the diagnostic Block menu and highlights the field, when touched.
- Field 2** This field displays the name of the current Block Menu selection. The Block title is truncated if it is too long for the field. Field 2 is not touch-selectable.
- Field 3** This field displays the selected Block's diagnostic Area menu and highlights the field, when touched. If no Block was previously selected, then you will be prompted to select a Block.
- Field 4** This field displays the name of the current Area Menu selection. The name is truncated if it is too long for the field. Field 4 is not touch-selectable.

**Field 5** This field highlights when touched and displays the selected Area's diagnostic Routine menu. If no Area was previously selected, you will be prompted to select an Area.

**NOTE**

*The Routine menu may have empty fields until the test has run.*

**Field 7** This field displays the current selection of **VERBOSE** (**on** or **off**).

**Field 8** This field is touch-selectable and causes **VERBOSE** to toggle between **on** and **off**. If the current selection is **on** then new test information is displayed in the Test Menu Area or output through a port, whichever is applicable. If the current selection is **off**, then no new test information is displayed until testing stops. This is useful when using the test as a scope loop.

**Field 9** This field displays the current selection of **LOOP** (**off** or **cnt nnnnn**).

**Field 10** This field is touch-selectable and causes **LOOP** to toggle between **on** and **off**. If **off** is displayed, the currently selected Block Area or Routine runs only once. If **on** is displayed, the currently selected Block, Area, or Routine runs repeatedly when directed to run. The loop count is displayed in Field 9.

**Field 11** This field displays the current selection of **HALT/ERR** (**on** or **off**).

**Field 12** This field is touch-selectable and causes **HALT ON ERROR** to toggle between **on** and **off**. If **on** is displayed in Field 11, then the currently selected Block, Area, or Routine stops running when an error is detected. If **off** is displayed, the Block, Area, and Routine menus record the error and permit testing to continue.

**Field 13** This field displays the current selection of **RUN** (**on** or **off**).

**Field 14** This field is touch-selectable and causes **RUN** to toggle between **on** and **off**. If **on** is selected, the currently selected Block, Area, or Routine tests run. If **off** is selected, testing stops.

## **GPIB/RS-232-C**

The GPIB interface is used in the System Mode only. The Diagnostic Terminal mode provides fully functional diagnostics to the user while the System mode excludes all interactive testing. The RS-232-C interface is used in either of two modes for Ext Tests Diagnostics. The first mode is the System mode, where the RS-232-C emulates GPIB codes and formats. The second mode is the Diagnostic Terminal mode. For example, this mode could use the RS-232-C to drive a terminal, providing diagnostic menus on the terminal.

---

**System Mode  
(GPIB & RS-232-C)**

System mode communication follows GPIB codes and formats. All interactive tests are excluded from System operation mode; therefore, a method of aborting a test in progress is not provided.

**Test Commands**

The following command syntax is used in the System mode:

**TEST TERMINAL** – This command redirects diagnostics menus to the RS-232-C interface.

**TEST** – This command performs Self-Test Diagnostics on the complete mainframe and plug-in combination (Halts upon Error).

**TEST EXTENDED** – This command performs Ext Tests Diagnostics on the complete instrument.

**TEST?** – This query returns one of following ASCII strings:

- TEST PASS
- TEST “M <index>”, “L <index>”, “C <index>”, “R <index>” (The index numbers are in the order of occurrence.)

For example, the query may return this ASCII string in the following format:

**TEST “M2345”, “M2352”, “M4510”, “L1234”, “R1234”**

which contains the mainframe tests indexed by 2345, 2352, and 4510; the Left plug-in test indexed by 1234; and the Right plug-in test indexed by 1234.

**Diagnostic Terminal Mode (RS-232-C)**

A service technician uses the Diagnostic Terminal mode as the primary diagnostic I/O method. In this mode, menu selections can be made on the front-panel and on the Diagnostic Terminal simultaneously.

The diagnostic test menus are displayed on the Diagnostic Terminal exactly as they appear on the instrument display. Menu selections are made with the terminal keyboard commands to simulate display touches. Each keyboard command only requires a single key stroke, instead of the full command words used in the System mode.

**Terminal Interface**

The Terminal Interface uses the ANSI X3 control.

**Invocation Command**

**TEST TERMINAL** – This command switches the RS-232-C interface to Diagnostic Terminal mode and places the instrument in the Ext Tests Diagnostics mode.

**Terminal Diagnostic Commands**

- A|a** This command is equivalent to touching the AREA field on the display menu.
- B|b** This command is equivalent to touching the BLOCK field on the display menu.
- D|d** This command is equivalent to moving your finger down the left side of the display's test selection list.
- E** This command is equivalent to touching the front-panel UTILITY major menu button and takes the instrument out of Ext Tests mode.
- H|h** This command is equivalent to touching the HALT/ERROR field in the status area.
- L|l** This command is equivalent to touching the LOOP field in the status area.
- R|r** This command is equivalent to touching the ROUTINE field on the display menu.
- S|s** This command is equivalent to touching the RUN or START/STOP field in the status area.
- U|u** This command is equivalent to moving your finger up the left side of the display's test selection list.
- V|v** This command is equivalent to touching the VERBOSE field in the status area

## New Configuration Calibration

When a plug-in is first installed in a mainframe or when it is moved to a different compartment in the mainframe, the instrument is in a new configuration mode. After the instrument runs the Power-Up Diagnostics, it recalibrates itself for the new configuration. During this calibration, the message **Powerup new configuration partial calibration occurring** appears at the top of the display. If the calibration is successful (as indicated by a message), then the instrument enters the normal operating mode.

## Restoring Calibration Data from EEROM

If the battery-backed RAM (BDRAM) is corrupted, then if any of the following conditions occur, you may need to use the following procedure:

- The instrument “locks-up” and does not unfreeze after being repowered (turning the power off and then on again)
- The display is poorly aligned, and running Enhanced Accuracy (EA) does not correct the misalignment
- EA fails repeatedly
- Autoset is not functioning
- Other conditions that significantly deviate from normal operation

### Procedure

If any of these conditions occur, then using the following procedure usually restores normal operation:

1. Turn the power off
2. Remove the top cover of the mainframe
3. Remove the battery from the A11 Main Processor board
4. Short the battery holder with a shorting strap for five seconds
5. Remove the wire clip
6. Reinsert the battery (observing the correct polarity)
7. Replace the top cover of the mainframe
8. Turn the power on

Usually this procedure restores normal operation. If this procedure does not restore normal operation, then your instrument requires servicing.

## Field Replaceable Unit (FRU) Guide

This section correlates all possible error codes resulting from Diagnostic tests with the primary and secondary board(s) suspected of causing each error. You should inspect the primary suspect board for loose connections or components. Then, if the Diagnostic errors are repeated, replace it with a known good board. Check that the new board is configured exactly like the old one and that any installed firmware matches the version in the old board. Refer to Section 2, Checks and Adjustments, for any necessary adjustments, calibrations, or precautions.

### Abbreviations of FRU Names

All active mainframe boards are listed here with the abbreviations used in the FRU tables below.

PIINT	Plug-In Interface board	(A1)
FPASS	Front Panel Assembly	(A5)
TOUCH	Touch Panel board	(A7)
FPINTR	Front Panel Interface board	(A10)
MPU	Main Processor board	(A11)
VERT	Vertical Amp board	(A12)
SCLOG	Scope Logic board	(A13)
TB	Time Base board	(A14)
CTR	Counter Timer Reference board	(A15) Opt 1T
FW	Firmware (proms)	(FW)
EEROM	EEROM IC	(A11U800)
SDI	Serial Data Interface IC	(A11U1760)
DISLAY	Display IC	(A11U440)
BATT	Battery	(A11Bt1190)
ROCS	Real Time Oscillator Control IC	(A13U270)
ACVS	Analog Control Voltage Processor	(A13U750)
TRC	Trace Rotation Coil	(L53)

### Abbreviations of Component and Module Names

All active components and modules are listed here with the abbreviation used in the FRU tables below.

CRT	(V53)
Crt Termination	(R80)
FAN	(A21A)
FUSE1	(A2F99)
FUSE2	(A13F560)
Power Supply Assembly	(A2)
Regulator board	(A4)

## Extended Diagnostic Error Index Codes

This section provides listings in numeric order of all test error codes that the Ext Tests Diagnostics generate. The method for reading these error codes is described under Level 2: Extended Tests Diagnostics Index Code Conventions, in this section.

The Ext Tests Diagnostics menu and the failure error codes (of the failed circuit block) appear on the screen after the first test failure. The first error code encountered and the total number of faults in that circuit block also appears with the failed circuit block name. For a more complete list of error codes in a block: first select the label of the failed block, and then select the Area label. To display the lowest level routines in that selected Area, select the Routine label.

The error code indicates the first test that failed. The last test to pass, prior to the first failed test, can be useful in isolating the problem.

Table 3-3 lists the Ext Tests Diagnostics error index codes.

**TABLE 3-3**  
Extended (Ext) Tests Diagnostics Error Index Codes

Error Index	Primary Suspect	Secondary Suspect
M11XX	FW	MPU
M121X-M123X	SDI	MPU
M124X-M126X	MPU	PIINTR, plug-in
M127X	MPU	SCLOG, TB
M131X-M132X	MPU	
M133X-M134X	EEROM,	MPU
M14XX	MPU	
M15XX	MPU	FPINTR, SCLOG, TB, VERT
M161X-M163X	MPU	
M164X	MPU	TOUCH, FPINTR
M17XX	MPU	
M18XX	DISPLAY	MPU
M191X-M192X	MPU	
M195X	MPU	
M1AXX	BATT	MPU
M211X-M224X	FPASS	FPINTR, MPU
M25XX	FPINTR	SCLOG, MPU
M31XX	ROCS	SCLOG, MPU
M321X-M327X	SCLOG	MPU
M328X	SCLOG	TRC, MPU
M329X	SCLOG	MPU
M33XX-M34XX	SCLOG	MPU
M41XX-M481X	TB	SCLOG, MPU
M482X-M483X	TB	MPU, SCLOG
M484X-M493X	TB	SCLOG, MPU
M51XX-M531X	VERT	SCLOG, MPU
M532X	VERT	MPU, SCLOG
M533X-M534X	VERT	MPU, SCLOG, plug-in
M535X	VERT	SCLOG, MPU
M536X	VERT	TB, SCLOG, MPU

## Enhanced Accuracy Mode Troubleshooting

If the oscilloscope fails to successfully complete the Enhanced Accuracy (EA) process, then note the message that appears on the screen when the failure occurs. Next, from the UTILITY menu run the Extended (Ext) Tests Diagnostics. When this process has completed note any failures that occurred.

If any failures did occur during Ext Tests, it is possible that these failures are related to the failure that occurred during the EA process. The fault information associated with the Ext Tests failure should be used in conjunction with the table that follows to determine the most probable problem area.

When a failure occurs during EA, the instrument: aborts the adjustment process, displays the error message, and returns to normal operating mode. Knowledge of the order in which EA adjustments occur can also be used as an aid in locating problem areas. Table 3-4 lists the adjustment procedures made in the EA process.

**TABLE 3-4**  
**Enhanced Accuracy Adjustment Process**

<b>Adjustment</b>	<b>Indication</b>
align the electron beam to the crt graticule lines in the vertical axis	bright pairs of lines appear on the screen (refer to A1 and A2 in Fig. 3-29)
mainframe vertical amplifier gain	two short bars appear on the screen (refer to B in Fig. 3-29)
readout/cursor gain and offset in the vertical axis	<sup>1</sup> two dots appear on the screen (refer to C in Fig. 3-29)
align the electron beam to the crt graticule lines in the horizontal axis	bright pairs of lines appear on the screen (refer to D1 and D2 in Fig. 3-29)
horizontal X1 amplifier gain	two short bars appear on the screen (refer to E in Fig. 3-29)
readout/cursor gain and offset in the horizontal axis	<sup>1</sup> two dots appear on the screen (refer to F in Fig. 3-29)
horizontal X10 amplifier gains for the main and delayed sweeps	two short bars appear on the screen (refer to E in Fig. 3-29)
mainframe gain for the center plug-in x-axis deflection	two dots appear on the screen (refer to F in Fig. 3-29)
mainframe gain for the right plug-in x-axis deflection	two dots appear on the screen (refer to F in Fig. 3-29)
trace separation for the left, center, right (xy) left + center and center (xy) (if plug-ins are present)	happens too quickly to see

<sup>1</sup>This process is called twice because of interaction between readout gain and offset.



**TABLE 3-4 (cont)**  
**Enhanced Accuracy Adjustment Process**

Adjustment	Indication
left plug-in (if present) adjusts its own gains and balances	horizontal traces move up and down on screen (refer to G in Fig. 3-29)
center plug-in (if present) adjusts its own gains and balances	horizontal traces move up and down on screen (refer to G in Fig. 3-29)
right plug-in (xy) (if present) adjusts its own gains and balances	dots move left and right on screen (refer to F in Fig. 3-29)
slew rate of the main and delayed sweeps	the message: <b>Enhanced Accuracy in Progress</b> appears on the screen
	the message disappears from the screen
center plug-ins (xy) (if present) gains and balances, adjusted in mainframe	dots move left and right on the screen (refer to F in Fig. 3-29)
trace separation for the left, center, right (xy) left + center and center (xy) (if plug-ins are present)	happens too quickly to see
left plug-in (if present) trigger calibration, adjusted in mainframe	dot or line moves about on the screen (refer to H in Fig. 3-29)
center plug-in (if present) trigger calibration, adjusted in mainframe	dot or line moves about on the screen (refer to H in Fig. 3-29)
right plug-in (if present) trigger calibration, adjusted in mainframe	dot or line moves about on the screen (refer to H in Fig. 3-29)

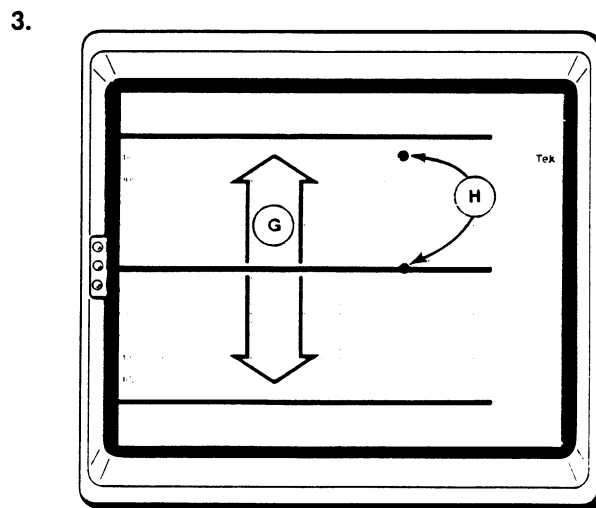
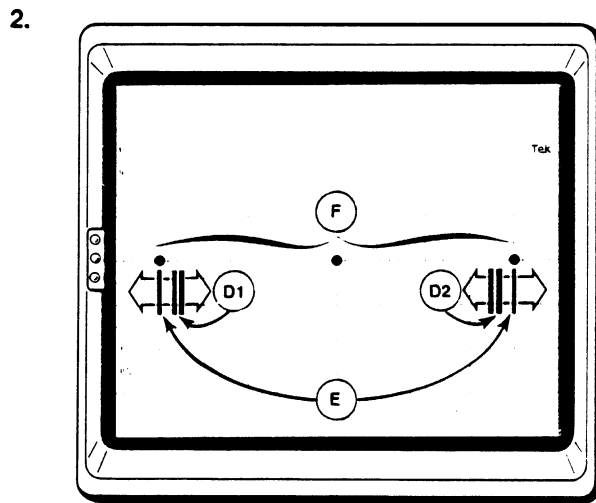
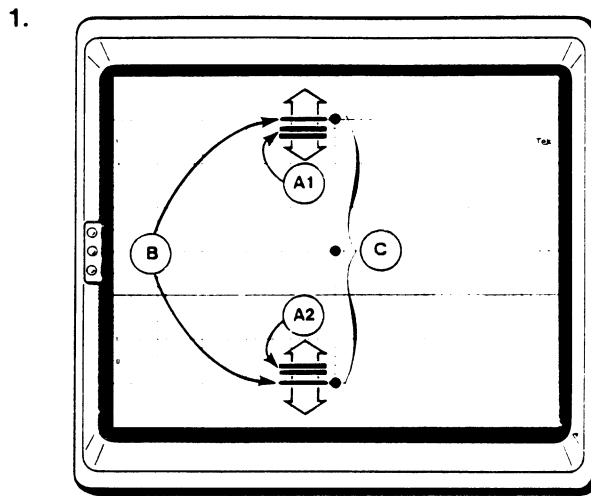

6781-328

Figure 3-29. Enhanced Accuracy adjustment procedure.

Table 3-5 lists the error messages that are possible in the Enhanced Accuracy mode. If these error messages occur, first attempt to perform the Checks and Adjustments procedure parts listed under Suggested Adjustments. If the error messages still occur, then replace, as appropriate, the boards listed under Suggested Troubleshooting. Enhanced accuracy is available after the system has a 20-minute warmup period.

**TABLE 3-5**  
**Enhanced Accuracy Mode Error Messages and Troubleshooting**

<b>Error Message</b>	<b>Suggested Adjustments</b>	<b>Suggested Troubleshooting</b>
<b>Mainframe amplifier calibration failed</b>	Perform the adjustments in Section 2, Checks and Adjustments Part 6 – ACVS Gain Part 12 – Vertical Center Part 13 – Magnified Registration Part 15 – Plug-in Interface Gains Part 18 – Sweep Gains Part 19 – Beam Registration Part 20 – Cursor to Graticule Match	Reload calibration constants from EEROM. Replace the A10 Front Panel Interface board, the A11 Main Processor board, the A14 Time Base board, and/or the A13 Scope Logic board.
<b>Left plug-in calibration failed</b>	Perform the adjustments in Section 2, Checks and Adjustments Part 12 – Vertical Center Part 15 – Plug-in Interface Gains Part 19 – Beam Registration Part 20 – Cursor to Graticule Match	Replace the Left plug-in, the A12 Vertical Amp, and/or the A1 Plug-in Interface board.
<b>Center plug-in calibration failed</b>	Perform the adjustments in Section 2, Checks and Adjustments Part 12 – Vertical Center Part 15 – Plug-in Interface Gains Part 19 – Beam Registration Part 20 – Cursor to Graticule Match	Replace the Center plug-in, the A12 Vertical Amplifier, and/or the A1 Plug-in Interface board
<b>Right plug-in calibration failed</b>	Perform the adjustments in Section 2, Checks and Adjustments Part 15 – Plug-in Interface Gains Part 19 – Beam Registration Part 20 – Cursor to Graticule Match	Replace the Right plug-in, the A14 Time Base board, and/or the A1 Plug-in Interface board
<b>Trace separation calibration failed</b>	No adjustments to perform	Replace the A12 Vertical Amp board and/or the A11 Main Processor board
<b>Trigger calibration failed</b>	No adjustments to perform	Replace the A14 Time Base board, the A13 Scope Logic board, and/or the A1 Plug-in Interface board
<b>Sweep calibration failed</b>	No adjustments to perform	Replace the A14 Time Base board and/or the A13 Scope Logic board

**TABLE 3-5 (cont)**  
**Enhanced Accuracy Mode Error Messages and Troubleshooting**

<b>Error Message</b>	<b>Suggested Adjustments</b>	<b>Suggested Troubleshooting</b>
<b>Sweep position calibration failed</b>	Perform the adjustments in Section 2, Checks and Adjustments Part 13 – Magnified Registration Part 17 – Sweep Slew Rate Selfcal Part 18 – Sweep Gains Part 19 – Beam Registration Part 20 – Cursor to Graticule Match	Replace the A14 Time Base board and/or the A13 Scope Logic board
<b>XY amplifier calibration failed</b>	Perform the adjustments in Section 2, Checks and Adjustments Part 13 – Magnified Registration Part 15 – Plug-in Interface Gains Part 19 – Beam Registration Part 20 – Cursor to Graticule Match	Replace the A14 Time Base board and/or the A13 Scope Logic board
<b>COUNTER: Waiting to Start Measurement</b>	Perform the adjustments in Section 2, Checks and Adjustments Part 42 – Time Interval Using Sweeps	Replace the A14 Time Base board
<b>COUNTER: Waiting to Finish Measurement</b>	Perform the adjustments in Section 2, Checks and Adjustments Part 42 – Time Interval Using Sweeps	Replace the A14 Time Base board

## Other Troubleshooting

### Crt

This procedure requires a Test Terminal with an RS-232-C

#### **Module Troubleshooting**

Crt failures may exhibit a variety of symptoms: display malfunctions, intermittent operation, performance defects, or physical defects. However, crt-related circuitry may cause similar symptoms. You should be sure to eliminate any other possible causes of failure before replacing the crt. To replace the crt requires extensive mainframe recalibration and performance verification.

#### **No Display**

If there is no display of either the readout characters or the traces, it may be the result of a power supply failure, a z-axis failure, a deflection amplifier failure, crt high voltage failure, or a problem in the crt itself.

Run the diagnostics using the Test Terminal. If failures occur, investigate the trouble areas indicated.

If diagnostics pass, perform the following tests to locate the problem area:

1. Press the Beamfind button and increase the CHAR intensity to its maximum value.

If a display is visible it is an indication that the crt is receiving some of its voltages and that parts of the deflection amplifiers are operational.

If no display is visible then the beam may be deflected off the screen due to a deflection amplifier failure or a poor connection in the deflection path. Diagnostics cover a major portion of the deflection amplifier circuits, but may not detect some faults. For example: if a deflection lead or termination is open, then it may not report a diagnostic failure.

2. Inspect the leads that connect from the horizontal and vertical deflection amplifiers to the crt neck pins. Two leads connect the horizontal deflection neck pins of the crt to the A14 Timebase board. The vertical deflection system uses two pairs of neck pins on the crt. One pair connects directly to the A12 Vertical Amp board and the other pair connects to the Crt Termination.
3. Check the F560 fuse for the high-voltage system which is located on the A13 Scope Logic board (refer to Fig. 3-30 for the location of this fuse). Replace the fuse if necessary.

The diagnostics do not cover the grid-bias circuit on the A13 Scope Logic board. Therefore, you need to refer to the Display Quality test in Section 2 Checks and Adjustments for the adjustment instructions.

4. You may also check the voltages at the socket at the end of the crt and at the crt neck pins.



*Dangerous voltages are present on the crt connectors and the A13 Scope Logic board.*

To measure the crt neck pin voltages, turn the instrument power off and remove the panel behind the crt. Remove the protective plastic cover on the crt socket. Then, turn the instrument on again.

You must use a special high voltage probe to measure these voltages. Measure the voltages on the crt socket and check that these voltages are similar to the approximate values shown in the table below. Also measure the voltages at TP1510 and TP1610 on the A13 Scope Logic board (refer to Fig. 3-30 for the location of these jumpers). To get access to these connectors, remove the protective high voltage cover.

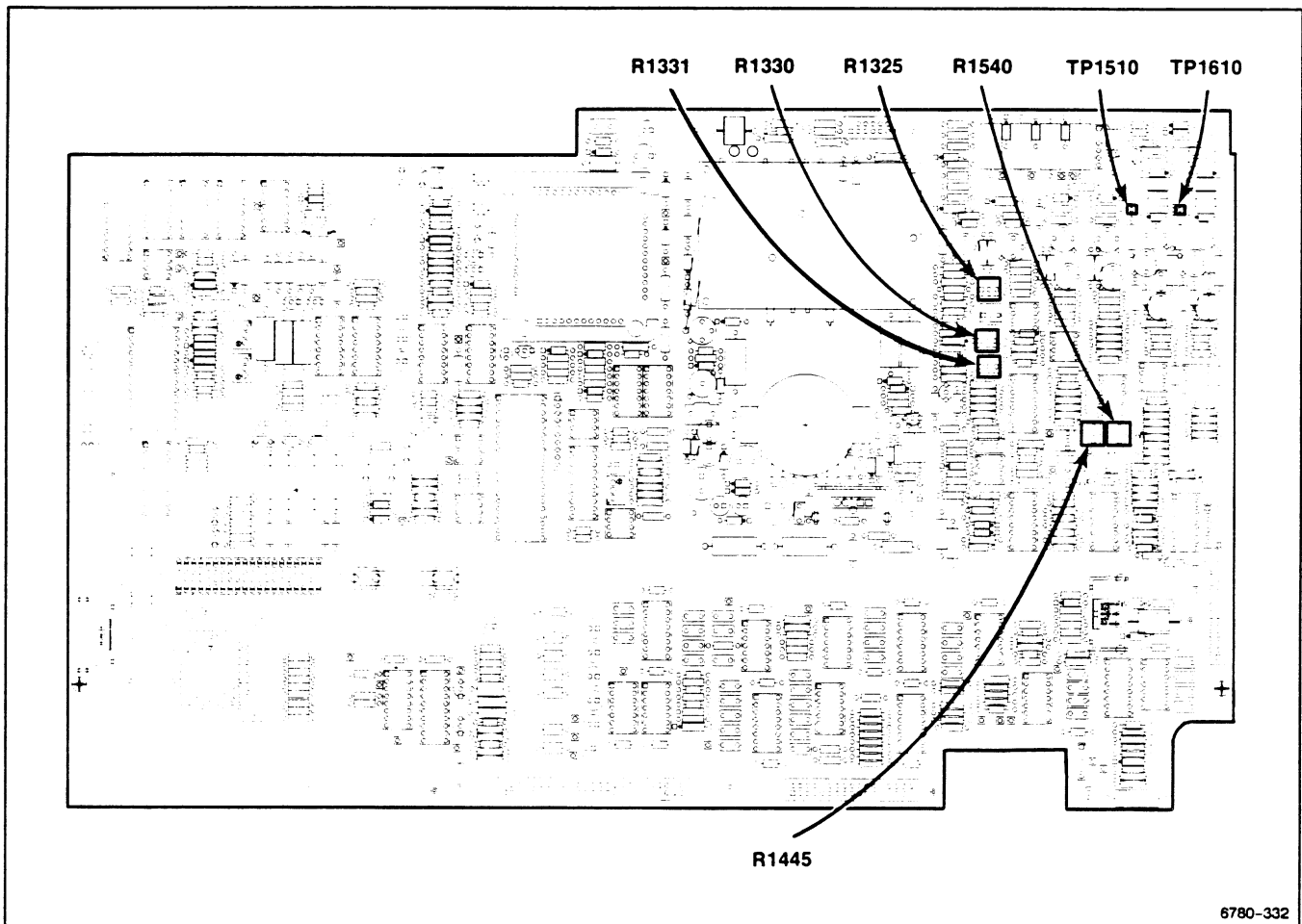

**Figure 3-30. A13 Scope Logic board test point, resistor, and fuse locations.**

**NOTE**

*All the following voltages are referenced to ground.*

- Pin 1: -1910 VDC
- Pin 2: -1910 VDC
- Pin 3: -1930 to -2000 VDC (varies with intensity)
- Pin 4: -480 VDC
- Pin 5: 8.5 to 60 VDC (varies with intensity)<sup>1</sup>
- Pin 6: 2.4 to 18 VDC (varies with intensity)
- Pin 7: 85 to 135 VDC (varies with R1540 geometry)<sup>2</sup>
- Pin 8: 14 to 39 VDC (varies with R1331 stigmator)
- Pin 9: 30 VDC

- Pin 10: -25 to -125 VDC (varies with R1325 geometry)
- Pin 11: -100 VDC<sup>1</sup>
- Pin 12: -255 to -317 VDC (varies with FP focus)<sup>1</sup>
- Pin 13: -184 to -245 VDC (varies with FP Astigmatism setting)<sup>1</sup>
- Pin 14: -1910 VDC heater
- TP1510: 85 to 165 VDC (depends on R1540 and R1445)
- TP1610: 85 to 165 VDC (depends on R1540 and R1445)

<sup>1</sup> The voltages at these pins are checked by the diagnostics.

<sup>2</sup> Turn the Readout Intensity off before measuring the voltage at this pin.

If no high voltage is present, then the problem may be a blown fuse (F560 on the A13 Scope Logic board), defective circuitry in the high voltage section of the A13 Scope Logic board, or defective low voltage power supply assembly, refer to Figure 3-30 for the location of F560.

If all voltages appear reasonable and there is no display, then the problem may be an open heater in the crt or an open circuit in the filament-winding path from the high-voltage transformer to the crt heater. The heater voltage is approximately 6.3 VAC, elevated to -1900 VDC.

If any voltage is obviously wrong it is most probable that the A13 Scope Logic board is at fault. However, it is possible that a short between elements within the crt could also cause the voltages to be out of range.

## Display With No Intensity Control



*To avoid crt damage, do not leave the instrument on any longer than necessary when troubleshooting this condition. Position the beam off the screen if possible.*

A possible failure that occurs in crt's is a G-K short. This is a short or low impedance between the grid and cathode. As a result of this condition, the grid and cathode are at nearly the same voltage. A symptom of this condition is a very bright trace that can not be adjusted using the front-panel intensity controls. Other failures can result in the same symptom and the crt can be damaged as a result.

If the display intensity is visible but not exceedingly bright (still without control), then the problem is most likely in either the z-axis circuitry or ACVS circuitry on the A13 Scope Logic board. The Extended test diagnostics provide good coverage of these areas.

Poor Edge Focus/Astigmatism Diagnostics cover most of the focusing/Q-axis circuitry. Refer to Crt Display in Section 2 checks and Adjustments, for adjusting the display. If this circuitry is at fault, then the crt should be replaced.

## Intermittent Display

When the crt's ground connection deteriorates (possibly due to loose hardware), the display increases or decreases in size and then rapidly returns to normal. If this behavior happens repeatedly, then check for loose connections in the hardware.

## Crt Termination

### NOTE

*Do not disturb any of the circuitry on the A12 Vertical Amp board (such as the leads or the adjustable components). If you disturb any of this circuitry, then extensive vertical recalibration will be required.*

The Crt Termination hybrid (see Fig. 3-31) is a laser-trimmed resistor network that is mounted to the chassis near the A12 Vertical Amp board. A Digital Multimeter (DMM) can effectively check this component with the instrument turned off.

### Module Troubleshooting

This component is suspect if the display on the crt screen is badly unbalanced vertically. Also, inspect the connection of this component to the crt neck pins as follows:

1. Turn the instrument power off
2. Unplug the cable from J80 on the A12 Vertical Amp board (refer to Fig. 3-31 for the location of this jumper)
3. Unplug the two leads that connect the termination hybrid to the crt neck pins
4. Set the DMM for measuring resistance
5. Put one lead of the DMM on pin 4 of J80
6. Carefully put the other lead of the DMM on the solder joint of either wire connecting the crt neck pins solders to the Crt Termination hybrid
7. Check that the resistance measured is between 180 and 205  $\Omega$
8. Leave one lead of the DMM on pin 4 and move the other lead of the DMM to the other wire connecting the crt neck pin solders to the Crt Termination hybrid (refer to step 6)
9. Check that the resistance measured is between 125 and 150  $\Omega$

### NOTE

*The two resistance values measured in steps 7 and 9 should be within 2% of each other. Also, many test leads that are used with DMMs have a varying amount of resistance error. You must account for these variations in the measurement of all resistances.*

10. With one lead of the DMM still on pin 4 of J80, touch the other lead of the DMM to pin 5 of J80
11. Check that the resistance measured is 1.00 M $\Omega$   $\pm$ 3%



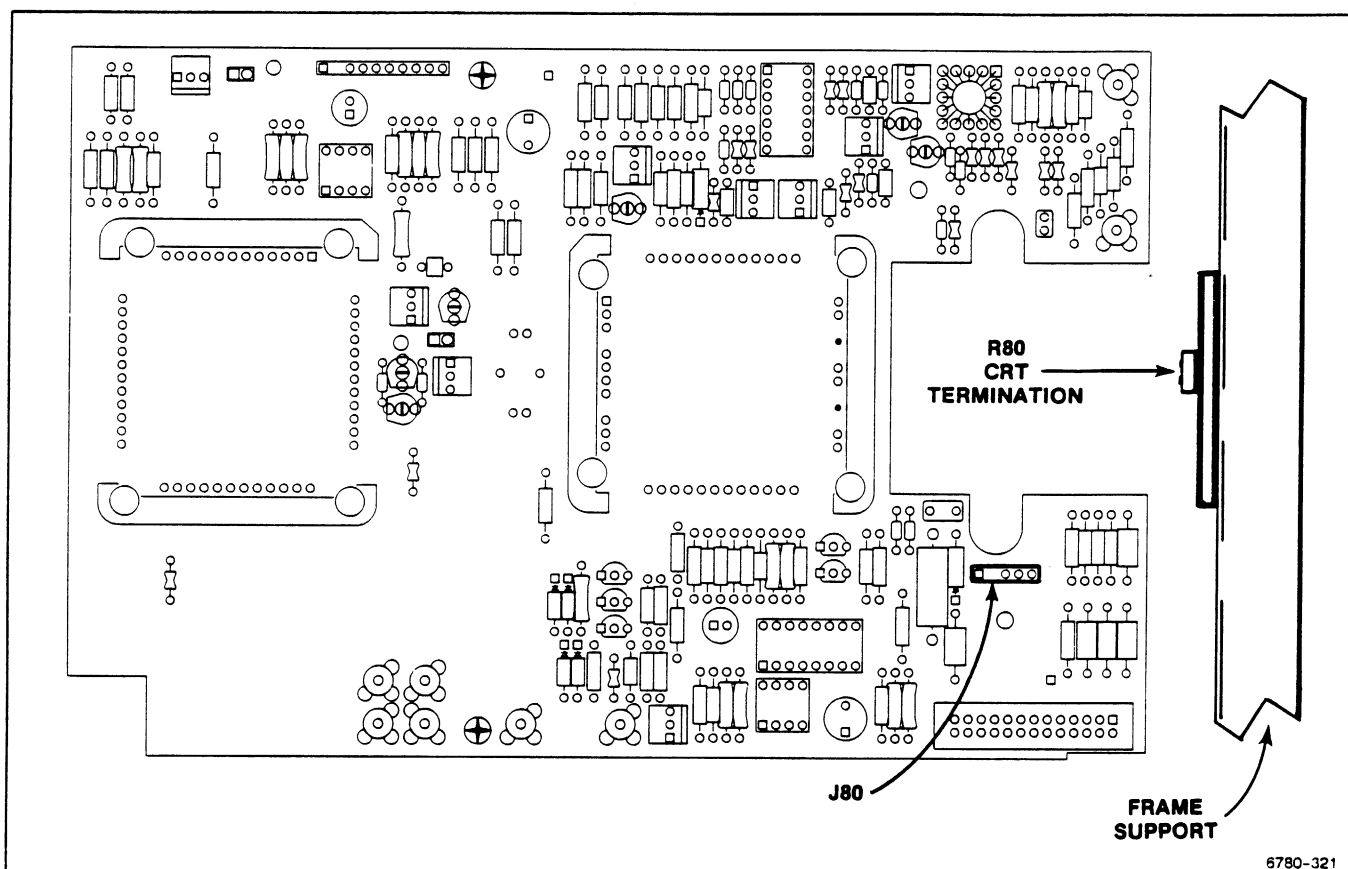

6780-321

**Figure 3-31. Crt Termination.**

12. Move the lead on pin 5 to pin 3 of J80
13. Check that the resistance measured is  $1.00 \text{ M}\Omega \pm 3\%$

**NOTE**

*The two resistances values measured in steps 11 and 13 should be within 0.5 % of each other.*

## Power Supply Assembly

This procedure requires an Extended Diagnostics Power Supplies Test Fixture. Refer to Table 2-1 for a complete description of the equipment required.

### Module Troubleshooting

Power supply problems show up when the front-panel ON/STANDBY switch is pressed ON. If the green light beside the ON label fails to light then check the following:

1. That the PRINCIPAL POWER SWITCH located on the back panel is in the ON position.
2. That the line cord is connected to a functional power source with the same output voltage set as the Line Voltage Selector on the back panel.
3. That the fuse is good. If the fuse is blown, replace it. Then check the Power Supply as described after step 4.
4. That the fan is exhausting air from the instrument when the ON/STANDBY switch is ON. A defective fan causes an over-temperature shutdown in the Power Supply.

If these checks fail to correct the problem connect the 067-1264-00 Extended Diagnostics Power Supplies Test Fixture (described more completely in Table 2-1) and refer to its accompanying documentation. The Test Fixture shows which power supply voltage source is having a problem. To help isolate the source of the problem disconnect the power connection to the board using the defective source. Then, power up again. This procedure is only effective for externally shorted Power Supplies. Once again, refer to documentation accompanying the Test Fixture for more troubleshooting hints.

## Regulator Board

This board is implicitly verified; that is, if all the other FRUs pass diagnostic testing, then you can assume that the Regulator board is operating correctly as well.

# Fuse Troubleshooting

If suspect, the following mainframe fuses should be checked:

- F99 the principal line fuse, located on the rear panel (refer to Fig. 3-32)
- F560 the high voltage fuse located on the A13 Scope Logic board (refer to Fig. 3-30)

To check any fuse, remove the power cord from the instrument (+ 16 HK and line voltages are present if the power cord is attached).

Locate the suspect fuse and check that fuse for continuity and proper rating. If a fuse is open, then replace that fuse with a new one of the proper rating.

Isolate the malfunction that is causing the fuse to blow and repair this area.

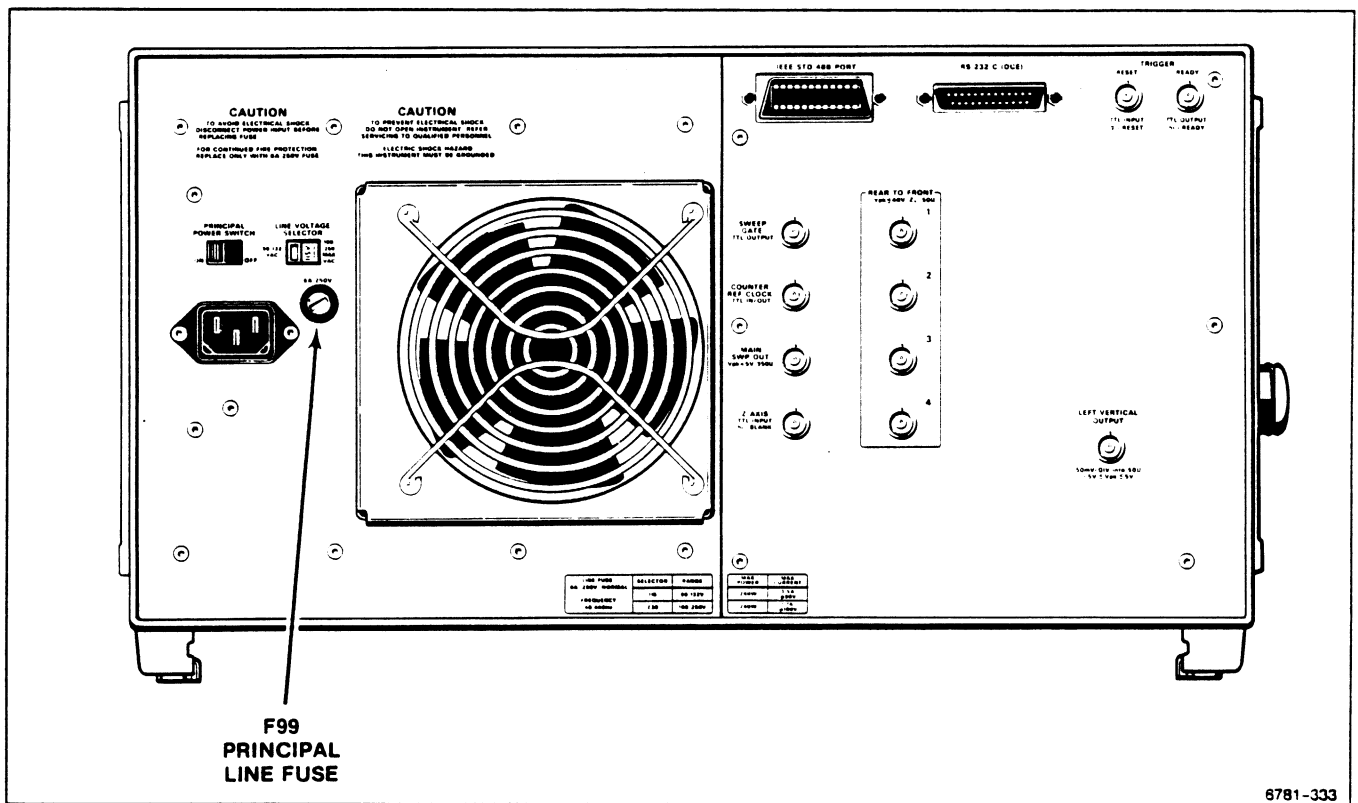

Figure 3-32. Rear panel principal line fuse location.



# Section 4

## Theory of Operation

---

This section describes and illustrates (refer to Fig. 4-1) the 11301 system block diagram.

### Block Diagram Description

The following information provides descriptions of each FRU block shown in Figure 4-1.

#### **A1 Plug-in Amplifier Interface Board**

The obvious purpose of the A1 plug-in amplifier Interface board is to interface plug-in amplifiers to the mainframe. One of the functions of the A1 plug-in amplifier Interface board is to route signals and voltages within the instrument. Another function of this board is to bus power supply voltages from the Power Supply assembly that plugs into the back of the A1 plug-in amplifier Interface board. There are no active components located on this board.

#### **A5, A8, and A9 Front Panel Assembly**

The Front Panel Assembly allows the user to interface with the instrument using the front-panel buttons it supports. The Front Panel Assembly includes the A5 Top Front Panel board, the A8 Center Front Panel board, the A9 Bottom Front Panel board, the buttons, the knobs, the panel, and the sustaining hardware. Each of the three boards has a front-panel light emitting diode (LED) display and the front-panel button inputs. The A9 Bottom Front Panel board also has the vertical and horizontal knobs. No other circuitry exists on these three boards.

#### **A7 Touch Panel Board**

The A7 Touch Panel board has three instrument functions: the Graticule Illumination, the Graticule Detector, and the Touch Sensing Array. The circuitry on the A13 Scope Logic board drives the Graticule Illumination light bulbs. The Graticule Detector consists of four photo transistors that are located at the corners of the crt. These transistors provide the signal input necessary for the circuitry located on the A10 Front Panel Interface board to detect a trace crossing of a graticule on the crt face. The A7 Touch Panel board consists of a ten by fourteen array of infrared LEDs and photo transistors that the circuitry on the A10 Front Panel Interface board and A11 Main Processor board scan. The instrument senses broken (blocked) light beams between an LED and photo transistor pair to detect the menu location that you touched. Specifically, when two beams are broken, one in the X axis and one in the Y axis, the instrument assumes that the intersection of these two broken beams is the location you touched.

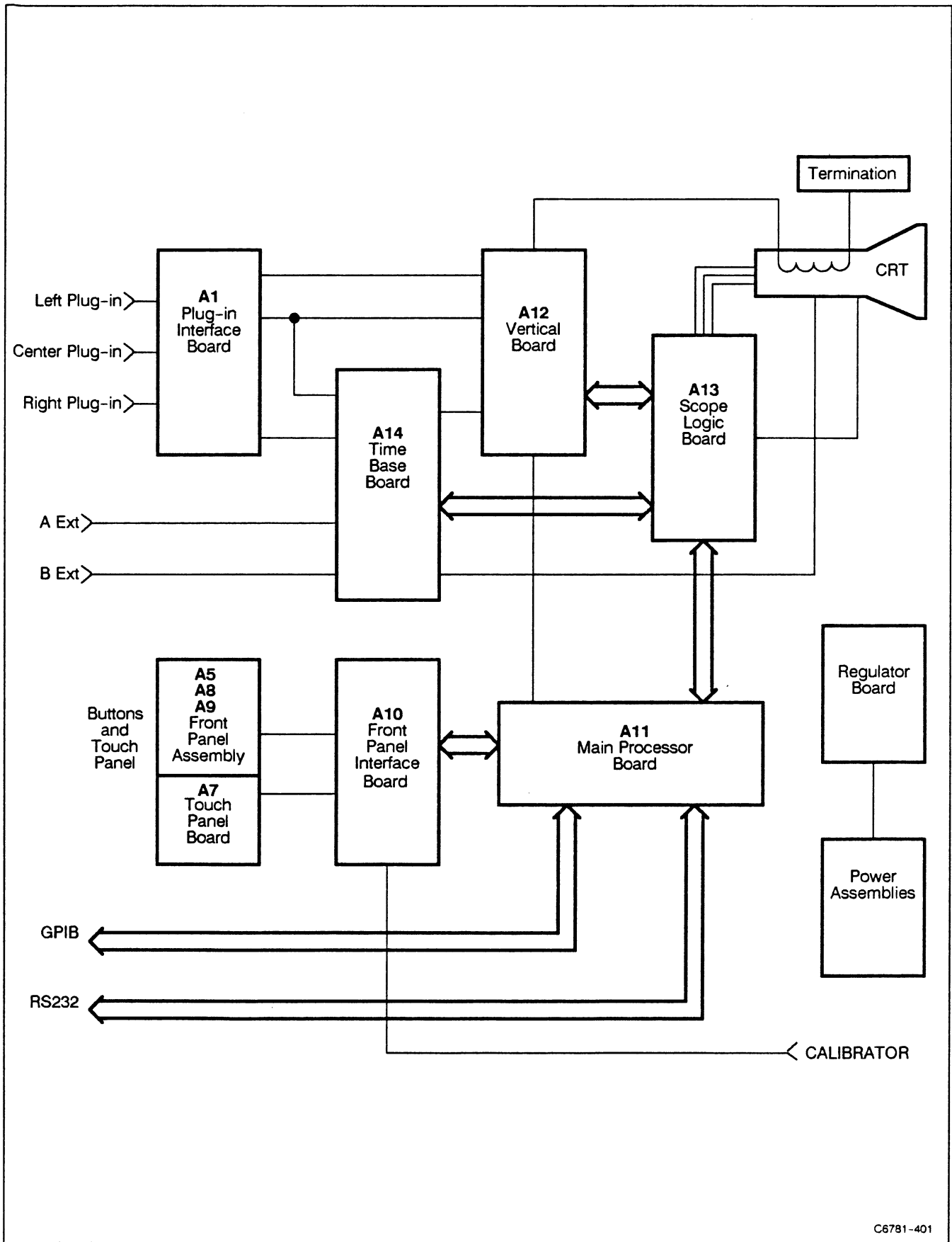

C6781-401

Figure 4-1. 11301 System Block Diagram.

## A10 Front Panel Interface Board

The A10 Front Panel Interface board contains:

- The interfacing circuitry for the A7 Touch Panel board's buttons, knobs, and LEDs.
- The camera reset is a single sweep reset from the camera that facilitates the photographing of waveforms.
- The front-panel calibrator conditions the voltage from the calibration voltage reference (CVR) located on the A13 Scope Logic board and then sends the voltage to the front-panel BNC connector.
- The beam detection circuit locates graticules lines on the CRT so that calibration can align the instrument with the CRT faceplate.

## A11 Main Processor Board

The A11 Main Processor board has several functions:

- The microprocessor kernel and its read only memory (ROM), random access memory (RAM), and non-volatile RAM (NV RAM).
- The RS-232 and GPIB external interfaces provide communication with external instrument controllers.
- The text and stored waveform controller that formats and displays text and stored waveforms. This display activity time shares the CRT with normal waveform displays.
- The Serial Data Interface Controller for processor communications with the plug-in amplifiers and other boards within the mainframe.
- Front-panel control circuitry for scanning the knob and A7 Touch Panel board inputs.
- An analog-to-digital (A to D) converter reads the diagnostic and calibration voltages for the entire instrument.
- The clock and calendar.

The following additional field replaceable units (FRUs) are located on the A11 Main Processor board:

- Firmware (PROMS) – the eight PROMS contain all the instrument's software.
- EEROM IC – the constants for the last factory calibration cycle are stored in the EEROM. The diagnostic system verifies the factory calibration constants using a checksum that is stored with the factory constants. If the EEROM data gets corrupted the instrument may be unusable until recalibrated. Any measurements made using the instrument prior to full calibration may be inaccurate.
- Serial Data Interface Integrated Circuit (IC) – This device has the following functions:

The Front Panel Assembly knob control interfaces with the Front Panel Assembly knob outputs.

The A7 Touch Panel board control interfaces with the Front-Panel Assembly and scans the A7 Touch Panel board for broken beams.

The plug-in amplifier Serial Data Interface controls all the mainframe communication with each of the three plug-in amplifier slots of the mainframe.

The External interfaces control the A11 Main Processor board's control communication with other boards within the mainframe.

- Display Control IC – the display controller and its RAM and digital-to-analog (D to A) converter output circuitry generate all the text readout and stored reference waveforms for display on the crt. Most of the additional circuitry in the mainframe must also function correctly for the readout to actually appear on the crt.
- Battery – a battery maintains the NV RAM during power-down. The instrument could function with a bad (dead) battery, although power-down settings will always be lost and Enhanced Accuracy would not bridge a power-down. The diagnostics are designed to generate a battery error prior to any random memory losses.

## **A12 Vertical Amp Board**

The A12 Vertical Amp board has two functions: the vertical display of signals and the vertical display of readouts. Circuitry located on this board connects one of its many input signals to the output for display on the crt. The A13 Scope Logic board contains the logic that selects which input is displayed at a given time. Input signals to the A12 Vertical Amp board come from the following locations within the instrument:

- Vertical trace information comes from the plug-in amplifiers through the A1 plug-in amplifier Interface board.
- Vertical readout information comes from the A11 Main Processor board. The Display Control IC and the supporting analog signal conditioning circuits located on the A11 Main Processor board generate this signal.
- Counter view information comes from the A14 Time Base board. The counter timer circuit located on the A14 Time Base board generates this signal.
- Calibration reference voltage comes from the A13 Scope Logic board. The calibration reference system located on the A13 Scope Logic board generates this signal. Both the calibration and diagnostic systems on the A12 Vertical Amp board use this voltage.

The A12 Vertical Amp board provides the following signals to the other areas of the instrument:

- The Center plug-in amplifier output is buffered and sent to the A14 Time Base board for the XY trace display.
- The vertical signal output on the rear panel comes from the A12 Vertical Amp board.

The Crt Termination FRU is also coupled with the A12 Vertical Amplifier board. The Crt Termination resistor supplies the terminating impedance for the vertical crt signal.



## **A13 Scope Logic Board**

The A13 Scope Logic board contains the following:

- The crt support circuitry for Z-axis, Geometry, and Focus functions.
- The high voltage supply for the crt.

Logic to select which signal the A12 Vertical Amp board will display. Refer to A12 Vertical Amp board in this section.

- The calibration voltage reference circuit for the calibration, diagnostics, and front-panel calibrator voltages.
- The analog control voltage system that provides the processor-controllable analog voltages to virtually all the functions of the instrument.

The A13 Scope Logic board contains the following additional FRUs:

- The Real Time Oscilloscope Control (ROCS) IC – The microprocessor, through the serial data interface IC located on the A11 Main Processor board, can program the ROCS IC. The ROCS IC generates the control lines that select a waveform source(s) and time base. Also, the ROCS IC controls the time slicing or sequencing of multiple trace displays.
- The Analog Control Voltage (ACVS) processor – The ACVS processor also interfaces with the microprocessor through the serial data interface IC located on the A11 Main Processor board. The function of the ACVS processor is to continuously update (approximately 30 times per second) the sample-and-hold circuits that form the ACVS.

## **A14 Time Base Board**

The A14 Time Base board contains the circuitry that generates the horizontal portion of a sweep. The ROCS located on the A13 Scope Logic board allows the display of multiple sweeps. Specifically, sequencing several sweep setups through the A13 Time Base board and A12 Vertical Amp board allows the display of multiple sweeps.

The A14 Time Base board contains the following:

- The main and delayed triggers.
- The main and delayed sweep time bases.
- The counter timer for making time measurements with the sweeps and triggers.

## **A15 Counter Timer Reference Board (available in Option 1T only)**

The Counter Timer Reference board is another FRU that is located inside of the CRT compartment near the rear of the instrument. This board contains a temperature-controlled, high-stability oscillator and its associated circuitry.



# REPLACEABLE PARTS

## PARTS ORDERING INFORMATION

Replacement parts are available from or through your local Tektronix, Inc. Field Office or representative.

Changes to Tektronix instruments are sometimes made to accommodate improved components as they become available, and to give you the benefit of the latest circuit improvements developed in our engineering department. It is therefore important, when ordering parts, to include the following information in your order: Part number, instrument type or number, serial number, and modification number if applicable.

If a part you have ordered has been replaced with a new or improved part, your local Tektronix, Inc. Field Office or representative will contact you concerning any change in part number.

Change information, if any, is located at the rear of this manual.

## ITEM NAME

In the Parts List, an Item Name is separated from the description by a colon (:). Because of space limitations, an Item Name may sometimes appear as incomplete. For further Item Name identification, the U.S. Federal Cataloging Handbook H6-1 can be utilized where possible.

## FIGURE AND INDEX NUMBERS

Items in this section are referenced by figure and index numbers to the illustrations.

## INDENTATION SYSTEM

This mechanical parts list is indented to indicate item relationships. Following is an example of the indentation system used in the description column.

```

1 2 3 4 5           Name & Description
Assembly and/or Component
Attaching parts for Assembly and/or Component
      **** END ATTACHING PARTS ****
Detail Part of Assembly and/or Component
Attaching parts for Detail Part
      **** END ATTACHING PARTS ****
Parts of Detail Part
Attaching parts for Parts of Detail Part
      **** END ATTACHING PARTS ****

```

Attaching Parts always appear in the same indentation as the item it mounts, while the detail parts are indented to the right. Indented items are part of, and included with, the next higher indentation. The separation symbol - - - \* - - - indicates the end of attaching parts.

## ABBREVIATIONS

#	INCH NUMBER SIZE	ELCTRN	ELECTRON	IN	INCH	SE	SINGLE END
ACTR	ACTUATOR	ELEC	ELECTRICAL	INCAND	INCANDESCENT	SECT	SECTION
ADPTR	ADAPTER	ELCTLT	ELECTROLYTIC	INSUL	INSULATOR	SEMICOND	SEMICONDUCTOR
ALIGN	ALIGNMENT	ELEM	ELEMENT	INTL	INTERNAL	SHLD	SHIELD
AL	ALUMINUM	EPL	ELECTRICAL PARTS LIST	LPHLDR	LAMPHOLDER	SHLDR	SHOULDERED
ASSEM	ASSEMBLED	EQPT	EQUIPMENT	MACH	MACHINE	SKT	SOCKET
ASSY	ASSEMBLY	EXT	EXTERNAL	MECH	MECHANICAL	SL	SLIDE
ATTEN	ATTENUATOR	FIL	FILLISTER HEAD	MTG	MOUNTING	SLFLKG	SELF-LOCKING
AWG	AMERICAN WIRE GAGE	FLEX	FLEXIBLE	NIP	NIPPLE	SLVG	SLEEVING
BD	BOARD	FLH	FLAT HEAD	NON WIRE	NOT WIRE WOUND	SPR	SPRING
BRKT	BRACKET	FLTR	FILTER	OBD	ORDER BY DESCRIPTION	SQ	SQUARE
BRS	BRASS	FR	FRAME or FRONT	OD	OUTSIDE DIAMETER	SST	STAINLESS STEEL
BRZ	BRONZE	FSTNR	FASTENER	OVH	OVAL HEAD	STL	STEEL
BSHG	BUSHING	FT	FOOT	PH BRZ	PHOSPHOR BRONZE	SW	SWITCH
CAB	CABINET	FXD	FIXED	PL	PLAIN or PLATE	T	TUBE
CAP	CAPACITOR	GSKT	GASKET	PLSTC	PLASTIC	TERM	TERMINAL
CER	CERAMIC	HDL	HANDLE	PN	PART NUMBER	THD	THREAD
CHAS	CHASSIS	HEX	HEXAGON	PNH	PAN HEAD	THK	THICK
CKT	CIRCUIT	HEX HD	HEXAGONAL HEAD	PWR	POWER	TNSN	TENSION
COMP	COMPOSITION	HEX SOC	HEXAGONAL SOCKET	RCPT	RECEPTACLE	TPG	TAPPING
CONN	CONNECTOR	HLCPS	HELICAL COMPRESSION	RES	RESISTOR	TRH	TRUSS HEAD
COV	COVER	HLEXT	HELICAL EXTENSION	RGD	RIGID	V	VOLTAGE
CPLG	COUPLING	HV	HIGH VOLTAGE	RLF	RELIEF	VAR	VARIABLE
CRT	CATHODE RAY TUBE	IC	INTEGRATED CIRCUIT	RTNR	RETAINER	W	WITH
DEG	DEGREE	ID	INSIDE DIAMETER	SCH	SOCKET HEAD	WSHR	WASHER
DWR	DRAWER	IDNT	IDENTIFICATION	SCOPE	OSCILLOSCOPE	XFMR	TRANSFORMER
		IMPLR	IMPELLER	SCR	SCREW	XSTR	TRANSISTOR

**CROSS INDEX - MFR. CODE NUMBER TO MANUFACTURER**

<b>Mfr. Code</b>	<b>Manufacturer</b>	<b>Address</b>	<b>City, State, Zip Code</b>
01536	TEXTRON INC CAMCAR DIV SEMS PRODUCTS UNIT	1818 CHRISTINA ST	ROCKFORD IL 61108
04348	LAWRENCE ENGINEERING AND SUPPLY INC	500 S FLOWER ST P O BOX 30	BURBANK CA 91503
06383	PANDUIT CORP	17301 RIDGELAND	TINLEY PARK IL 07094-2917
06665	PRECISION MONOLITHICS INC SUB OF BOURNS INC	1500 SPACE PARK DR	SANTA CLARA CA 95050
06915	RICHCO PLASTIC CO	5825 N TRIPP AVE	CHICAGO IL 60646-6013
07416	NELSON NAME PLATE CO	3191 CASITAS	LOS ANGELES CA 90039-2410
11897	PLASTIGLIDE MFG CORP	2701 W EL SEGUNDO BLVD	HAWTHORNE CA 90250-3318
12327	FREEWAY CORP	9301 ALLEN DR	CLEVELAND OH 44125-4632
16428	COOPER BELDEN ELECTRONIC WIRE AND CA SUB OF COOPER INDUSTRIES INC	NW N ST	RICHMOND IN 47374
18677	SCANBE MFG CO DIV OF ZERO CORP	3445 FLETCHER AVE	EL MONTE CA 91731
28520	HEYCO MOLDED PRODUCTS	750 BOULEVARD P O BOX 160 3M CENTER	KENILWORTH NJ 07033-1721
53387	MINNESOTA MINING AND MFG CO ELECTRONIC PRODUCTS DIV		ST PAUL MN 55101-1428
70903	COOPER BELDEN ELECTRONICS WIRE AND C SUB OF COOPER INDUSTRIES INC	2000 S BATAVIA AVE	GENEVA IL 60134-3325
71400	BUSSMANN DIV OF COOPER INDUSTRIES INC	114 OLD STATE RD PO BOX 14460	ST LOUIS MO 63178
73743	FISCHER SPECIAL MFG CO	111 INDUSTRIAL RD	COLD SPRING KY 41076-9749
77542	RAYOVAC CORP	601 RAYOVAC DR PO BOX 4960	MADISON WI 53711-0960
77900	SHAKEPROOF DIV OF ILLINOIS TOOL WORKS	SAINT CHARLES RD	ELGIN IL 60120
78189	ILLINOIS TOOL WORKS INC SHAKEPROOF DIV	ST CHARLES ROAD	ELGIN IL 60120
80009	TEKTRONIX INC	14150 SW KARL BRAUN DR PO BOX 500 MS 53-111	BEAVERTON OR 97707-0001
81041	HOWARD INDUSTRIES DIV OF MSL INDUSTRIES INC	1 NORTH DIXIE HWY PO BOX 287	MILFORD IL 60953
83486	ELCO INDUSTRIES INC	1101 SAMUELSON RD	ROCKFORD IL 61101
83553	ASSOCIATED SPRING BARNES GROUP INC	15001 S BROADWAY P O BOX 231	GARDENA CA 90248-1819
93907	TEXTRON INC CAMCAR DIV	600 18TH AVE	ROCKFORD IL 61101
95987	WECKESSER CO INC	4444 WEST IRVING PARK RD	CHICAGO IL 60641
S3109	FELLER	ASA ADOLF AG STOTZWEID CH8810	HORGEN SWITZERLAND
S3629	SCHURTER AG H C/O PANEL COMPONENTS CORP	2015 SECOND STREET	BERKELEY CA 94170
TK0861	H SCHURTER AG DIST PANEL COMPONENTS	2015 SECOND STREET	BERKELEY CA 94170
TK1285	GEROME MFG CO INC	PO BOX 737	NEWBURG OR 97132
TK1319	MORELLIS Q & D PLASTICS	1812 16-TH AVE	FOREST GROVE OR 97116
TK1373	PATELEC-CEM (ITALY)	10156 TORINO	VAICENTALLO 62/45S ITALY
TK1456	PAPST MECHATRONIC CORP	AQUIDNECK INDUSTRIAL PK	NEWPORT RI 02840
TK1546	DTM PRODUCTS INC	4725 NAUTILUS COURT S	BOULDER CO 80301
TK1869	ALPS	100 N CNTRE AVE	ROCKVILLE CENTRE NY 11570
TK2038	MULTICOMP INC	3005 SW 154TH TERRACE #3	BEAVERTON OR 97006

Fig. & Index No.	Tektronix Part No.	Serial/Assembly No.		Qty	12345 Name & Description	Mfr.	
		Effective	Discont			Code	Mfr. Part No.
1-1	348-0875-00			1	FLIPSTAND,CAB.:	80009	348-0875-00
-2	200-3133-00			1	COVER, TOP:	80009	200-3133-00
-3	214-0603-02			4	.PIN ASSY,SECRG:W/SPRING WASHER	80009	214-0603-02
-4	386-1151-00			4	.CLAMP,RIM CLENC:SPG STL CD PL	83553	ORDER BY DESCR
-5	386-0227-00			4	.STOP,CLP,RIM CL:	80009	386-0227-00
-6	200-3134-00			1	COVER,BOTTOM:	80009	200-3134-00
-7	214-0603-02			4	.PIN ASSY,SECRG:W/SPRING WASHER	80009	214-0603-02
-8	386-1151-00			4	.CLAMP,RIM CLENC:SPG STL CD PL	83553	ORDER BY DESCR
-9	386-0227-00			4	.STOP,CLP,RIM CL:	80009	386-0227-00
-10	348-0596-00			4	PAD,CAB.FOOT:0.69 X 0.255 X 0.06,PU	80009	348-0596-00
-11	348-0879-00			4	FOOT,CABINET:BOTTOM,BLUE,POLYCARBONATE (ATTACHING PARTS)	80009	348-0879-00
-12	211-0722-00			4	SCREW,MACHINE:6-32 X 0.25,PNH,STL (END ATTACHING PARTS)	80009	211-0722-00
-13	101-0106-00			2	TRIM,DECORATIVE:LEFT SIDE,FRONT CASTING (ATTACHING PARTS)	80009	101-0106-00
-14	211-0722-00			4	SCREW,MACHINE:6-32 X 0.25,PNH,STL (END ATTACHING PARTS)	80009	211-0722-00
-15	101-0107-00			2	TRIM,DECORATIVE:RIGHT SIDE,FRONT CASTING (ATTACHING PARTS)	80009	101-0107-00
-16	211-0722-00			4	SCREW,MACHINE:6-32 X 0.25,PNH,STL (END ATTACHING PARTS)	80009	211-0722-00
-17	426-2099-00			1	FRAME SECT,CAB.:RIGHT SIDE (ATTACHING PARTS)	80009	426-2099-00
-18	211-0718-00			1	SCREW,MACHINE:6-32 X 0.312,FLH,100 DEG,STL	83486	ORDER BY DESCR
-19	212-0685-00			2	SCREW,MACHINE:10-32 X 0.281,PNH,STL (END ATTACHING PARTS)	93907	ORDER BY DESCR
-20	348-0886-00			4	SHLD GSKT,ELEK:FINGER TYPE,18.310 L	80009	348-0886-00
-21	200-2191-00			2	CAP,RETAINER:PLASTIC	80009	200-2191-00
-22	367-0248-01			1	HANDLE,CARRYING:16.341 L,W/CLIP	80009	367-0248-01
-23	426-2098-00			1	FRAME SECT,CAB.:LEFT SIDE (ATTACHING PARTS)	80009	426-2098-00
-24	211-0718-00			1	SCREW,MACHINE:6-32 X 0.312,FLH,100 DEG,STL	83486	ORDER BY DESCR
-25	212-0685-00			2	SCREW,MACHINE:10-32 X 0.281,PNH,STL (END ATTACHING PARTS)	93907	ORDER BY DESCR



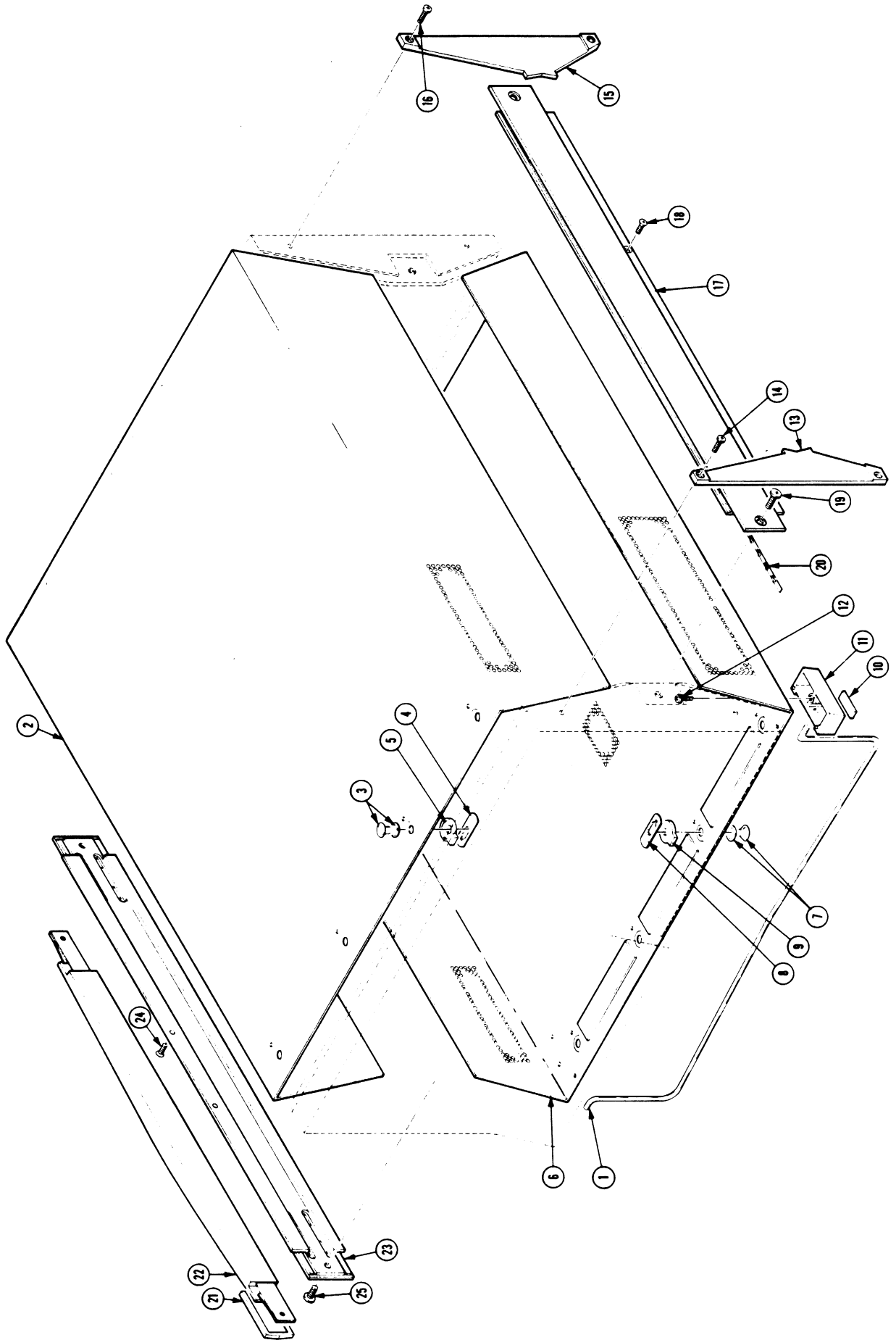

FIG. 1 CABINET  
11301 Service

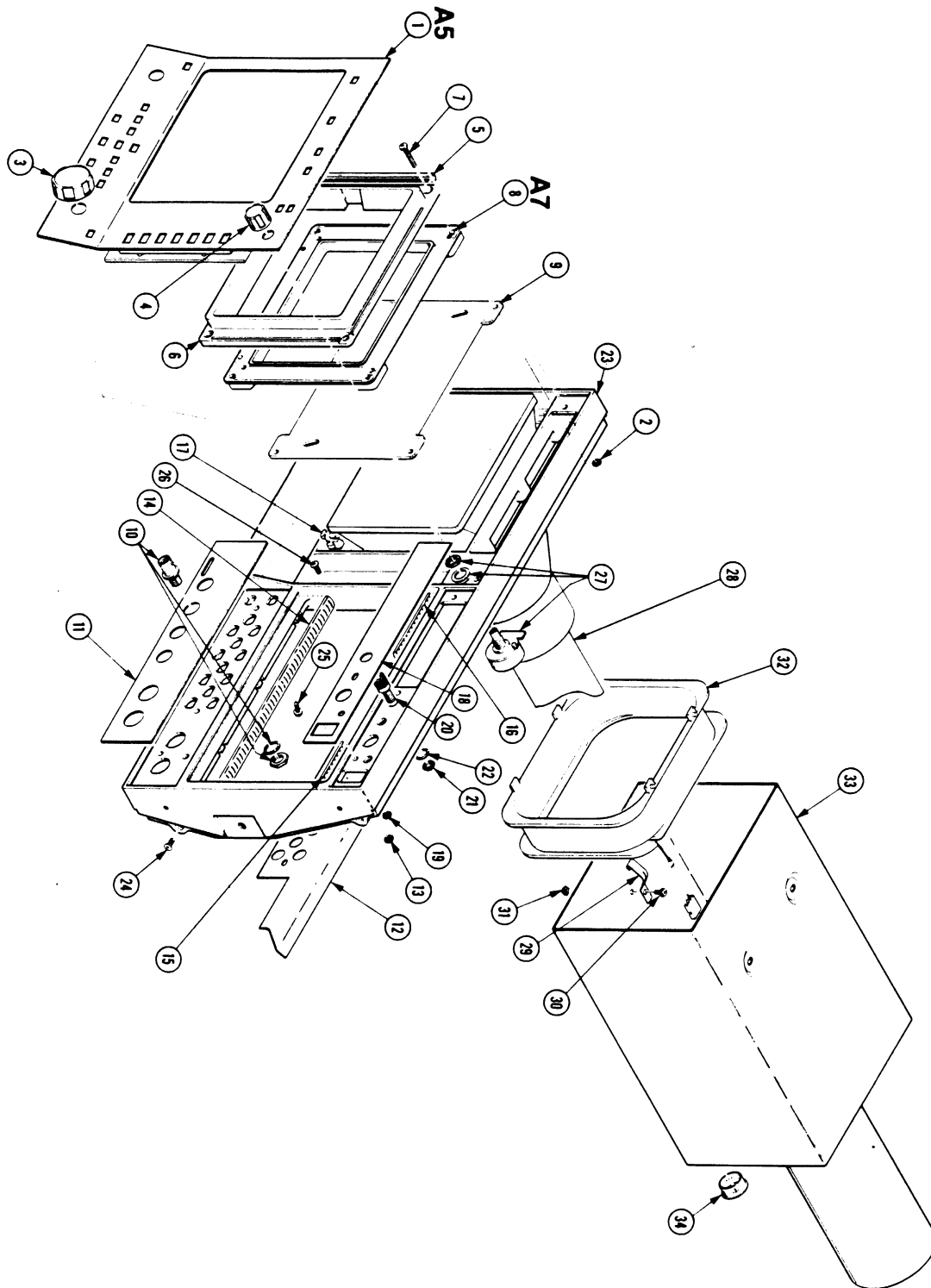

FIG.2 (A) FRONT, CHASSIS, REAR  
11301 Service



Fig. & Index No.	Tektronix Part No.	Serial/Assembly No. Effective	Discnt	Qty	12345 Name & Description	Mfr. Code	Mfr. Part No.
2-1	614-0722-00			1	SUBPANEL ASSY:FRONT (SEE A5) (ATTACHING PARTS)	80009	614-0722-00
-2	210-0586-00			1	NUT, PL, ASSEM WA:4-40 X 0.25, STL CD PL (END ATTACHING PARTS) FRONT PANEL ASSEMBLY INCLUDES:	78189	211-041800-00
-3	366-0582-00			2	.KNOB:ENCODER	TK1546	ORDER BY DESCR
-4	366-0586-01			1	KNOB:ENCODER, GRAY, W/RETAINING RING	80009	366-0586-01
-5	348-0939-00			4	GASKET:EMI, 4.62 X 0.212, SST	80009	348-0939-00
-6	200-3135-02			1	COVER, CRT:SCALE, FINISHED (ATTACHING PARTS)	80009	200-3135-02
-7	211-0752-00			4	SCREW, MACHINE:6-32 X 0.75, PNH, TORX (END ATTACHING PARTS)	80009	211-0752-00
-8	670-8835-00			1	CIRCUIT BD ASSY:TOUCH PANEL (SEE A7)	80009	670-8835-00
-9	337-3281-00			1	SHLD, IMPLOSION:5.97 X 4.78 X 0.062	80009	337-3281-00
-10	131-1315-01			15	CONN, RCPT, ELEC:BNC, FEMALE (FRONT AND BACK)	80009	131-1315-01
	131-1315-01			23	CONN, RCPT, ELEC:BNC, FEMALE (FRONT AND BACK, OPTION 1C ONLY)	80009	131-1315-01
	174-0252-00			1	CABLE ASSY, RF:(4), .50 OHM COAX, 30.5 L W/CONN (FROM FRONT BNC'S TO REAR BNC'S) (OPTION 1C ONLY)	80009	174-0252-00
-11	333-3221-00			1	PANEL, FRONT:LOWER	80009	333-3221-00
	333-3314-00			1	PANEL, FRONT:LOWER, 11302 (OPTION 1C ONLY)	80009	333-3314-00
-12	337-3414-00			1	SHIELD, ELEC:CIRCUIT (ATTACHING PARTS)	80009	337-3414-00
-13	210-0586-00			2	NUT, PL, ASSEM WA:4-40 X 0.25, STL CD PL (END ATTACHING PARTS)	78189	211-041800-00
-14	348-0878-00			1	SHLD GSKT, ELEC:SOLID TYPE, 7.646 L	80009	348-0878-00
-15	348-0877-00			1	SHLD GSKT, ELEC:SOLID TYPE, 1.860 L	80009	348-0877-00
-16	348-0876-00			2	SHLD GSKT, ELEC:SOLID TYPE, 2.480 L	80009	348-0876-00
-17	386-5332-00			4	SUPPORT, CRT:FRONT	80009	386-5332-00
-18	333-3222-00			1	PANEL, FRONT:UPPER (ATTACHING PARTS)	80009	333-3222-00
-19	210-0586-00			3	NUT, PL, ASSEM WA:4-40 X 0.25, STL CD PL (END ATTACHING PARTS)	78189	211-041800-00
-20	129-0103-00			1	POST, BDG, ELEC:ASSEMBLY (ATTACHING PARTS)	80009	129-0103-00
-21	210-0583-00			1	NUT, PLAIN, HEX:0.25-32 X 0.312, BRS CD PL	73743	2X-20319-402
-22	210-0046-00			1	WASHER, LOCK:0.261 ID, INTL, 0.018 THK, STL (END ATTACHING PARTS)	77900	1214-05-00-0541C
-23	386-5275-02			1	SUBPANEL, FRONT:FINISHED (ATTACHING PARTS)	80009	386-5275-02
-24	211-0718-00			4	SCREW, MACHINE:6-32 X 0.312, FLH, 100 DEG, STL	83486	ORDER BY DESCR
-25	211-0409-00			2	SCR, ASSEM WSHR:4-40 X 0.312, PNH, STL	93907	ORDER BY DESCR
-26	211-0718-00			2	SCREW, MACHINE:6-32 X 0.312, FLH, 100 DEG, STL (END ATTACHING PARTS)	83486	ORDER BY DESCR
-27	311-2320-00			1	ENCODER, DIGITAL:INCREMENTAL, 50PPR, 50 DETENT , QUAD OUTPUT, LOC LUG AT 9 O'CLOCK	TK1869	LA22661
-28	154-0883-00			1	CRT ASSEMBLY:FINISHED	80009	154-0883-00
-29	214-1712-00			1	SPRING, FLAT:1.625 X 0.4, CU BE (ATTACHING PARTS)	80009	214-1712-00
-30	211-0408-00			1	SCR, ASSEM WSHR:4-40 X 0.250, PNH, STL TORX	93907	ORDER BY DESCR
-31	210-0586-00			1	NUT, PL, ASSEM WA:4-40 X 0.25, STL CD PL (END ATTACHING PARTS)	78189	211-041800-00
-32	108-1310-00			1	HLD, TERM CONN:TRACE ROTATOR	TK2038	108-1310-00
-33	337-3307-00			1	SHIELD, CRT:	TK1285	ORDER BY DESCR
	334-1379-00			1	MARKER, IDENT:MKD HI VACUUM	07416	ORDER BY DESCR
-34	358-0566-00			4	GROMMET, PLASTIC:BLACK, ROUND, 0.625 ID	28520	2103 (SB 812-10)
-35	351-0744-00			3	GUIDE, PLUG-IN:POLYAMIDE (ATTACHING PARTS)	80009	351-0744-00
-36	211-0722-00			3	SCREW, MACHINE:6-32 X 0.25, PNH, STL (END ATTACHING PARTS)	80009	211-0722-00
-37	200-3295-00			1	COVER, HOLE:CABLE, 4.0 X 3.5 (ATTACHING PARTS)	80009	200-3295-00
-38	211-0722-00			1	SCREW, MACHINE:6-32 X 0.25, PNH, STL	80009	211-0722-00

Fig. & Index No.	Tektronix Part No.	Serial/Assembly No.		Qty	12345 Name & Description	Mfr.	
		Effective	Discort			Code	Mfr. Part No.
2-					(END ATTACHING PARTS)		
-39	358-0166-00			1	GROMMET, PLASTIC: BLACK, U-SHAPE, 0.656 ID	80009	358-0166-00
-40	348-0158-00			1	GROMMET, PLASTIC: BLACK, U-SHAPE, 2.91 ID	TK1319	ORDER BY DESCR
-41	343-1301-00			3	CLAMP, SADDLE: 0.715, NYLON	06915	LWS-2NA
-42	343-1302-00			5	CLAMP, SADDLE: 1.070, NYLON	06915	LWS-3NA
-43	255-0334-00			1	PLASTIC CHANNEL: 12.75 X 0.175 X 0.155, NYLON	11897	122-37-2500
-44	348-0253-00			1	GROMMET, PLASTIC: BLACK, OBLONG, 3.0 X 0.925	80009	348-0253-00
-45	385-0013-00			1	SPACER, POST: 0.75 L W/6-32 THD THRU, NYL	80009	385-0013-00
-46	119-2344-00			1	DELAY LINE, ELEC: 50 OHM COAX ASSY W/COUNTER VIEW & TRIGGER DELAY	80009	119-2344-00
					(ATTACHING PARTS)		
-47	211-0722-00			1	SCREW, MACHINE: 6-32 X 0.25, PNH, STL	80009	211-0722-00
					(END ATTACHING PARTS)		
-48	131-0799-00			4	CONTACT, ELEC: PLUG-IN GND, BE NI CD PL	80009	131-0799-00
					(ATTACHING PARTS)		
-49	211-0408-00			4	SCR, ASSEM WSHR: 4-40 X 0.250, PNH, STL TORX	93907	ORDER BY DESCR
					(END ATTACHING PARTS)		
-50	131-0800-03			2	CONTACT, ELEC: PLUG-IN GND, BE NI HT TR	80009	131-0800-03
					(ATTACHING PARTS)		
-51	211-0408-00			4	SCR, ASSEM WSHR: 4-40 X 0.250, PNH, STL TORX	93907	ORDER BY DESCR
					(END ATTACHING PARTS)		
-52	210-0457-00			1	NUT, PL, ASSEM WA: 6-32 X 0.312, STL CD PL (ATTACHES GROUND WIRE)	78189	511-061800-00
-53	348-0966-00			1	GROMMET, PLASTIC: BLACK, ROUND, 0.625 ID	28520	2872
-54	343-1303-00			1	CLAMP, CABLE: ROUND, 0.437, NYLON (ATTACHING PARTS)	06915	N7B
-55	210-0457-00			1	NUT, PL, ASSEM WA: 6-32 X 0.312, STL CD PL	78189	511-061800-00
-56	210-0863-00			1	WSHR, LOOP CLAMP: 0.187 ID U/W 0.5 W CLP (END ATTACHING PARTS)	95987	C191
-57	358-0215-00			2	GROMMET, PLASTIC: BLACK, U-SHAPED, 0.524 ID	80009	358-0215-00
-58	386-5271-00			1	SPRT, CRT SHIELD: REAR (ATTACHING PARTS)	80009	386-5271-00
-59	211-0722-00			4	SCREW, MACHINE: 6-32 X 0.25, PNH, STL (END ATTACHING PARTS)	80009	211-0722-00
-60	386-5331-00			1	SUPPORT RING: CRT, REAR, POLYCARBONATE (ATTACHING PARTS)	80009	386-5331-00
-61	211-0721-00			4	SCREW, MACHINE: 6-32 X 0.375, PNH, STL	83486	ORDER BY DESCR
-62	210-0949-00			4	WASHER, FLAT: 0.141 ID X 0.5 OD X 0.062, BRS (END ATTACHING PARTS)	12327	ORDER BY DESCR
-63	351-0702-00			1	GUIDE, CKT BOARD: MOLDED NYLON, 4.5 L	18677	11633-22
-64	210-0457-00			1	NUT, PL, ASSEM WA: 6-32 X 0.312, STL CD PL (ATTACHES GROUND WIRE)	78189	511-061800-00
	196-3074-00			1	LEAD, ELECTRICAL: 18 AWG, 12.0 L, 5-4 (FROM REAR PANEL TO CHASSIS)	80009	196-3074-00
-65	333-3224-00			1	PANEL, REAR:	80009	333-3224-00
	333-3315-00			1	PANEL, REAR: (OPTION IC ONLY)	80009	333-3315-00
					(ATTACHING PARTS)		
-66	211-0721-00			6	SCREW, MACHINE: 6-32 X 0.375, PNH, STL (END ATTACHING PARTS)	83486	ORDER BY DESCR
-67	386-5273-02			1	SUBPANEL, REAR: FINISHED (ATTACHING PARTS)	80009	386-5273-02
-68	211-0718-00			8	SCREW, MACHINE: 6-32 X 0.312, FLH, 100 DEG, STL (END ATTACHING PARTS)	83486	ORDER BY DESCR
-69	386-5283-00			2	SUPPORT, CHASSIS: POWER SUPPLY, POLYCARBONATE	80009	386-5283-00
-70	343-0549-00			1	STRAP, TIEDOWN, E: 0.091 W X 4.0 L, ZYTEL	06383	PLT1M
-71	337-3340-00			1	SHIELD, ELEC: CABLE, POLYCARBONATE	80009	337-3340-00
-72	211-0721-00			1	SCREW, MACHINE: 6-32 X 0.375, PNH, STL (ATTACHING PART TO GROUND WIRE)	83486	ORDER BY DESCR
-73	210-0006-00			1	WASHER, LOCK: #6 INTL, 0.018 THK, STL (ATTACHING PART TO GROUND WIRE)	77900	1206-00-00-0541C
-74	610-0752-00			1	CHASSIS ASSY:	80009	610-0752-00

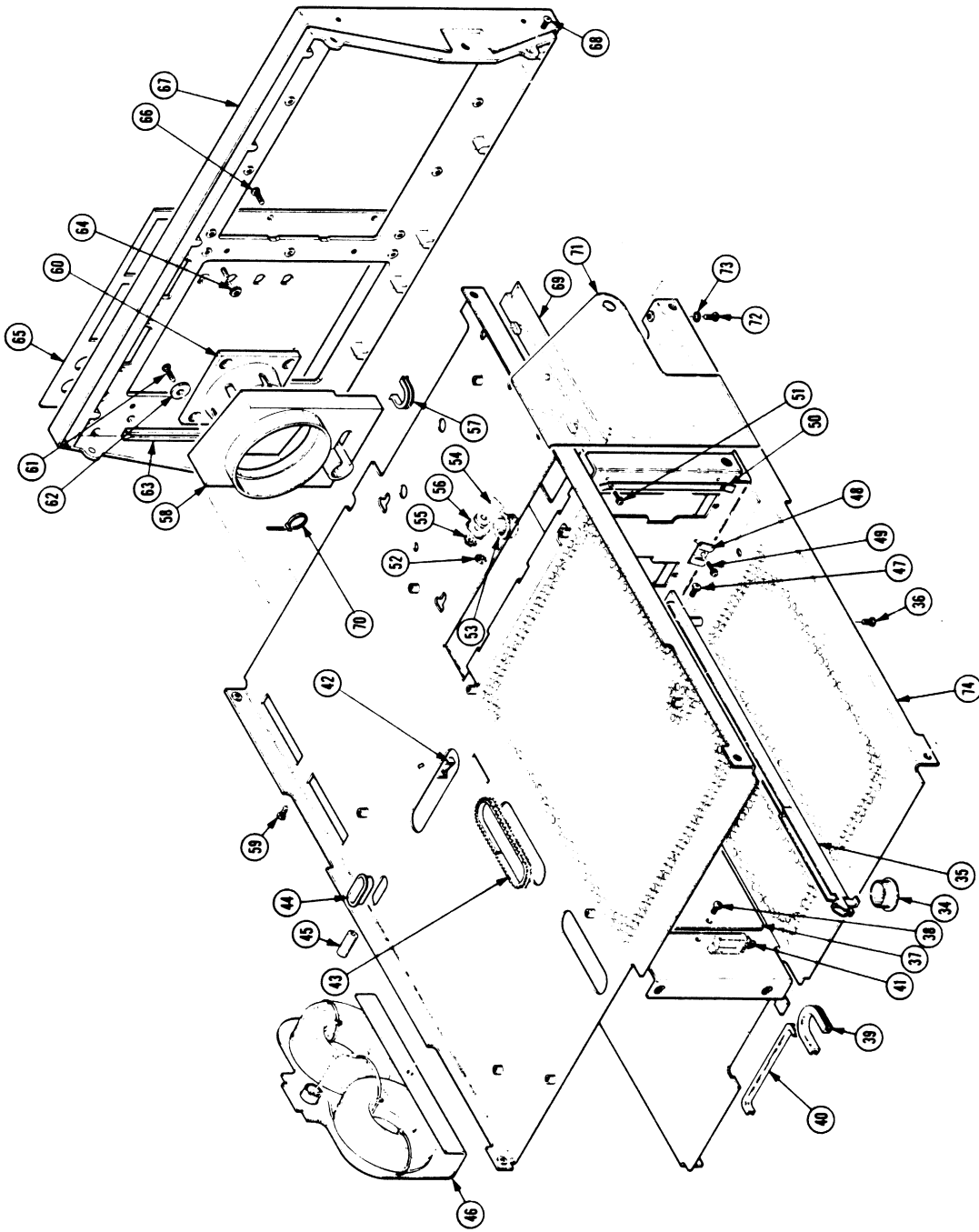

FIG. 2 (B) FRONT, CHASSIS, REAR  
11301 Service

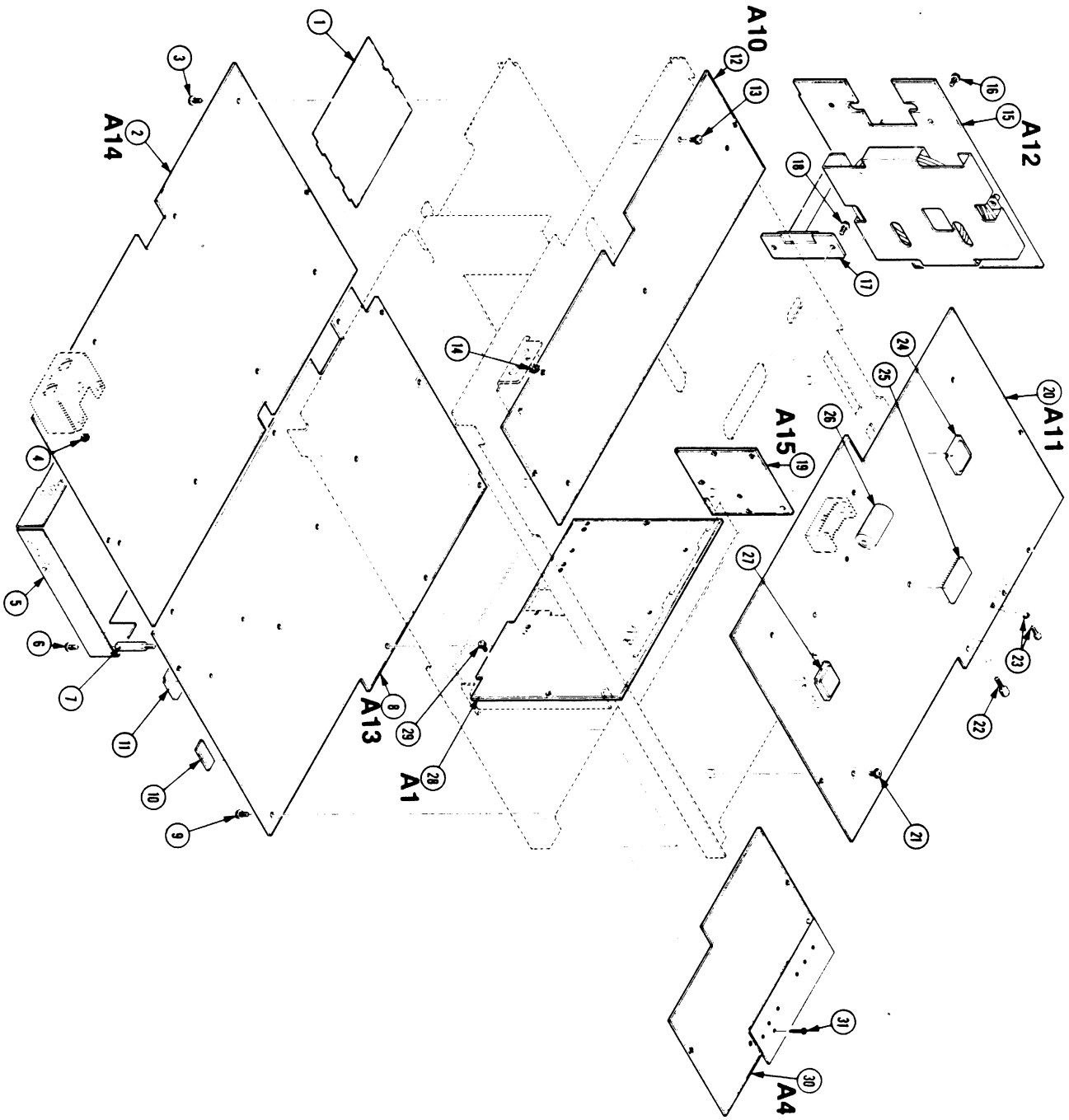

FIG.3 CIRCUIT BOARDS  
11301 Service

Fig. & Index No.	Tektronix Part No.	Serial/Assembly No.		Qty	12345 Name & Description	Mfr.	
		Effective	Discnt			Code	Mfr. Part No.
3-1	337-3341-00			1	SHIELD,ELEC:HV,POLYCARBONATE	80009	337-3341-00
-2	670-8827-00	B010100	B010180	1	CIRCUIT BD ASSY:TIMEBASE	80009	670-8827-00
	670-8827-01	B010181	B010272	1	CIRCUIT BD ASSY:TIME BASE	80009	670-8827-01
	670-8827-03	B010273		1	CIRCUIT BD ASSY:TIME BASE (SEE A14 ) (ATTACHING PARTS)	80009	670-8827-03
-3	211-0711-00			7	SCR,ASSEM WSHR:6-32 X 0.25,PNH,STL,TORX,T15	01536	ORDER BY DESCR
-4	210-0586-00			1	NUT,PL,ASSEM WA:4-40 X 0.25,STL CD PL (END ATTACHING PARTS)	78189	211-041800-00
-5	337-3244-00			1	SHIELD,ELEC:HIGH VOLTAGE (ATTACHING PARTS)	80009	337-3244-00
-6	211-0711-00			4	SCR,ASSEM WSHR:6-32 X 0.25,PNH,STL,TORX,T15 (END ATTACHING PARTS)	01536	ORDER BY DESCR
-7	129-1074-00			4	SPACER,POST:1.350 L,6-32 ONE END,BRS,HEX NI PL	80009	129-1074-00
-8	670-8828-00	B010100	B010271	1	CIRCUIT BD ASSY:SCOPE LOGIC	80009	670-8828-00
	670-8828-01	B010272		1	CIRCUIT BD ASSY:SCOPE LOGIC (SEE A13) (ATTACHING PARTS)	80009	670-8828-01
-9	211-0711-00			7	SCR,ASSEM WSHR:6-32 X 0.25,PNH,STL,TORX,T15 (END ATTACHING PARTS) SCOPE LOGIC BOARD ASSEMBLY INCLUDES:	01536	ORDER BY DESCR
-10	156-1589-00			1	.MICROCKT,LINEAR:D/A CONV,12 BIT HIGH SPEED	06665	DAC312FR
-11	156-2623-00			1	.MICROCKT,DGTL:H MOS,CUSTOM,REALTIME SCOPE	80009	156-2623-00
-12	670-8832-00			1	CIRCUIT BD ASSY:FRONT PANEL INTERFACE (SEE A10) (ATTACHING PARTS)	80009	670-8832-00
-13	211-0711-00			4	SCR,ASSEM WSHR:6-32 X 0.25,PNH,STL,TORX,T15	01536	ORDER BY DESCR
-14	210-0586-00			1	NUT,PL,ASSEM WA:4-40 X 0.25,STL CD PL (END ATTACHING PARTS)	78189	211-041800-00
-15	670-8829-00	B010100	B010273	1	CIRCUIT BD ASSY:VERTICAL	80009	670-8829-00
	670-8829-01	B010274		1	CIRCUIT BD ASSY:VERTICAL (SEE A12) (ATTACHING PARTS)	80009	670-8829-01
-16	211-0711-00			2	SCR,ASSEM WSHR:6-32 X 0.25,PNH,STL,TORX,T15 (END ATTACHING PARTS)	01536	ORDER BY DESCR
-17	307-2091-00			1	RES NTKW,FXD,FI:CRT TERMINATOR(ASSEMBLRD)H2 091 (ATTACHING PARTS)	80009	307-2091-00
-18	211-0711-00			2	SCR,ASSEM WSHR:6-32 X 0.25,PNH,STL,TORX,T15 (END ATTACHING PARTS)	01536	ORDER BY DESCR
-19	670-9124-00			1	CIRCUIT BD ASSY:COUNTER/TIMER REFERENCE (SEE A15,OPTION 1T ONLY)	80009	670-9124-00
-20	670-8831-00	B010100	B010271	1	CIRCUIT BD ASSY:MAIN PROCESSOR	80009	670-8831-00
	670-8831-01	B010272		1	CIRCUIT BD ASSY:MAIN PROCESSOR (SEE A11) (ATTACHING PARTS)	80009	670-8831-01
-21	211-0711-00			5	SCR,ASSEM WSHR:6-32 X 0.25,PNH,STL,TORX,T15	01536	ORDER BY DESCR
-22	129-1003-00			2	SPACER,POST:0.705 L,6-32 EXT/M3.5 X 6-6G INT,BRS,0.25 HEX	80009	129-1003-00
-23	214-3106-00			1	HARDWARE KIT:JACK SOCKET (END ATTACHING PARTS) MAIN PROCESSOR BOARD ASSEMBLY INCLUDES:	53387	3341-1S
-24	156-2624-00			1	.MICROCKT,DGTL:H MOS,SEMI CUSTOM,STANDARD .CELL,DISPLAY CONTROLLER	80009	156-2624-00
-25	156-2192-00			1	.MICROCKT,DGTL:2K X 8,PROM	80009	156-2192-00
-26	146-0050-00			1	.BATTERY,DRY:3V,1200MA,2/3A LITHIUM	77542	BR-2/3A
-27	156-2622-00			1	.MICROCKT,DGTL:H MOS,SEMI CUSTOM,STANDARD .CELL,SERIAL DATA INTERFACE	80009	156-2622-00
-28	670-8830-00			1	CIRCUIT BD ASSY:PLUG-IN INTERFACE (SEE A1) (ATTACHING PARTS)	80009	670-8830-00
-29	211-0408-00			9	SCR,ASSEM WSHR:4-40 X 0.250,PNH,STL TORX (END ATTACHING PARTS)	93907	ORDER BY DESCR
-30	670-8840-00			1	CIRCUIT BD ASSY:REGULATOR (SEE A4) (ATTACHING PARTS)	80009	670-8840-00
-31	211-0721-00			2	SCREW,MACHINE:6-32 X 0.375,PNH,STL	83486	ORDER BY DESCR

Fig. & Index No.	Tektronix Part No.	Serial/Assembly No. Effective    Dscnt	Qty	12345 Name & Description	Mfr. Code	Mfr. Part No.
3-	020-1577-00		1	(END ATTACHING PARTS) MATERIAL KIT:11301 VER 2.4	80009	020-1577-00
				WIRE ASSEMBLIES		
	179-2969-00		1	WIRING HARNESS:MPU,J24/25 (FROM A11J24 TO A14J24) (FROM A11J25 TO A14J25)	80009	179-2969-00
	179-2970-00		1	WIRING HARNESS:TIME BASE,J15,21/23 (FROM A14J21 J22,J23 TO BNC'S) (FROM A14J15 TO A12J15)	80009	179-2970-00

Fig. & Index No.	Tektronix Part No.	Serial/Assembly No. Effective Discart	Qty	12345 Name & Description	Mfr. Code	Mfr. Part No.
4-1	620-0022-00		1	POWER SUPPLY:ET MAINFRAME (ATTACHING PARTS)	80009	620-0022-00
-2	211-0721-00		8	SCREW,MACHINE:6-32 X 0.375,PNH,STL (END ATTACHING PARTS)	83486	ORDER BY DESCR
-3	200-2222-00		1	.GUARD,FAN: (ATTACHING PARTS)	81041	6-182-033
-4	211-0744-00		4	.SCREW,MACHINE:6-32 X 2.0,PNH,TORX,STL,CD (END ATTACHING PARTS)	04348	ORDER BY DESCR
-5	407-3362-00		1	.BRACKET,FAN:0.050 5005 H-34	80009	407-3362-00
-6	200-2264-00		1	.CAP,FUSEHOLDER:3AG FUSES	S3629	FEK 031 1666
-7	159-0013-00		1	.FUSE,CARTRIDGE:3AG,6A,250V,MEDIUM BLOW (FUSE USED IN FUSE HOLDER)	71400	MTH-CW-6
	159-0021-00		1	.FUSE,CARTRIDGE:3AG,2A,250V,FAST BLOW (FUSE USED ON LINE INVERTER BOARD)	71400	AGC-CW-2
-8	204-0832-00		1	.BODY,FUSEHOLDER:3AG & 5 X 20MM FUSES	TK0861	031 1673
-9	119-1725-01		1	.FAN,TUBEAXIAL:8 TO 14.5VDC,6W,3200RPM, .106CFM	TK1456	4112 KX





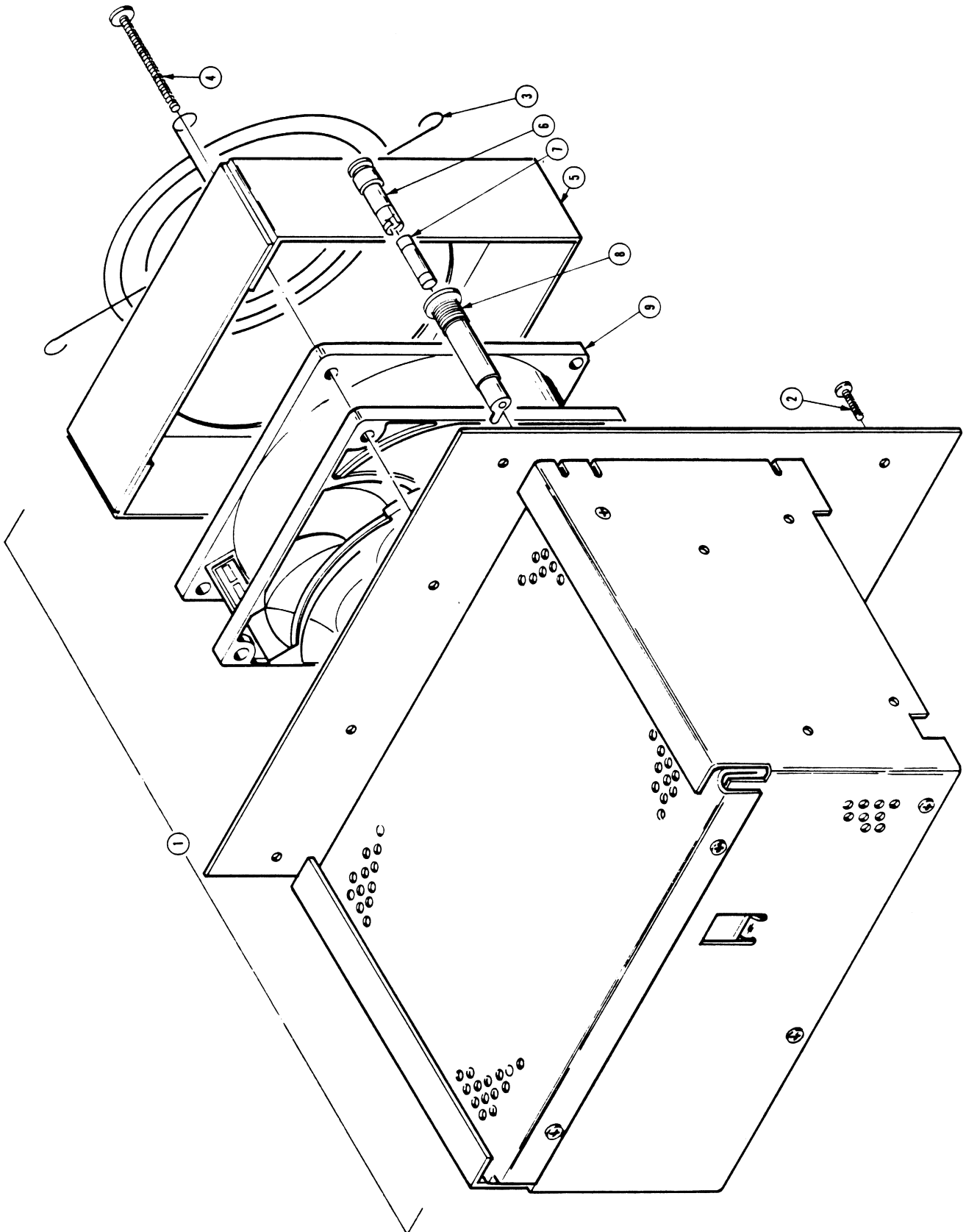

FIG. 4 POWER SUPPLY  
11301 Service

Fig. & Index No.	Tektronix Part No.	Serial/Assembly No.		Qty	12345 Name & Description	Mfr.	
		Effective	Dscont			Code	Mfr. Part No.
5-1	161-0066-00			1	CABLE ASSY,PWR,:3,18AWG,115V,98.0 L	16428	CH8481, FH8481
-2	161-0066-09			1	CABLE ASSY,PWR,:3,0.75MM SQ,220V,99.0 L (OPTION A1 ONLY)	S3109	86511000
-3	161-0066-10			1	CABLE ASSY,PWR,:3,0.75MM SQ,240V,96.0 L (OPTION A2 ONLY)	TK1373	24230
-4	161-0066-11			1	CABLE ASSY,PWR,:3,0.75MM,240V,96.0 L (OPTION A3 ONLY)	S3109	ORDER BY DESCR
-5	161-0066-12			1	CABLE ASSY,PWR,:3,18 AWG,250V,99.0 L (OPTION A4 ONLY)	70903	CH-77893
-6	161-0154-00			1	CABLE ASSY,PWR,:3,0.75MM SQ,240V,6A,2.5M L (OPTION A5 ONLY)	S3109	86515000
	012-0208-00			8	CABLE,INTCON:10.0 L (OPTION 1C ONLY)	80009	012-0208-00
	016-0829-00			1	PANEL,BLANK:PLUG-IN HOUSING,11K SERIES	80009	016-0829-00
	070-6104-00			1	MANUAL,TECH:OPERATORS,11301	80009	070-6104-00
	070-6105-00			1	MANUAL,TECH:OPERATORS,11301	80009	070-6105-00
	070-6106-00			1	MANUAL,TECH:USERS REFERENCE,11301 & 11302	80009	070-6106-00
	070-6274-00			1	MANUAL,TECH:INSTR,11401/11402 (OPTION 1R ONLY)	80009	070-6274-00
	070-6693-00			1	PROCEDURE:INCOMING INSPECTION,11301/2	80009	070-6693-00
					OPTIONAL ACCESSORIES		
	016-0154-00			1	VISOR,CRT:GENERAL USAGE	80009	016-0154-00
	016-0260-00			1	VISOR,CRT:	80009	016-0260-00
	070-6780-00			1	MANUAL,TECH:SERVICE REF,11301	80009	070-6780-00

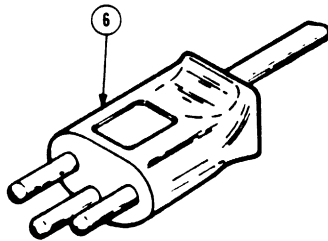
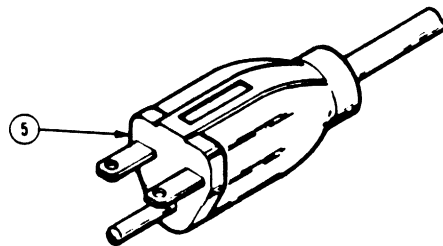
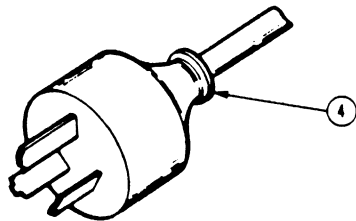
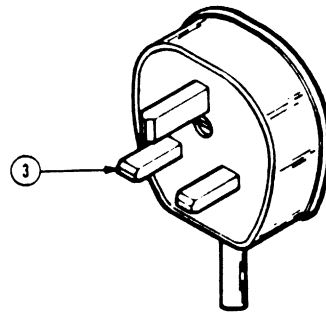
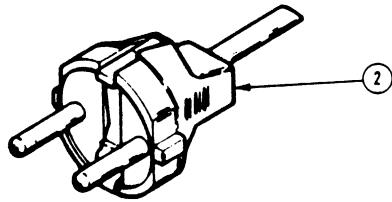
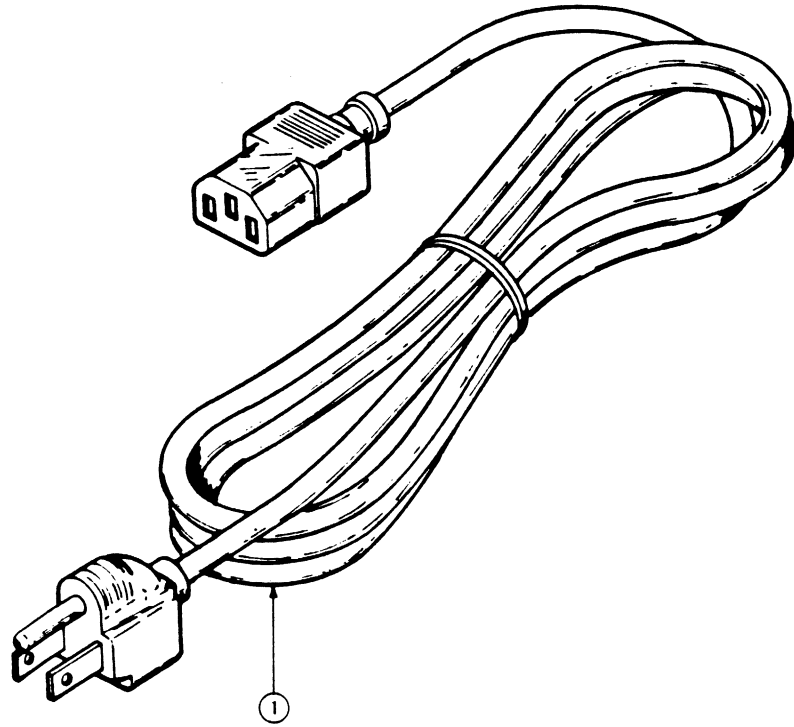

FIG. 5 ACCESSORIES  
11301 Service



## **MANUAL CHANGE INFORMATION**

At Tektronix, we continually strive to keep up with latest electronic developments by adding circuit and component improvements to our instruments as soon as they are developed and tested.

Sometimes, due to printing and shipping requirements, we can't get these changes immediately into printed manuals. Hence, your manual may contain new change information on following pages.

A single change may affect several sections. Since the change information sheets are carried in the manual until all changes are permanently entered, some duplication may occur. If no such change pages appear following this page, your manual is correct as printed.



SEND TO: TEKTRONIX, INC.  
LAB INSTRUMENTS MARKETING SUPPORT  
P.O. BOX 500, DEL STA 39-327  
BEAVERTON, OREGON 97077

# 11000-SERIES OSCILLOSCOPE PROBLEM REPORT

**A INSTRUMENT CONFIGURATION:**

Instrument	Section	ROM (Version)	ID # (Serial Number)

Option Information

COMPANY NAME: \_\_\_\_\_  
USER: \_\_\_\_\_  
**B** ADDRESS: \_\_\_\_\_  
CITY: \_\_\_\_\_ STATE: \_\_\_\_\_ ZIP: \_\_\_\_\_  
PHONE: \_\_\_\_\_ EXTENSION: \_\_\_\_\_

REASON FOR REPORT

- Hardware/Mechanical Problem
- Software/Firmware Problem
- Documentation Problem
- Suggested Enhancement **C**

SUBMITTED BY: \_\_\_\_\_ DATE: \_\_\_\_\_

IS THE PROBLEM REPRODUCIBLE?

- Yes
- No
- Intermittent

**D** SYSTEM DESCRIPTION: (Hardware, software, firmware and host related to the problem)

**E** DESCRIPTION OF PROBLEM:

LIST ENCLOSURES:



# Instructions For Completing The Problem Report

- I. Please type or print clearly. Use a separate Problem Report (PR) for each problem.
- II. **SECTION A**  
Fill in the instrument configuration table, including all plug-in units, modules, and probes installed in the oscilloscope. The information can be found in one of the menus under the UTILITY major menu.  
**Instrument:** Write the instrument name (e.g., 11301, 11401, 11A32, etc.).  
**Section (Microprocessor Subsystem):** If the instrument has more than one section write the section name. For plug-ins, write in which mainframe slot they are located (e.g., left, center, right).  
**ROM (Version):** Write the rom version number for each instrument and section. Instruments with more than one section will have more than one version number.  
**ID# (Serial Number):** Write the serial number for each instrument. At the factory the ID number is programmed to be the instrument's serial number. If this value has been changed, please write the serial number physically attached to the instrument (mainframes: front panel, plug-in units: top rail).
- III. **SECTION B**  
Use the complete company mailing address. Include the name and phone number of the person reporting the error. Also, be sure to fill in the name of the person submitting the PR.
- IV. **SECTION C**  
Check the reason for the report and whether the problem is reproducible. We cannot fix a problem when we cannot reproduce the problem condition.
- V. **SECTION D**  
Give a complete description of the system configuration on which the problem occurred. Include related peripherals, interfaces, options, special switch and/or strap settings and operating system.
- VI. **SECTION E**  
Describe the problem completely. Include any information which might help in evaluating the error with the PR. If you have determined a procedure to avoid the error condition, please include this procedure. If this problem prevents you from accomplishing any useful work with the product, please state this fact. Be sure to include with the PR any information (programs, listings, hard copies, etc.) which will help us duplicate your problem.
- VII. **SECTION F**  
This section is for use by Tektronix Lab Instruments Marketing Support personnel. **DO NOT WRITE IN THIS SPACE.**
- VIII. **Mail all copies of the Problem Report to:**  
TEKTRONIX, INC.  
LAB INSTRUMENTS MARKETING SUPPORT  
P.O. BOX 500, DEL STA 39-327  
BEAVERTON, OREGON 97077

---

INTERNAL USE ONLY  
(DO NOT WRITE BELOW THIS LINE)

---

F

DATE RECEIVED .....
IR # .....